

BECK[®]

INSTRUCTION MANUAL & QUICK CONFIGURATION GUIDE



INTRODUCTION

This manual contains the information needed to install, operate, and maintain Beck Group 88 actuators, manufactured by Harold Beck & Sons, Inc. of Newtown, Pennsylvania.

The Group 88 multiturn actuator is designed to provide precise position control of industrial valves and gates requiring up to 250 lb-ft (339 N•m) of actuator torque.

IMPORTANT: This manual contains information that will make installation simple, efficient, and trouble-free. Please read and understand the appropriate sections in this manual before attempting to install or operate the actuator.



TABLE OF CONTENTS

Introduction	2
General Specifications	4
External Features	5
Outline Dimension Drawings	6
Precautionary Information	8
General Operation Information	9
Installation	11
Mechanical	11
Electrical	12
Wiring	13
Quick Configuration Guide	15
Maintenance	18
Troubleshooting	23
Appendices	27
Bluetooth® App	27
Configuration Menu Tree	28
Index	38
Services	39

GENERAL SPECIFICATIONS

Actuator Power	480 VAC, 3-phase, 50/60 Hz (allowable tolerance +/- 10%).
Current Draw	5A max.
Operating Conditions	-40° to 60°C (-40° to 140°F) 0 to 100% relative humidity, non-condensing
Storage Conditions	-20° to 60°C (-4° to 140°F) 0 to 100% relative humidity, non-condensing
Rated Output (per EN15714)	250 lb-ft (339 N•m); configurable from 10–100%. Optional gearboxes are available for applications requiring greater than 250 lb-ft of torque, stems greater than 2" diameter and quarter turn applications. (Max. thread size cannot exceed a 2 inch nominal thread or 1 3/4 inch keyed shaft).
Velocity	60 RPM; configurable from 10–100%
Configuration Interface	Programmable configuration with menu-driven selections utilizing handswitches and display.
Communication	Bluetooth® wireless technology capable.
Demand Input Signal	4–20 mA (option 9 only), see page 13.
Position Feedback Signal	4–20 mA (option 9 only), see page 13.
Position Status Indication	Alphanumeric LCD position indication and configurable red, green and yellow LED discrete indicating lights.
Action on Loss of Power	Stays in place. Maintains absolute position up to 4,000 revolutions (without batteries) in the event of power failure.
Stall Protection	Powers down the motor if it tries to run in one direction—with no change in position—for more than 5 seconds (configurable from 2 to 300 seconds).
Overtorque Protection	Controlled by motor current ensuring precise overtorque control.
Relays (configurable)	Four configurable, SPST relays are provided, rated at 250 VAC / 30 VDC, 2A max. Each relay may be independently configured for any one of a number of functions. See page 35 for function descriptions and configuration instructions. A future optional relay board provides two additional DPDT relays.
Handswitches (2)	Non-intrusive, magnetic operation.
(REMOTE/LOCAL/STOP)	Permits local electrical operation independent of controller signal. May be locked in any of the three modes.
(OPEN/CLOSE)	For local, manual operation, as well as for setting configuration parameters. May be set to operate in latching or non-latching mode, and may also be enabled or disabled.
Handwheel with manual drive	Provides manual operation without electrical power utilizing a worm pinion. Includes a 1/2" hex to allow a drill with a standard socket to more quickly move the actuator to open or close.
Motor Assembly	Starts at full torque, eliminating the need for "hammer blow". Soft start and stop motor control to reduce wear on drive nut. Does not coast or overshoot and will not overheat—even under continuous modulation.
Gear Train	Unique, all ferrous spur gear design is permanently lubricated.
Enclosure	Precision-machined, aluminum alloy castings coated with corrosion-resistant polyurethane paint, provide rugged, dust-tight, weatherproof enclosures. Type 4X; IP66/IP68, 3 meters/48 hours (internal water damage is not covered by warranty).
Mounting Orientation	Any orientation—no limitations.
Electrical Safety Certification	CSA labeled (US & Canada)

EXTERNAL FEATURES

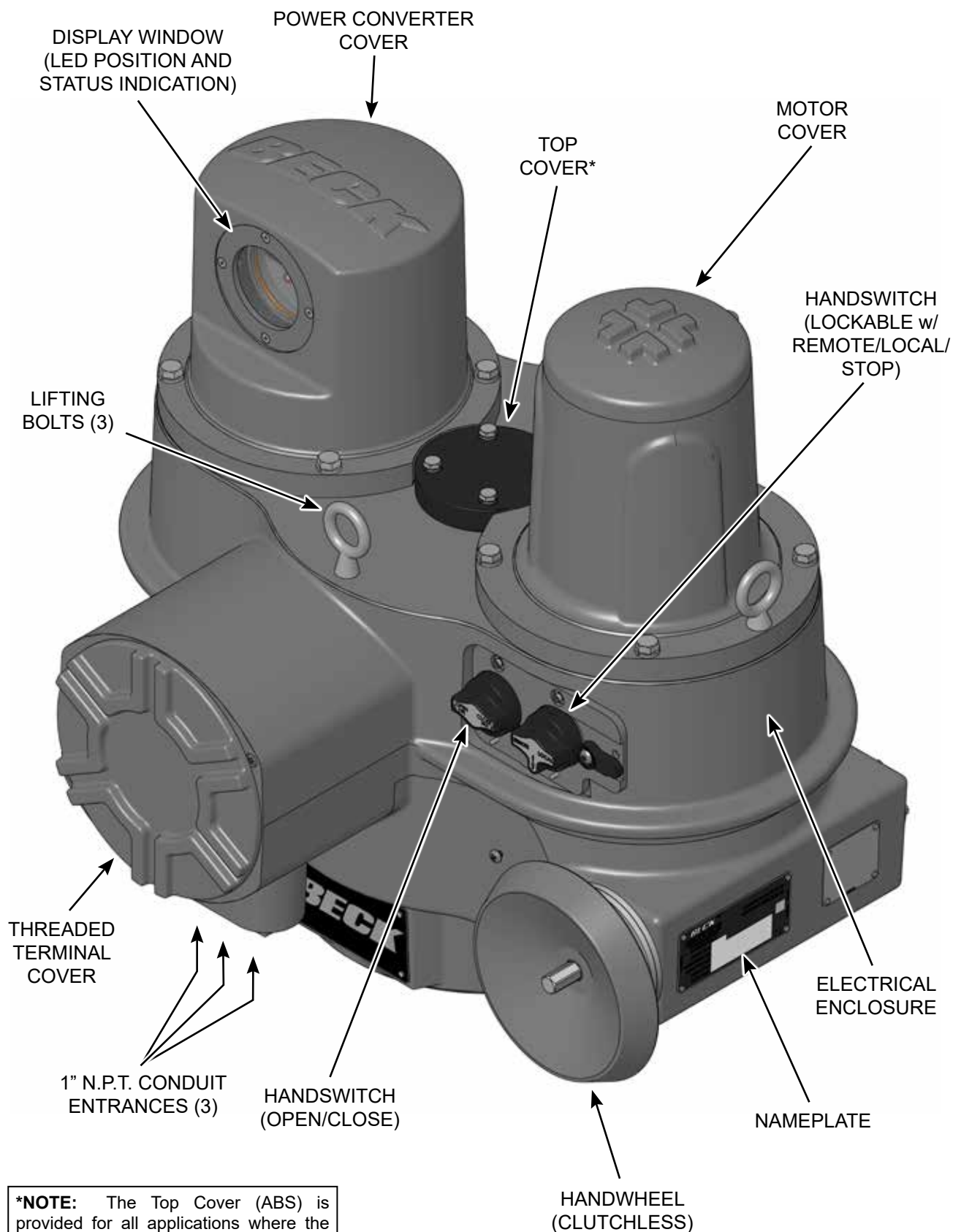

***NOTE:** The Top Cover (ABS) is provided for all applications where the valve stem does not extend through the actuator. All other actuators are shipped with a temporary top cover not intended for permanent use.

NOTE: Images are for reference only.

OUTLINE DIMENSIONS

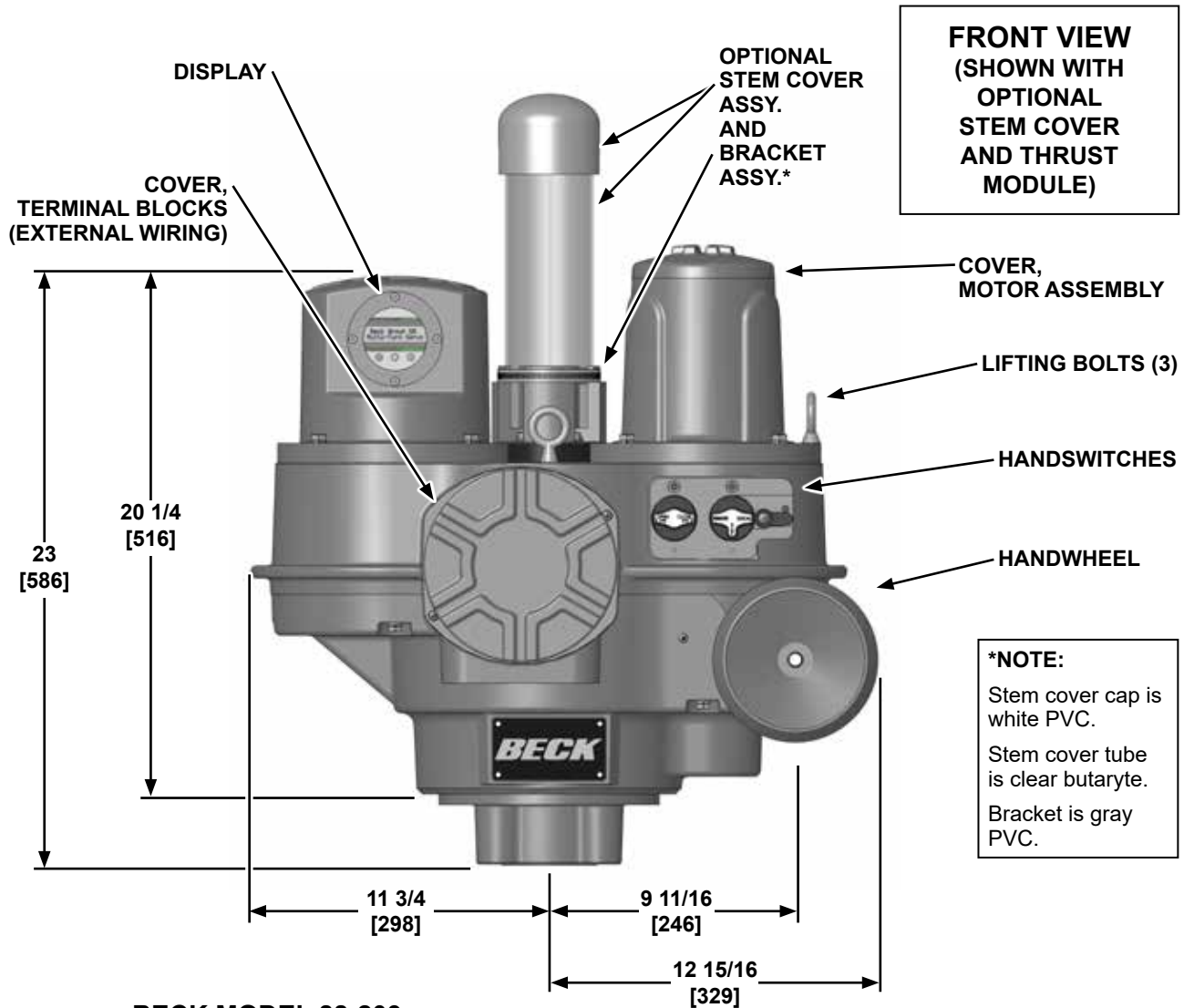

***NOTE:**
 Stem cover cap is white PVC.
 Stem cover tube is clear butaryte.
 Bracket is gray PVC.

BECK MODEL 88-203

Approx. Weight	Rated Torque	Max. Stem Thread Size
180 lbs. 81.6 kgs.	250 lb-ft 339 N·m	2"

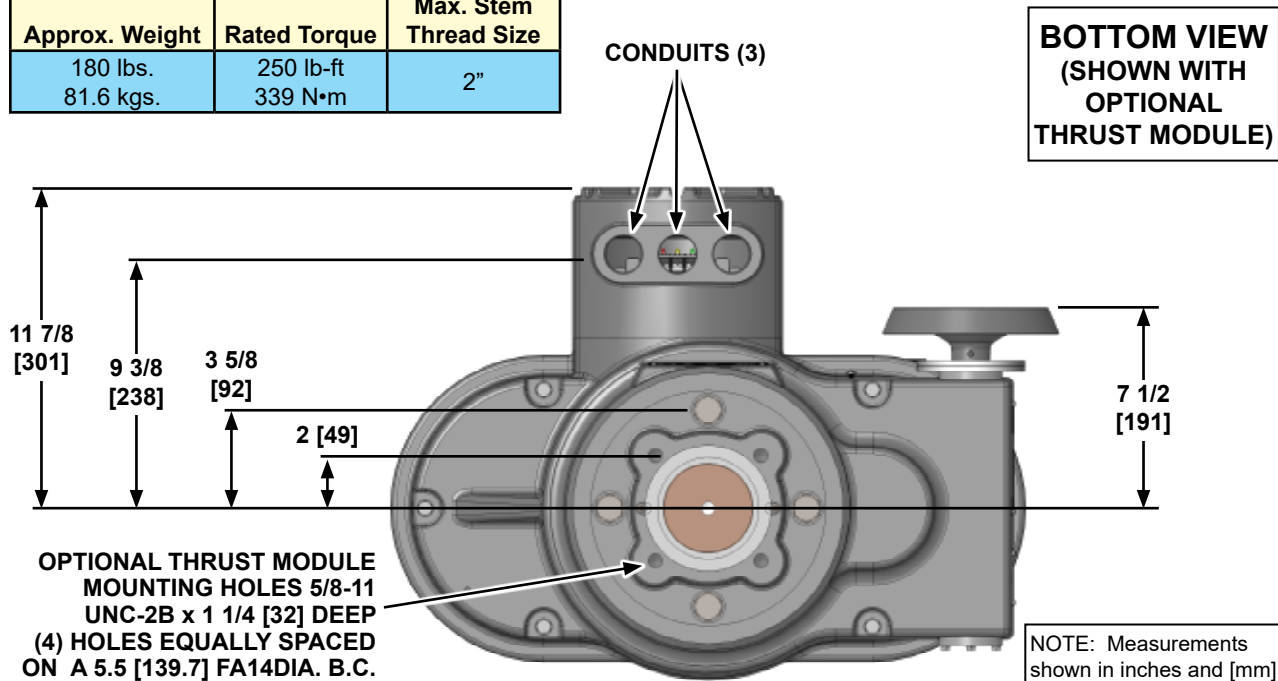

NOTE: Measurements shown in inches and [mm].

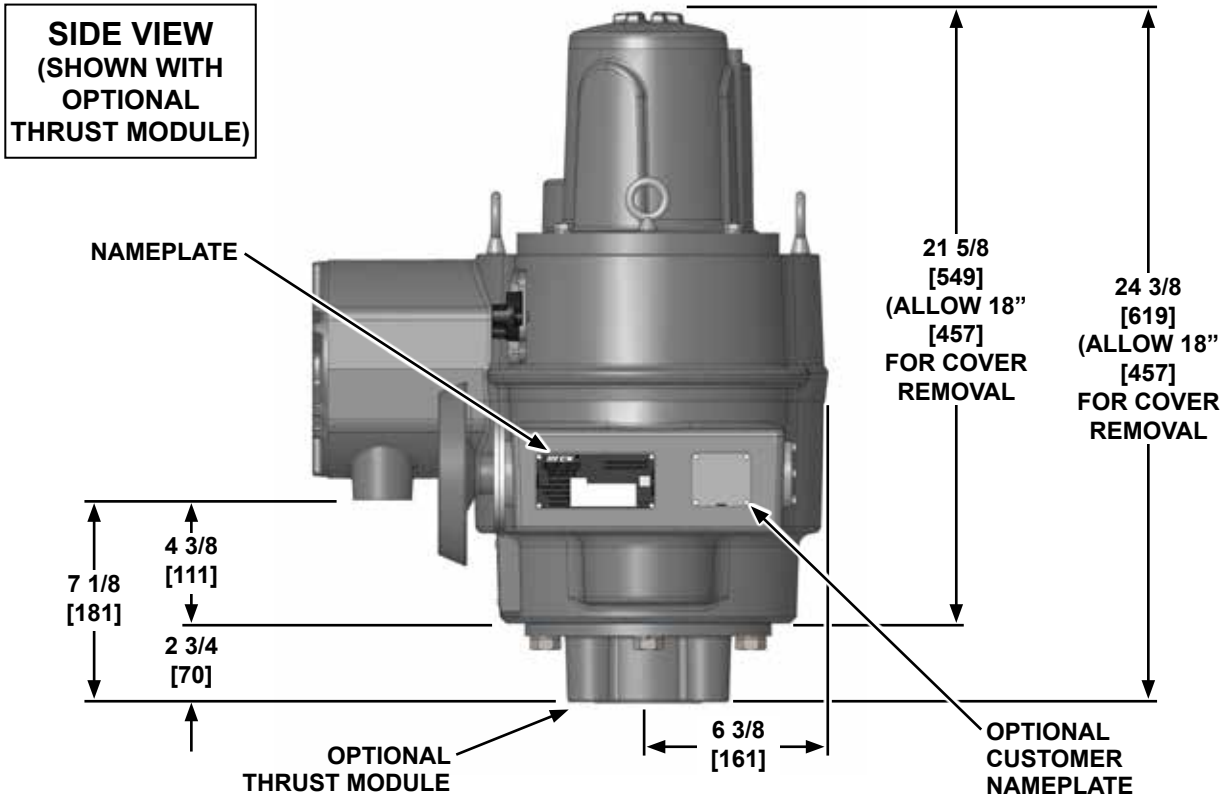

NOTE: Measurements shown in inches and [mm].

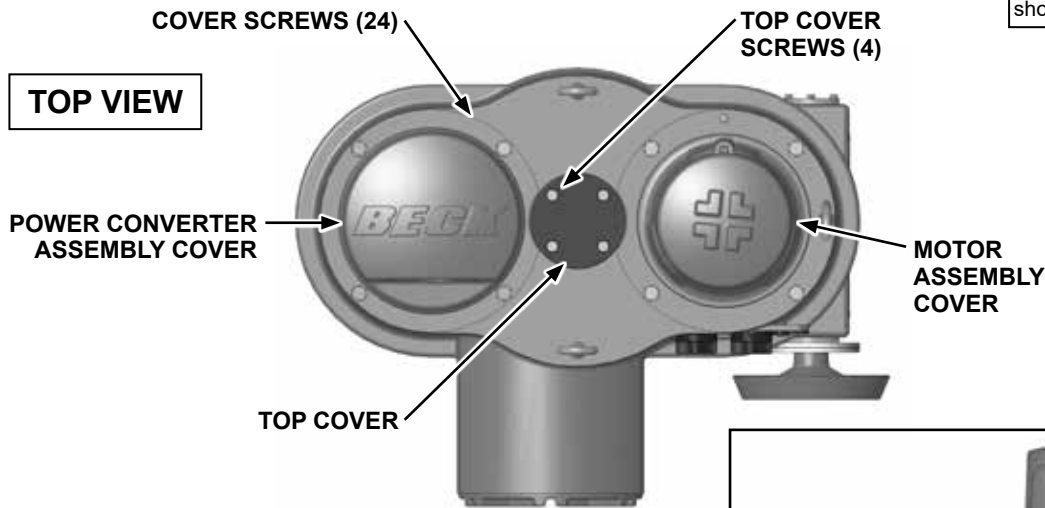

88-203 FASTENER GUIDE

	Size (in.)	Torque lb-ft [N·m]
Top Cover Screws (4)	1/4-20	6 [8]
Cover Screws (24)*	3/8-16	20 [27]
(Optional) Thrust Module Screws (4)	5/8-11	100 [136]

*Quantity may differ depending on application.

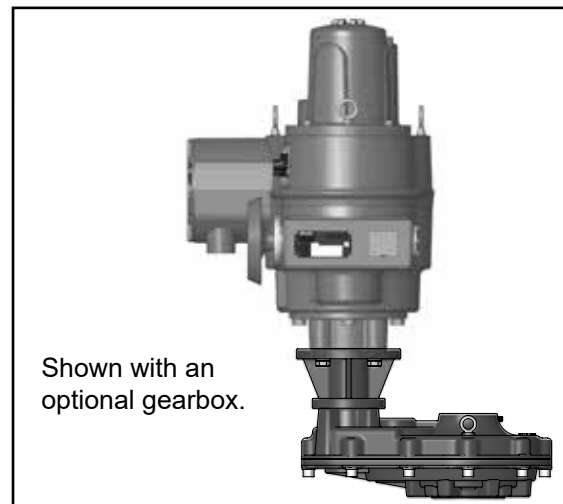

PRECAUTIONARY INFORMATION

SAFETY PRECAUTIONS



WARNING

Installation and service instructions are for use by qualified personnel only. To avoid injury and electric shock, do not perform any servicing other than that contained in this manual. Please read and understand the appropriate sections in this manual before attempting to install or operate the actuator.

STORAGE INFORMATION

Beck actuators should be stored in a clean, dry area where the temperature is between -20° and 60°C (-4° to 140°F).

Damage due to moisture while in storage is not covered by warranty.

INSTALLATION—MECHANICAL

See the following instructions for details. Refer to the outline dimension drawings for physical dimensions and required clearances.

VALVE ACTUATOR INSTALLATIONS



CAUTION

Working with valves installed in a pipeline can be dangerous. Take appropriate precautions when mounting to installed valves.

INSTALLATION—ELECTRICAL

See the following instructions for details regarding electrical installation.



CAUTION

For maximum safety, the Beck actuator body must be grounded. Use the green grounding screw in the wiring compartment of the actuator.



CAUTION

Always close covers immediately after installation or service to prevent moisture or other foreign matter from entering the actuator.



CAUTION

Under certain extreme circumstances, the non-metallic parts incorporated in the enclosure of this equipment may generate an ignition-capable level of electrostatic charge. Therefore the equipment shall not be installed in a location where the external conditions are conducive to the build-up of electrostatic charge on such surfaces. In addition, the equipment shall only be cleaned with a damp cloth.



CAUTION

Conduit entrances are provided for power and signal wiring. Temporary plugs are installed in the conduit entrances at the factory for shipping only and are not intended for permanent use. Prior to actuator operation, all conduit entrances must be properly sealed in accordance with National Standards or Regulatory Authorities.

GENERAL OPERATION INFORMATION

MODES OF OPERATION

There are three basic modes of operation:

- **Handwheel**—local mechanical control
- **Handswitch**—local electrical control
- **Remote**—remote electrical control

Any or all of these modes can be used to test basic operation of the actuator during start-up.

LED STATUS INDICATORS

Three LED indicators are used to provide general position status to the user. The LEDs are located on the front display of the actuator below the LCD character display.

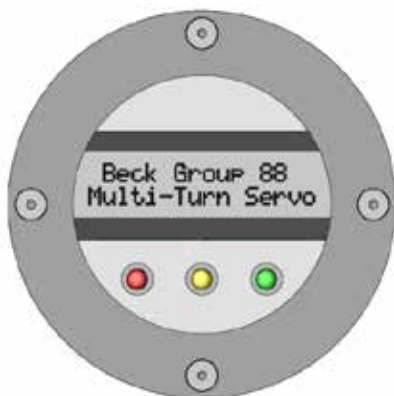

The Red and Green LEDs indicate that the actuator has reached the open or closed position. The position associated with the two LED colors is user configurable through the Close LED setting. However, by default the Green LED indicates a closed condition and the Red LED indicates an open condition. The yellow LED always indicates the actuator is in-between the open and closed positions.

In the event the Open or Close Action has been set to Torque, the Red or Green LED will blink when the Open or Closed position has been achieved, but the torque limit has not been reached. Once the torque limit has been achieved, the LED will no longer blink and remain lit.

HANDWHEEL

The handwheel permits manual operation of the actuator without power and is particularly useful during initial installation or when power is not available. If power is available, the handswitch must be moved to the STOP position before manually operating the handwheel.

Extending through the middle of the handwheel is a 1/2" hex to allow a drill with a standard socket to more quickly move the actuator to the open or close position, if desired.

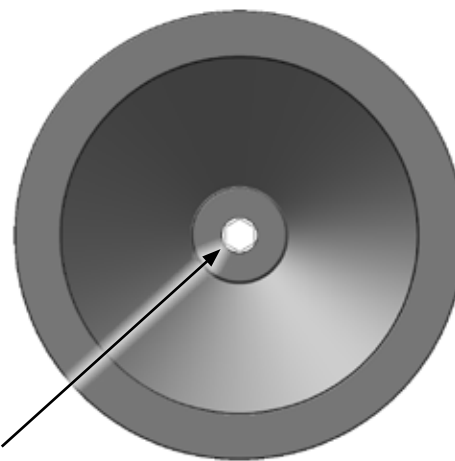

HANDWHEEL

HANDSWITCHES

Two handswitches allow local electric control at the actuator: a lockable handswitch that can be set to STOP/LOCAL/REMOTE, and an OPEN/CLOSE handswitch that controls the actuator in LOCAL mode.

In STOP, the motor is blocked from running.

In LOCAL, the OPEN/CLOSE handswitch controls the actuator and may be set to operate in latching or non latching mode. The OPEN/CLOSE handswitch is also used for configuration/setup. To prevent local control, the handswitch may be locked in the REMOTE position.

In REMOTE, the actuator is controlled by a remote signal. The remote signal can position the actuator only when the handswitch is in the REMOTE position.

(Locked Position)

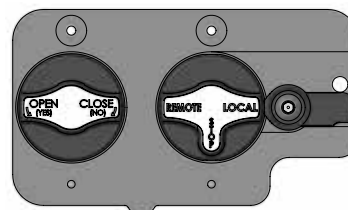

(Unlocked Position)

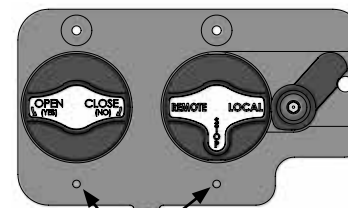

POSITION INDICATING PINS

GENERAL OPERATION INFORMATION

STATUS INDICATION DISPLAY

A 2x16 character LCD screen is used to display actuator status information to the user. During power up and initialization, the actuator startup message will be displayed. The top line of the startup message contains the actuator group number. The bottom line indicates the software version that is currently running on the actuator.



Once the software initialization has finished, the position status replaces the initial message. This contains the current position of the actuator in terms of the "Percent Open" value. For instance if "50.0%" is displayed, the actuator output shaft has moved 50% of the way to the open position relative to the close position:

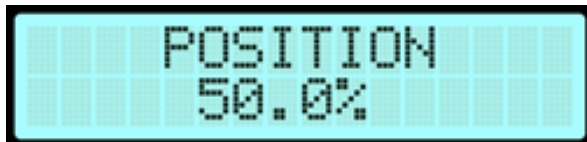

When the percent open is at or above approximately 100.0%, and the Open Action is set to Position, the OPEN indication message is displayed:



When the percent open is at or below approximately 0.0%, and the Close Action is set to Position, the CLOSED indication message is displayed:

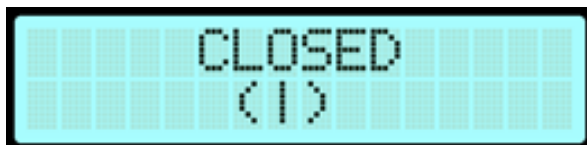

When the percent open is at or above 100.0%, and the Open Action is set to Torque, the opening torque percentage is displayed while the actuator is moving in the open direction:



This message displays the actuator torque as a percentage of the open torque limit. Once the torque reaches or exceeds 100% of the open torque limit, the OPEN status message will appear and the actuator will stop movement.

When the percent open is at or below 0.0%, and the Close Action is set to Torque, the closing torque percentage is displayed while the actuator is moving in the close direction:

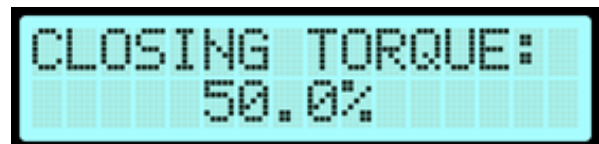

This message displays the actuator torque as a percentage of the close torque limit. Once the torque reaches or exceeds 100% of the close torque limit, the CLOSED status message will appear and the actuator will stop movement.

When a fault occurs that prevents the actuator from operating, a fault message will be displayed on the LCD screen. The source of the fault will be displayed on the top line and the fault type will be displayed on the bottom line:



NOTE: Once a fault occurs in the system, the system is prevented from operating without operator intervention. Faults may be cleared by the user if the fault is no longer occurring in the actuator. To clear the fault, set the handswitch to STOP, then hold the OPEN/CLOSE handswitch in the OPEN or CLOSE position for at least 3 seconds. The display should revert back to the POSITION status indication if the fault has successfully cleared.

INSTALLATION Mechanical

Beck Group 88 actuators may be installed in any orientation, because the gearing does not require an oil bath. Refer to the outline dimension drawings for physical dimensions and required clearances.

VALVE ACTUATOR INSTALLATIONS



CAUTION

Working with valves installed in a pipeline can be dangerous. Take appropriate precautions when mounting to installed valves.

When mounting an actuator on a valve, refer to the valve manufacturer's maintenance manual for specific valve-related instructions. Consult the Beck Valve Mounting Specification sheet shipped with the actuator for specific instructions on assembly of the Beck actuator and mounting hardware to the valve.

It is good practice to remove the valve from service, if possible.

UNITIZED VALVE/ACTUATOR ASSEMBLY INSTALLATION

Inspect the valve and pipe flanges to ensure they are clean. Be certain that other pipelines in the area are free from pipe scale or welding slag that could damage the gasket surfaces.

Carefully lift the assembly and position the valve in the pipeline. Install and tighten the flange bolts according to the valve and/or gasket manufacturer's instructions.

NOTE: The valve may have undergone temperature changes in shipment. This may result in seepage past the stem seals. Refer to the valve manufacturer's maintenance instructions for packing adjustments, if required.

DIRECTION OF TRAVEL

The image below shows the default CW/OPEN direction of travel looking up into the actuator. Note that after OPEN & CLOSE positions are configured, the direction of travel can be changed.



Beck Group 88 actuators are shipped fully assembled and ready for installation when stem thread information has been provided for machining the stem nut. A detailed Valve Mounting Specification (VMS) is typically provided.

1. A crane/hoist with a minimum rated capacity of 500 lbs. will be needed to lift the actuator.
2. Ensure the mounting surface of the valve is secure and free of debris.
3. Ensure the valve stem is free from debris and properly lubricated as per the valve manufacturer's specifications.
4. Install mounting plates/bracket with provided hardware as detailed in the VMS instructions.
5. For non-rising stem or additional gearbox applications, install the stem adapter onto the valve or gearbox stem. For rising stem applications, thread the thrust module down from the top of the valve stem until it meets the mounting surface. Align the thru holes in the mounting surface to the tapped holes in the thrust module.
6. For non-rising stem or additional gearbox applications, skip to step 7. Secure the thrust module to the valve using the (4) 5/8-11 screws with washers (provided). Tighten the screws to 100 lb-ft (135.5 N•m). Ensure the thrust module is secure.
7. Utilizing the lifting bolts on the actuator (see page 5 for location), use the crane/hoist to position the actuator above the valve stem. Ensure the stem is free to pass through the actuator without obstruction.
8. Carefully lower the actuator over the valve stem until the output shaft reaches the spline of the stem nut. Using the actuator handwheel (see page 5 for location), rotate the output shaft until it meshes with the spline.
9. Carefully, continue lowering the actuator until the gearbox meets the flange of the thrust module. Confirm desired orientation by aligning the thrust module with the appropriate tapped holes in the gearbox.
10. Secure the actuator to the thrust module using the (4) 5/8-11 screws and washers provided. Tighten the screws to 100 lb-ft (135.5 N•m). Ensure the actuator is properly secured to the thrust module.
11. Place cover over the valve stem and secure onto the cover adaptor using the provided hose clamp.
12. Ensure all weep holes are free of obstructions in the adaptor.

INSTALLATION Electrical



WARNING

LETHAL VOLTAGE POTENTIAL!
Before removing the terminal cover, ensure that the actuator is disconnected from power.

POWER QUALITY

Power quality disturbances such as power outages, transient voltages, harmonic distortions, and electrical noise will adversely affect the actuator performance. Protecting the actuator from these conditions can reduce downtime and promote longer life for the equipment. Following the industry-accepted standards below will help protect the actuator.

- ✦ Select wiring materials according to the correct ampacity ratings dictated by national and local regulations.
- ✦ Shielded, twisted pair cables can be used for signal connections to avoid being affected by electrical noise. These signal wires, based on Noise Susceptibility Level (NSL) per IEEE-518, fall into the level 1 classification. A braided shield will be more effective than a wrapped foil shield. Signal wire shields should be connected to the actuator casting grounding screw. If grounding at the signal source is required, then the shield should not be grounded at the actuator.
- ✦ Raceways such as conduits and trays must be grounded at both ends to properly meet immunity requirements.
- ✦ A power ground connection should be made between the power source and the Beck actuator. Grounding connections including wire and metal conduit are permitted, but the actuator-grounding conductor may not be connected to a structured metal frame of a building.
- ✦ Surge suppression equipment that meets Underwriters Laboratory (UL) Standard 1449 may be used to protect against transient voltage conditions.
- ✦ Power Conditioners may be used to regulate the supply voltage and maintain a constant voltage level. They are helpful in protection against voltage sags and swells, as well as some measure of electrical noise protection.
- ✦ Harmonic filters may be used to minimize the effects of supply voltage waveform distortions and are used in applications that incur a large amount of high-frequency electronic noise.

ELECTRICAL INSTALLATION

Three 1" N.P.T. conduit connections are provided for power and signal wiring to the actuator. Conduits should be routed from below the actuator so that condensation and other contaminants flow away from the conduit. All conduit entrances must be properly sealed in accordance with National Standards or Regulatory Authorities.

Power and signal wires should be routed to the actuator separately and be either shielded cables or installed in conductive conduit and/or cable trays.

Refer to the wiring diagram furnished with the Beck actuator (inside of the terminal cover) for proper power and signal connections. If there is no wiring diagram available, you may obtain a copy from Beck by providing the Serial number of the actuator.

For maximum safety, the Beck actuator body must be grounded. Use the green grounding screw in the wiring compartment of the actuator.

TERMINAL SCREW TORQUES

Each terminal screw should be torqued to the proper specification upon landing the wire.

TERMINALS	TORQUE	
	(LB-IN)	(N•M)
1-3	16	1.8
4-41	12	1.4



CAUTION

Always close covers immediately after installation or service to prevent moisture or other foreign matter from entering the actuator.

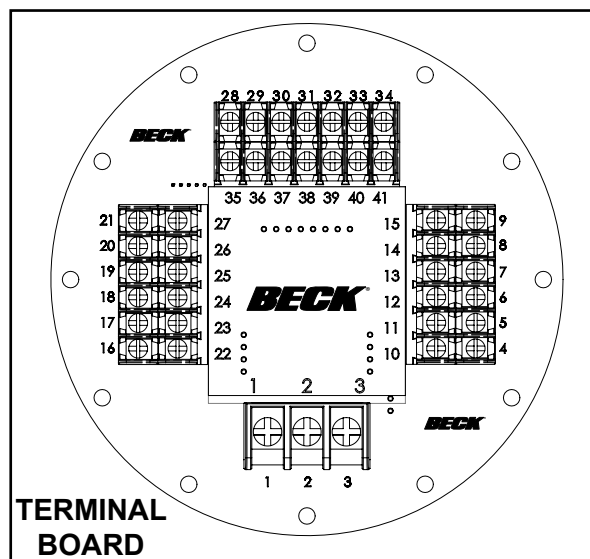

INSTALLATION Wiring

TERMINAL CONNECTIONS

The terminal blocks are located in a separate, protected compartment behind a threaded cover at the front of the actuator. AC line voltage connections are made on terminal designations 1–3 (on the bottom of the board - see page 12).

Terminal screws will accept standard spade or ring terminals. Terminals 4 through 41 accommodate #22 AWG and will accept #12–22 AWG (3.31–.326 mm²). Terminals 1 through 3 accommodate #18 AWG and will accept #8–18 AWG (8.36–.823 mm²). For wiring versatility, the screw-down clamp design will also accept unterminated wire.

A typical wiring diagram is shown on page 14.

Option 3 Actuators (Model 88-203)

Option 3 actuators allow for discrete open/close remote operation. The actuator may be operated using an external source (customer-supplied 120 VAC) or the internal source (actuator-supplied 120 VAC).

Using an external source: Connect the 120 VAC neutral to terminal (25). Connect 120 VAC line voltage to close (22), open (23), stop/maintain (24), and ESD (26) to perform their respective functions.

Using the internal source: The 120 VAC line voltage may be accessed at terminal (27). Connect terminal (27) to close (22), open (23), stop/maintain (24), and ESD (26) to perform their respective functions. Terminal 25 is not connected in this configuration.

The Remote Source must be configured to Discrete (default, see page 32). Discrete remote commands will then be accepted when the REMOTE/STOP/LOCAL handswitch is placed in the REMOTE position.

Open and close interlocks are also provided. See the Actuator Configuration section on page 23 for a functional description of the interlocks. The interlocks are disabled by default, but can be enabled or disabled in the configuration menu (see page 32).

Option 9 Actuators (Model 88-209)

Option 9 actuators (equipped with an Analog Interface board) allow for modulating operation by connecting a 4–20 mA input signal at terminals 36 (+) and 35 (–). A 4 mA signal will position the actuator to 0% (the configured Closed position) and a 20 mA signal will position the actuator to 100% (the configured Open position). Any signal between 4–20 mA will cause the actuator to position proportionately; e.g., 12 mA will result in the actuator positioning to 50%.

A 4–20 mA feedback position signal is also available at terminals 38 (+) and 39 (–). The feedback is scaled the same as the input; i.e., an output of 4 mA indicates the actuator is at 0%, 20 mA = 100%, etc.

The Remote Source must be configured to Analog (see page 32). Analog commands will then be accepted when the REMOTE/STOP/LOCAL handswitch is placed in the REMOTE position.

When wiring is complete, replace the terminal compartment cover as follows:

1. Ensure that the O-ring is seated properly in its groove on the cover (see page 18).
2. Apply a layer of Parker Super O-Lube (SLUBE 884-2) or equivalent to the O-ring.
3. Carefully thread the cover onto the terminal housing until it is flush with the housing—this may require utilization of a long shafted screwdriver or small diameter bar placed across the grooves in the cover to provide sufficient leverage.

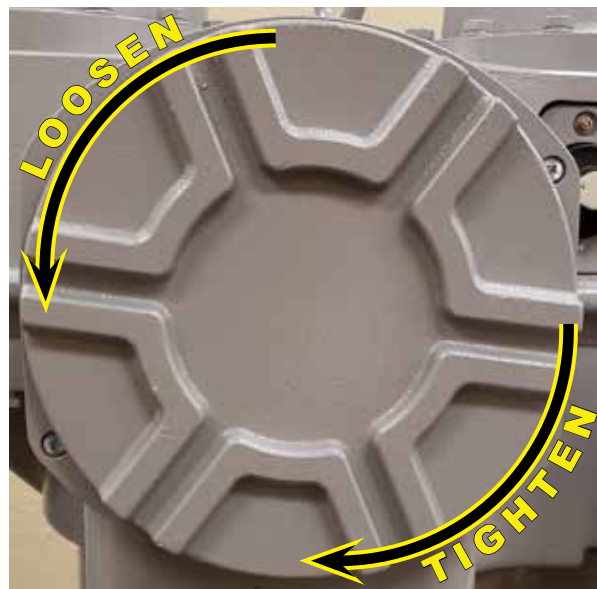

TERMINAL COMPARTMENT COVER

INSTALLATION Wiring

TYPICAL WIRING CONNECTIONS

(Each actuator has a specific wiring diagram on the inside of the terminal compartment cover)

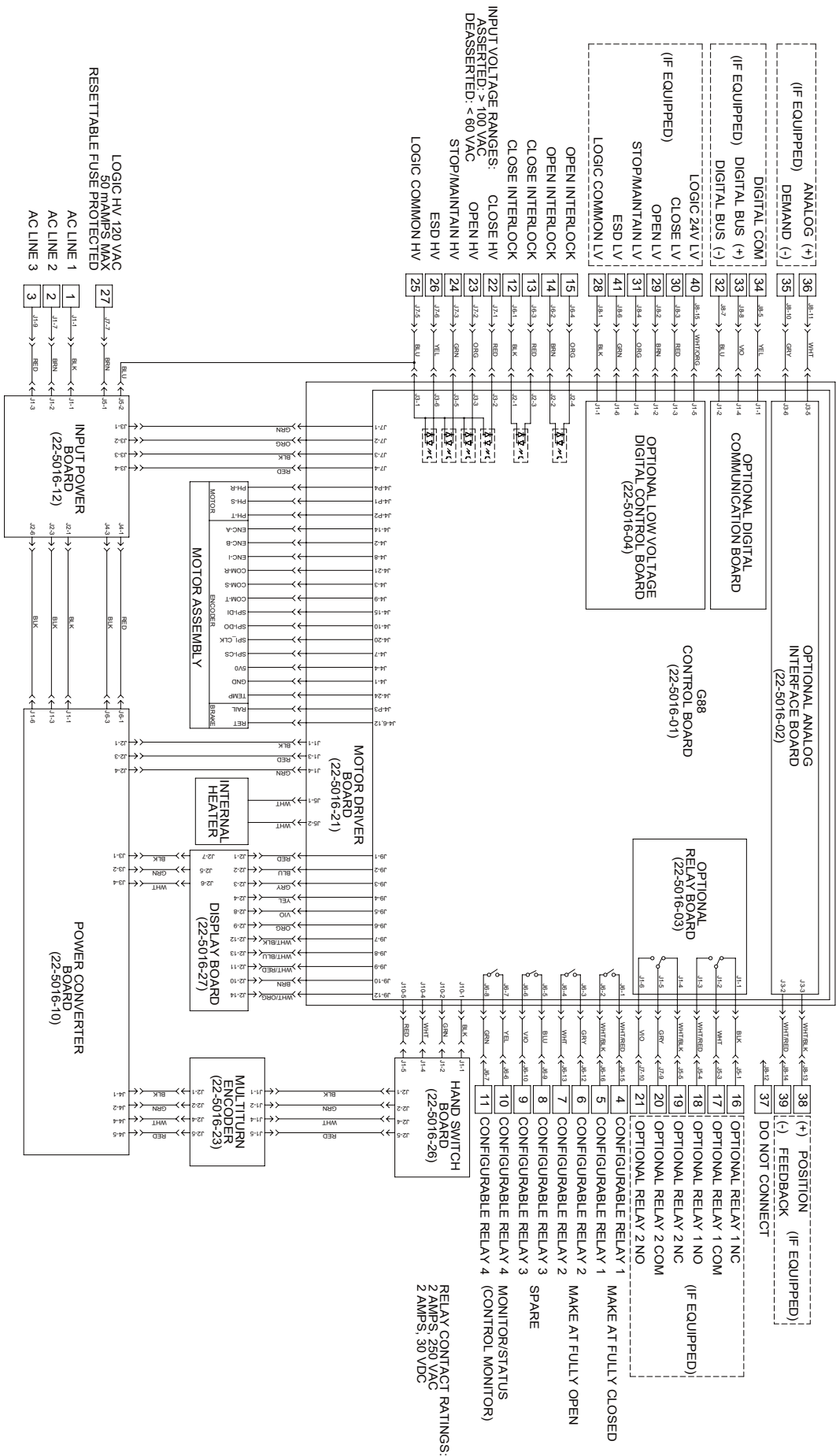

QUICK CONFIGURATION GUIDE

INTRODUCTION

The Beck Group 88 allows the user to perform a quick configuration of the actuator. In this mode, the following key actuator configurable variables are modified by the user:

Torque Limit: Set as a percentage of the full torque rating of 250 lb-ft (339 N•m). The value entered will apply to both the Open and Close directions. Acceptable value is 10 to 100%.



CAUTION

If the torque limit is set too high, equipment may be damaged.

Velocity Limit: Set as a percentage of the full velocity rating of 60 RPM. The value entered will apply to both the Open and Close directions. Acceptable value is 10 to 100%.

Open/Close Action: Set as either "Position" or "Torque", this variable defines how the actuator will determine when the Open or Close movement is complete. When set to "Position", the actuator will complete the movement when the output shaft Open or Close position has been reached. When set to "Torque", the actuator will complete the movement when the output shaft Open or Close position has been achieved *and* the output torque has reached the Torque Limit value.

When configuring performance variables, select NO to modify the value when prompted. Values will increment each time NO is selected. When a NO command is continuously applied, the value will increase more rapidly. Select YES to set the desired value once displayed.

Once the performance variables are chosen, the Open and Close positions can then be set. During the quick configuration, the actuator has the ability to move to any location between 0 to 4000 turns. The Actuator Position will be displayed in terms of the current turns position, as shown below. The Actuator Position in this example is currently at 2000 Turns, meaning it is in the middle of the 4000 Turns range.

Using the handswitches, an Open command will drive the output shaft CW, which will increase the Actuator Position. A Close command will drive the output shaft CCW, which will decrease the Actuator Position.

ENTERING THE QUICK CONFIGURATION MENU

There are two ways to enter the actuator quick configuration mode. The first way is accessed when the Group 88 is powered up for the first time without any configuration settings. The following display message will appear (after the initial splash screen):

Use the OPEN/CLOSE handswitch to select OPEN to respond YES and CLOSE to respond NO. The REMOTE/STOP/LOCAL handswitch needs to be set to STOP in order for this option to display.

If NO is selected, the default configuration values will be used. If these values are also not changed using the *main* configuration menu, the quick configuration message will appear again on the next power up. If YES is selected, quick configuration mode will be entered. Skip to the next section, "PERFORMANCE VARIABLES CONFIGURATION PROCEDURE".

The second way to enter quick configuration mode is through the main configuration menu. Enter this mode in the following way:

Set the REMOTE/LOCAL/STOP handswitch to STOP. Then use the OPEN/CLOSE handswitch to quickly provide the following command sequence: OPEN, CLOSE, OPEN. The following message will appear:

Select NO to progress to the next menu. The following message should then appear:

Select NO to progress to the next menu. The following message should then appear:

Select YES to enter the Calibration Menus. A 4-digit passcode must then be entered. Select NO

Cont'd

QUICK CONFIGURATION GUIDE

ENTERING QUICK CONFIG. MENU, cont'd

to modify the passcode input value. Select YES to commit. The 4 digits are entered individually. The required passcode is the same as the passcode to enter the "Change Settings" menu. It is "0000" by default.

ENTER PASSCODE:
DIGIT 1 OK? 0

Once the passcode has been successfully entered, the user will be asked if they would like to enter the Quick Configuration menu:

ENTER QUICK
CONFIGURATION?

Select YES to enter the Quick Configuration Menu.

PERFORMANCE VARIABLES CONFIGURATION PROCEDURE

The quick configuration mode is now entered. Follow the instructions below to modify the performance variables:

A message will appear asking if the Torque Limit setting is acceptable. Select NO to modify the value of the Torque Limit. Select YES once the desired value is displayed.

TORQUE LIM OK?
10.0% RATED

A message will then appear asking if the Velocity Limit setting is acceptable. Select NO to modify the value of the Velocity Limit. Select YES once the desired value is displayed.

VEL LIM OK?
50.0% RATED

A message will then appear asking if the Open Action is set properly. Select NO to toggle between "Position" and "Torque". Select YES once the desired value is displayed.

OPN ACTN OK?
POSITION

A message will then appear asking if the Close Action is set properly. Select NO to toggle between "Position" and "Torque". Select YES once the desired value is displayed.

CLS ACTN OK?
POSITION

Once this has been selected, the "PERFORMANCE VARIABLES CONFIGURATION PROCEDURE" has completed and the "POSITION CONFIGURATION PROCEDURE" will begin.

NOTE: The REMOTE/STOP/LOCAL handswitch must be set to STOP during the entire Quick Configuration process. At any point during the Quick Configuration, if the handswitch is moved out of the STOP position, the Quick Configuration will be terminated. Any changes made will not be committed.

POSITION CONFIGURATION PROCEDURE

Follow the instructions below to modify the Open and Close positions.

The actuator will display the message seen below, asking the user if they would like to set the Close Position first:

SET CLOSE POS
FIRST?

Select YES to begin the Close Position set process. Select NO to change the display to the following:

SET OPEN POS
FIRST?

Select YES to begin the Open Position set process. Selecting NO will change the display back to the "SET CLOSE POS FIRST?" prompt.

A prompt will appear to move the actuator to the desired Close or Open position. The current Actuator Position will also be displayed. The Actuator Position is shown in terms of turns of the actuator, which can be driven anywhere from 0 to 4000. In this example, the Close Position will be set first. Once committed, the Close Position will be set to the Actuator Position value that is displayed.



MOVE TO CLS POS
ACT POS: 2000.0

Regardless of the position being set, an OPEN command will drive the output shaft CW, which will increase the Actuator Position. A CLOSE command will drive the output shaft CCW, which will decrease the Actuator Position.

If the torque limit is reached while setting positions, a message will appear indicating the torque limit has been reached:



TRQ LIM REACHED
MODIFY TORQUE?

Select NO to attempt to move the actuator to the Close Position once again without modifying the Torque Limit. Select YES to bring the Torque Limit modification menu back up:



TORQUE LIM OK?
10.0% RATED

Once the torque limit has been modified to the desired value, the display will prompt the user to move the actuator to whichever position was being set when the torque limit was reached. In this case, the user was setting the Close Position:



MOVE TO CLS POS
ACT POS: 2000.0

Once the actuator has been driven to the desired Close position, use the OPEN/CLOSE handswitch to quickly provide the following commands: OPEN, CLOSE, OPEN. The following message will be displayed:



COMMIT CLOSE
POSITION?

Select YES to temporarily commit the Close Position. Select NO to select another Close Position.

If YES is selected, the menu will progress to a prompt to set the Open Position, which will generate the following display message:



MOVE TO OPN POS
ACT POS: 2014.3

An OPEN command will drive the output shaft CW, which will increase the Actuator Position. A CLOSE command will drive the output shaft CCW, which will decrease the Actuator Position.

NOTE: Once the Quick Configuration has been completed, it will no longer appear at power up. However, all parameters may be accessed again using the main configuration menu. See Appendix.

Once the actuator has been driven to the desired Open position, use the OPEN/CLOSE handswitch to quickly provide the following commands: OPEN, CLOSE, OPEN. The following message will be displayed:



COMMIT OPEN
POSITION?

Select YES to temporarily commit the Open Position. Select NO to select another Open Position.

Once the Open Position has been committed, the following message will be displayed:



CONFIG COMPLETE
COMMIT VALUES?

Select NO to restart the Quick Configuration menu. Select YES to complete the Quick Configuration and commit the values to the flash memory. At this point, normal operation can commence.

NOTE: If the Close action is set to "Torque", during normal operation the output shaft will keep moving past the set Close position until the Close Torque limit has been achieved. Only once these two requirements have been met does the actuator consider itself fully Closed and stop movement. The Close Position should therefore be set an appropriate distance away from the desired position at which the actuator will stop movement when Closing.

MAINTENANCE

O-RING (TERMINAL COMPARTMENT)

When accessing the terminal compartment, inspect the O-ring on the terminal compartment cover for damage. In order to protect internal components, a damaged O-ring should be replaced, as described below.

Remove and discard the old O-ring. When installing the new O-ring, ensure that the ring is completely over all of the threads and seated properly in its groove (see below). Apply a layer of Parker Super O-Lube (SLUBE 884-2) or equivalent. Carefully thread the cover onto the terminal housing—this may require utilization of a long shafted screwdriver or small diameter bar placed across the grooves in the cover to provide sufficient leverage.

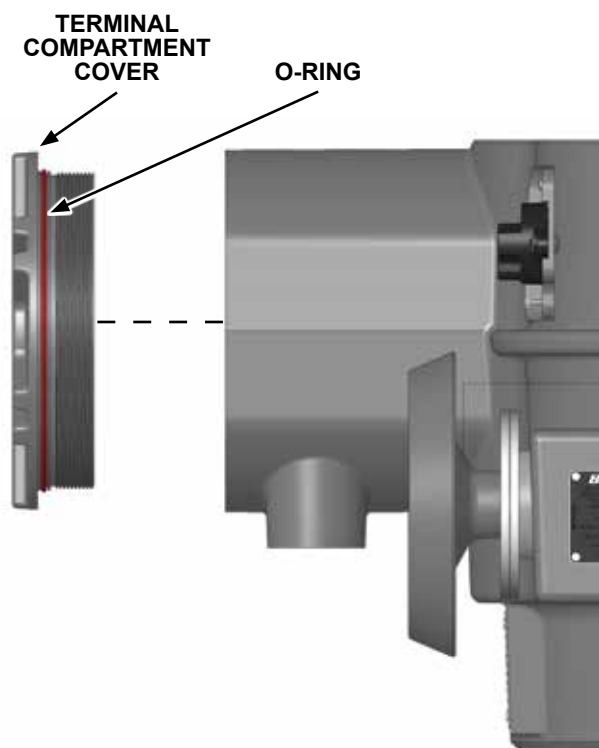

HANDSWITCH ASSEMBLY

In the unlikely event that a handswitch requires replacement, a replacement kit is available. The kit includes a complete handswitch assembly consisting of both magnetic handswitches mounted on a plate along with two screws for mounting. No wiring or actuator penetration is necessary.

Remove the old handswitch assembly by loosening and removing the two #6 screws and lifting the assembly out of the locating fin slot (shown below).

Install the new handswitch assembly by inserting the locating fin in the slot and aligning the screw holes. Use the (2) provided lock washers, flat washers and screws (as shown below) to secure the assembly. Torque to 10 lb-in (1.13 N•m).

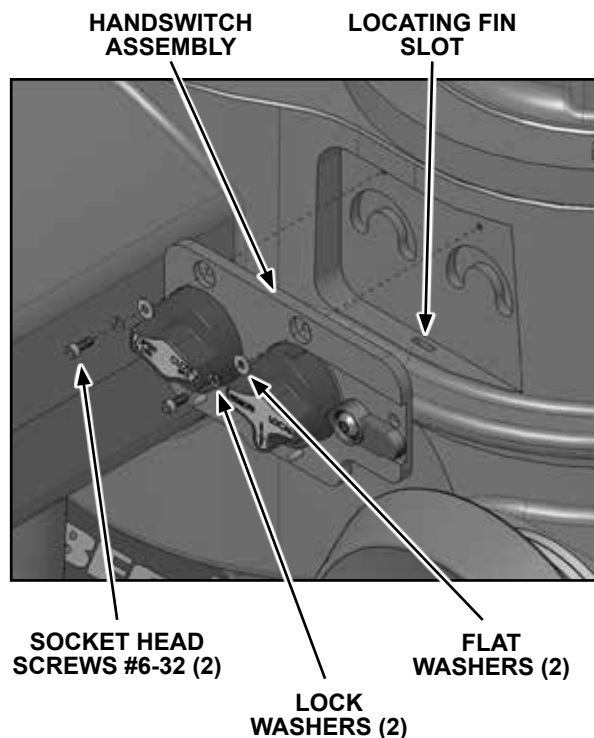

FUSES

To replace fuses in the G88 actuator, follow the instructions below:

1. Remove power from the actuator and wait at least 60 minutes to allow the stored energy to dissipate.



WARNING

Lethal voltage is present within the actuator. Wait at least 60 minutes after power removal before proceeding.

2. Remove and retain the four 5/16-18 hex head screws securing the enclosure which houses the display. Remove the enclosure.



CAUTION

The fit between the display enclosure and the actuator body is extremely tight and, therefore, susceptible to jamming. Do not force the cover off by prying or using a hammer, as this will result in irreparable damage to the cover and/or actuator base. Remove by hand only.

3. Set the cover on its side on the top of the actuator, being careful not to stress the wires connecting it to the actuator body.

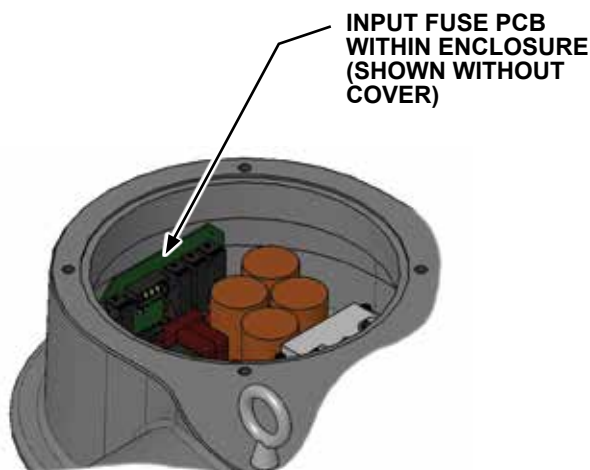

4. Remove and retain the cap head screw securing the Input Fuse PCB assembly (22-5016-13) to the Input Power PCB (22-5016-12). Remove the Input Fuse PCB by gently pulling it free from the connector.

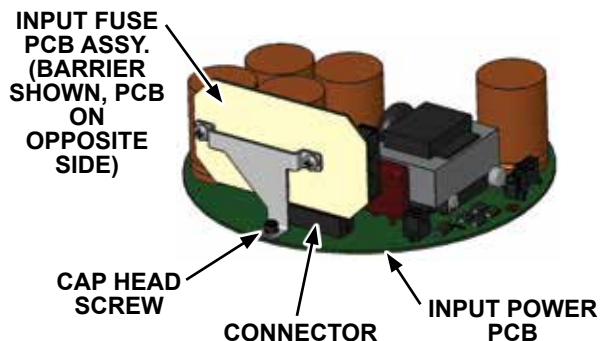

5. Replace any open fuse. Remove the fuse cover by gently squeezing it on either end and pulling the cover away from the board. Replace the fuses only with the appropriate type (shown on the PCB board).

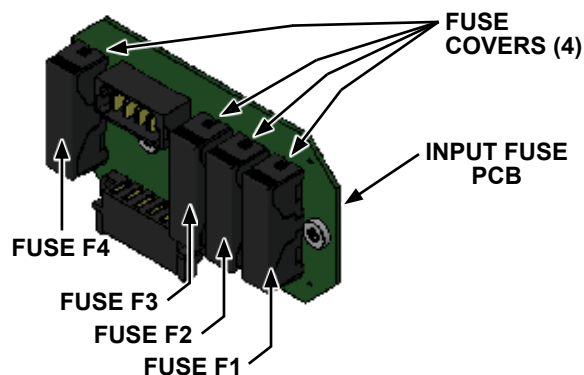

6. When finished replacing the fuse(s), reinstall the Input Fuse PCB assembly by securing it to the connector and tightening the cap head screw to 10 lb-in (1.13 N•m).
7. Carefully place the enclosure back on the actuator body being careful not to pinch the wires. Secure the enclosure to the actuator using the four 5/16-18 hex head screws from step 2. Tighten to 10 lb-ft (14 N•m).

MAINTENANCE

THRUST MODULE ASSEMBLY

If the stem nut needs to be removed for machining or needs to be replaced, the stem nut must first be removed from the thrust module.

If the actuator is already installed on a valve, it must be removed per the instructions on page 11. Next, remove the thrust module assembly from the actuator.

Following are instructions for disassembling the thrust module assembly. Refer to the image on page 21 for part identification. *Note: For easier disassembly, it is recommended that the thrust module be turned upside down as depicted. Protect the splined portion of the stem nut, which will make contact with the work surface. Retain all removed parts for later reassembly.*

Required Tools and Materials:

- 1/8" Hex Key
- Flathead Screwdriver
- Parker S-Lube 884-2 (or equivalent)
- Loctite 222 (or equivalent)

Disassemble the thrust module:

1. Remove the (2) #10-24 button head screws from the mounting bracket. *Note: The module housing will no longer be supported and will drop off of the assembly.*
2. Remove the mounting bracket from the thrust module assembly.
3. Carefully remove the stem nut and bearing assembly from the module housing.
4. Turn the stem nut and bearing assembly right side up (opposite of image). Remove the retaining ring holding the split collars onto the stem nut. This may be accomplished by pushing a flat head screwdriver into the gap between the split collars and gently pushing the retaining ring away from the stem nut, then removing the ring by hand.
5. Remove the bearing assembly from the stem nut.
6. Remove the -237 O-ring and the -145 O-rings (2) from the stem nut.
7. The stem nut is now ready to be machined (or replaced). **Note: The maximum thread size cannot exceed a 2 inch nominal thread or 1 3/4 inch keyed shaft.**

After the stem nut has been machined (or if the stem nut is being replaced), follow the procedure below for reassembling the thrust module. *Note: For easier assembly, it is recommended that the first 7 steps be completed with the components right side up.*

Reassemble the thrust module:

1. Lubricate with Parker S-Lube 884-2 (or equivalent) and install the -237 O-ring into the groove on the widest part of the stem nut.
2. Lubricate with Parker S-Lube 884-2 (or equivalent) and install one of the -145 O-rings into the next closest groove of the stem nut.
3. Install the stem nut into the bearing assembly as shown on page 21.
4. Insert both split collar pieces around the groove in the stem nut. **Note: Ensure the larger diameter face of the split collar is facing the bearing assembly (facing away from the module housing).**
5. Install the retaining ring in the groove around the split collar pieces. *Note: The gap in the retaining ring should be approximately 90° from the gaps in the split collar pieces.*
6. Lubricate the remaining -145 O-ring with Parker S-Lube 884-2 (or equivalent).
7. Install the -145 O-ring in the remaining groove on the stem nut. **Note: Do not place the O-ring in the gap immediately beneath the spline teeth.**
8. Insert the stem nut and bearing assembly into the thrust module housing. *Note: At this point, it is recommended to orient the assembly and thrust module housing upside down. Lift and support the edges of the housing so that the stem nut can pass through, allowing the assembly to sit flush in the housing.*
9. Insert the mounting bracket into the thrust module assembly, aligning the bracket cutouts with the tapped holes in the thrust module housing.
10. Apply Loctite 222 (or equivalent) to the (2) #10-24 button head screws and install in the tapped holes in the thrust module housing. Tighten to 21 lb-in (2.37 N•m).

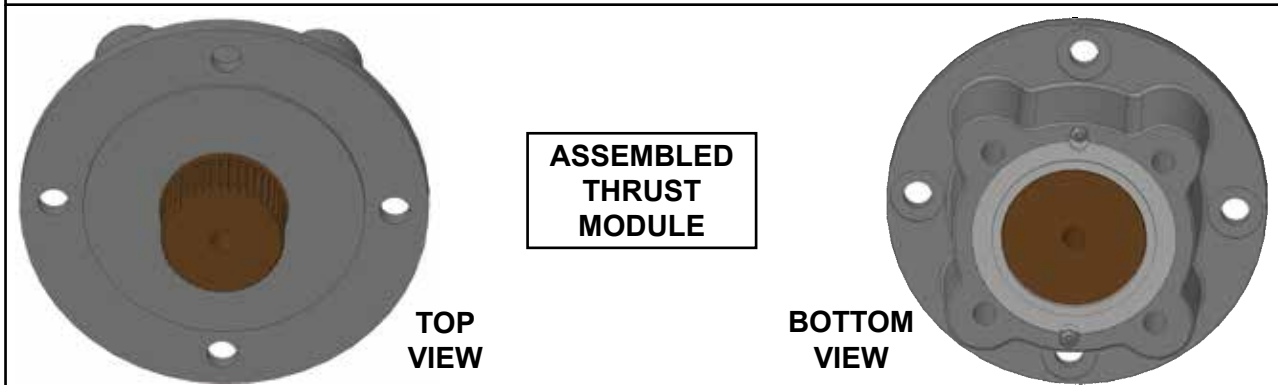
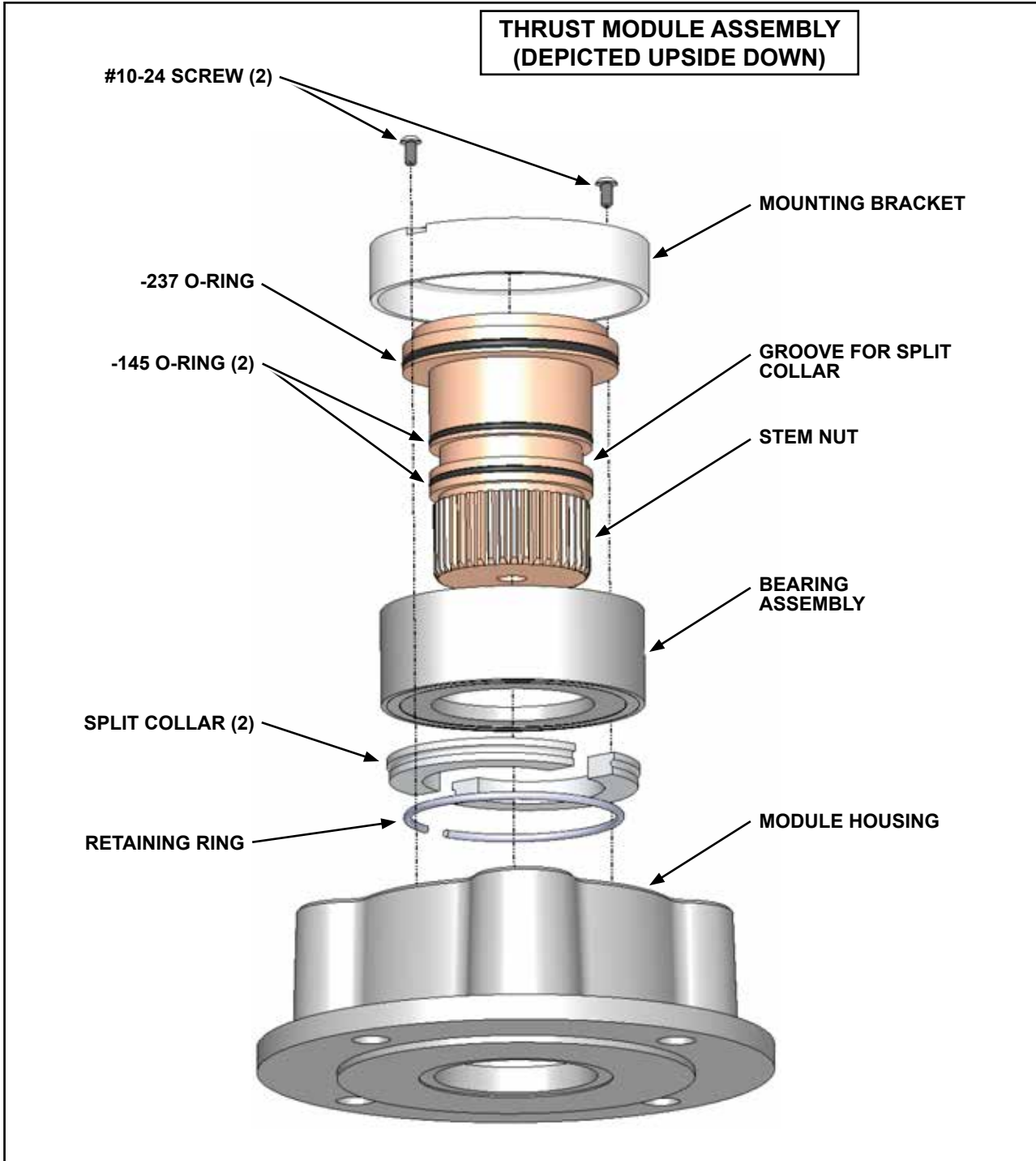

MAINTENANCE

SPARE PARTS

The table below lists customer replaceable spare parts available for the Group 88 actuator.

SPARE PARTS

Description	Part Number
Circuit Board Kits	
Motor Driver Assembly	Contact Factory
Encoder Assembly	Contact Factory
Power Converter Assembly	14-9998-20-KIT
Analog Interface Assembly	20-3188-06
Input Power Board	Contact Factory
Input Fuse Board	Contact Factory
Handswitch Board	Contact Factory
Fuses	
F1–F3 (8A, 600VAC / 500VDC slow)	11-1372-37
F4 (100mA, 1kVAC slow)	11-1372-38
Handswitch Assembly	14-9988-26
Handwheel	15-1062-66
Motor Assembly	14-9998-23
O-ring (Motor Assembly & Power Converter)*	14-9840-70
O-ring (Terminal Compartment)*	14-9840-73
O-rings (Stem Nut)*	
-237	14-9840-77
-145 (2)	14-9840-76
Stem Cover Assembly	20-3188-05
Top Cover Assembly	20-3188-02
Stem Cover Bracket Assembly	20-3188-04
Stem Nut (Blank)*	14-9688-23
Thrust Module Assembly	14-9988-27

* Recommended spare part

TROUBLESHOOTING

Should the Beck actuator fail to operate as expected, the information below combined with the chart beginning on the following page, provide a systematic method for isolating and resolving actuator problems.

Main voltage and internal power supplies

Should the actuator fail to operate after power is applied, the first place to look is the status indication display. When operating properly, the status indication display will be illuminated and the display will provide the current position of the output shaft.

If the display is not illuminated, then power is not reaching the actuator. This may be caused by the fuse to the internal power supply being open, or an internal power supply or board problem. Verify that the actuator is receiving the power as required on the nameplate. If the power is correct and the fuse for the logic power supply is not open (see Maintenance Section guidance), contact a Beck Application Engineer.

Should the display show something other than the output shaft position status, see the troubleshooting chart on the next page for possible causes and corrections.

Handswitch operation

If the actuator appears to be in a locked state, this may be caused by a combination of handswitch position and associated actuator modes. To test the actuator, ensure the REMOTE/STOP/LOCAL mode switch is in the LOCAL position, then turn the OPEN/CLOSE switch to either position and hold it in place. The actuator will start to move in that direction after a one second delay.

Display of internally generated faults

Should the status indication display show something other than the output shaft position status, see the troubleshooting chart on the next page for possible causes and corrections.











Actuator configuration

If the actuator is in REMOTE mode and is not moving when commanded, it may be due to the configuration of the Inhibit, Interlocks and/or Stop inputs. Because the actuator will always respond in LOCAL mode, first check the problem by turning the REMOTE/STOP/LOCAL switch to the LOCAL position. Then turn the OPEN/CLOSE switch to either position and hold it in place. If the actuator still does not move, refer to the troubleshooting chart beginning on page 24. If the actuator moves, the problem is likely attributable to the configuration of the inputs (below) when in REMOTE mode.













The inputs and polarities are set by use of the configuration (see Configuration Menu Tree Appendix for details). The key settings are found in the Change Commands column.

1. **Inhibit time:** This feature prevents the actuator from operating for a preconfigured time after receipt of a command signal (up to 200 seconds). It is recommended that this setting be kept at 0 (zero) seconds until the actuator can be controlled remotely.
2. **Interlocks:** If the interlocks are enabled, and the interlock in the direction of the requested move is not asserted (energized), the actuator will not move. Open and Close interlocks are asserted by applying >100 VAC to the appropriate wiring terminals (Open terminals are 14 and 15, Close terminals 12 and 13; the voltage and neutral line may be applied to either of the applicable terminals—see the wiring diagram on page 14). If the interlocks are enabled, ensure the proper terminals are appropriately wired. If the interlocks are not enabled, the actuator will be able to move regardless of the wiring of the terminals.
3. **Stop:** This feature will stop the actuator from operating. If this feature was set as a failsafe to stop the actuator when power is lost, >100 VAC should have been applied to wiring terminal 24 and the polarity set to REMOVED (STOP POL, see page 32). If this feature was set to stop the actuator when powered, then >100 VAC should have been applied to wiring terminal 24 and the polarity set to APPLIED (STOP POL, see page 32). Ensure this feature is set appropriately.

TROUBLESHOOTING









CONDITIONS	POSSIBLE CAUSES	CORRECTIONS
1. Display is blank and not illuminated.	<ul style="list-style-type: none"> a. No power is being applied to the actuator. b. Fuse F4 is open. c. Main control board malfunction. d. Display malfunction. 	<ul style="list-style-type: none"> a. Make sure the proper power is being applied (see nameplate). b. Replace F4 (see Maintenance section). c. Replace main control board (contact the factory). d. Replace display board (contact the factory).
2. Display indicates: 	<ul style="list-style-type: none"> a. Temporary motor overcurrent. 	<ul style="list-style-type: none"> a. Place actuator in STOP mode. Hold switch in CW position for three seconds to reset. Resume operation.*
3. Display indicates: 	<ul style="list-style-type: none"> a. Temporary motor overcurrent. 	<ul style="list-style-type: none"> a. Place actuator in STOP mode. Hold switch in CW position for three seconds to reset. Resume operation.*
4. Display indicates: 	<ul style="list-style-type: none"> a. Motor commutation sensor error. 	<ul style="list-style-type: none"> a. Place actuator in STOP mode. Hold switch in CW position for three seconds to reset. Resume operation.*
5. Display indicates: 	<ul style="list-style-type: none"> a. If optional analog board is installed, then this board malfunctioned. b. If optional analog board is not installed, actuator is configured for the analog board, which is missing. 	<ul style="list-style-type: none"> a. Place actuator in STOP mode. Hold switch in CW position for three seconds to reset. Resume operation.* b. Reconfigure actuator to remove analog board (see page 32).
6. Display indicates: 	<ul style="list-style-type: none"> a. Display malfunction. 	<ul style="list-style-type: none"> a. Place actuator in STOP mode. Hold switch in CW position for three seconds to reset. Resume operation.*
7. Display indicates: 	<ul style="list-style-type: none"> a. Multi-turn encoder malfunction. 	<ul style="list-style-type: none"> a. Place actuator in STOP mode. Hold switch in CW position for three seconds to reset. Resume operation.*
8. Display indicates: 	<ul style="list-style-type: none"> a. Multi-turn encoder malfunction. 	<ul style="list-style-type: none"> a. Place actuator in STOP mode. Hold switch in CW position for three seconds to reset. Resume operation.*
9. Display indicates: 	<ul style="list-style-type: none"> a. Handswitch module malfunction. 	<ul style="list-style-type: none"> a. Place actuator in STOP mode. Hold switch in CW position for three seconds to reset. Resume operation.*
10. Display indicates: 	<ul style="list-style-type: none"> a. Handswitch module malfunction. b. Handswitch knob is damaged or missing. 	<ul style="list-style-type: none"> a. Place actuator in STOP mode. Hold switch in CW position for three seconds to reset. Resume operation.* b. Replace handswitch assembly (see Maintenance section).
11. Display indicates: 	<ul style="list-style-type: none"> a. Power Converter malfunction. 	<ul style="list-style-type: none"> a. Place actuator in STOP mode. Hold switch in CW position for three seconds to reset. Resume operation.*

* If fault persists, contact the factory.

CONDITIONS	POSSIBLE CAUSES	CORRECTIONS
12. Display indicates: 	a. Input power less than 90% of nominal nameplate value. b. Power Converter malfunction.	a. Make sure the power supplied to the actuator is within the nameplate requirements. b. Place actuator in STOP mode. Hold switch in CW position for three seconds to reset. Resume operation.*
13. Display indicates: 	a. Power Converter malfunction.	a. Place actuator in STOP mode. Hold switch in CW position for three seconds to reset. Resume operation.*
14. Display indicates: 	a. Input power greater than 110% of nominal nameplate value. Could be momentary.	a. Make sure the power supplied to the actuator is within the nameplate requirements.
15. Display indicates: 	a. Input power less than 90% of nominal nameplate value. b. Fuses F1, F2, and/or F3 are open. c. Main control board malfunction.	a. Make sure power supplied to the actuator is within the nameplate requirements. b. Replace open fuses (see Maintenance). c. Replace main control board (contact the factory).
16. Display indicates: 	a. Motor drive drawing excessive current.	a. Place actuator in STOP mode. Hold switch in CW position for three seconds to reset. Resume operation.*
17. Display indicates: 	a. Load is backdriving the actuator.	a. Reduce the actuator speed in the direction the load is backdriving the actuator (see Appendix).
18. Display indicates: 	a. Power Converter malfunction.	a. Place actuator in STOP mode. Hold switch in CW position for three seconds to reset. Resume operation.*
19. Display indicates: 	a. Power Converter malfunction.	a. Place actuator in STOP mode. Hold switch in CW position for three seconds to reset. Resume operation.*
20. Display indicates: 	a. Motor stalled for longer than the 2–300 second configured time limit.	a. Place actuator in STOP mode. Hold switch in CW position for three seconds to reset. Resume operation.*
21. Display indicates: 	a. Redundant position sensors not tracking.	a. Place actuator in STOP mode. Hold switch in CW position for three seconds to reset. Resume operation.*
22. Display indicates: 	a. Multi-turn position sensor has moved beyond the 4,000 turns allowed.	a. Turn the handwheel in one direction until the displayed fault clears and displays the actuator's position. Resume operation.*
23. Display indicates: 	a. Multi-turn position sensor has moved beyond the 4,000 turns allowed.	a. Turn the handwheel in one direction until the displayed fault clears and displays the actuator's position. Resume operation.*

* If fault persists, contact the factory.

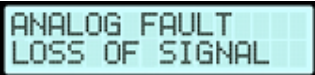
TROUBLESHOOTING

CONDITIONS	POSSIBLE CAUSES	CORRECTIONS
24. Display indicates: 	a. Multi-turn malfunction.	a. Turn the handwheel in one direction until the displayed fault clears and displays the actuator's position. Resume operation.*
25. Display indicates: 	a. Load is backdriving the actuator.	a. Reduce the actuator speed in the direction the load is backdriving the actuator.
26. Display indicates: 	a. Thermal capacity of the motor has been exceeded.	a. The load the actuator is driving has exceeded the capacity of the motor. Wait 15 minutes, then place the actuator in STOP mode. Hold switch in CW position for three seconds to reset. Resume operation.*
27. Display indicates: 	a. Thermal capacity of the motor drive has been exceeded.	a. The load the actuator is driving has exceeded the capacity of the motor drive. Wait 15 minutes, then place the actuator in STOP mode. Hold switch in CW position for three seconds to reset. Resume operation.*
28. Display indicates: 	a. The load is backdriving the actuator.	a. Reduce the actuator speed in the direction the load is backdriving the actuator.
29. Display indicates: 	a. One or more of the Power Supplies are measured as too high or too low.	a. Place actuator in STOP mode. Hold switch in CW position for three seconds to reset. Resume operation.*
30. Display indicates: 	a. The internal temperature exceeds the maximum allowable temperature.	a. Wait 15 minutes to allow the unit to cool down. Place actuator in STOP mode. Hold switch in CW position for three seconds to reset. Resume operation.*
31. Display indicates: 	a. While in Analog mode, the input demand signal cannot be read.	a. Ensure analog input is wired correctly. The fault should clear on its own once a valid input current has been measured.
32. Display indicates: 	a. While the system is communicating over the Bluetooth connection, invalid data has been sent by the external device.	a. Reconnect the Bluetooth application and ensure the latest Bluetooth application is being used.

* If fault persists, contact the factory.

APPENDIX *Bluetooth® App*

The Beck Group 88 Android app provides wireless access to essential configuration and status parameters via **Bluetooth®** technology. The main features include full access to the configuration menu parameters, general status information, PCB serial numbers and software versions, documentation links, and configuration management.

The app contains five main views: Status, Configuration Menu, Documentation, Bluetooth Connection, and Settings.

- The Status view provides information on various status parameters in the actuator such as the current position and internal temperature, as well as the serial number and software version of each PCB.
- The Configuration Menu view contains all of the user-configurable parameters. This view is organized into tabs that are identical to the branches in the configuration menu tree that is accessed via the handswitches.
- The Documentation view contains links for the instruction manuals and wiring diagrams on the Beck website.
- The Bluetooth Connection view handles the connection and allows for setting a nickname for the connected actuator.
- The Settings view contains a theme toggle, configuration management, and an About section. When connected to an actuator, the current configuration can be saved (a saved configuration can be restored or deleted). There is also a feature to reset the parameters to the factory defaults.

The app opens to the Bluetooth Connection view. If not currently connected to an actuator, only the “Connect to a G88 Actuator” button is displayed. If connected, three buttons are displayed: “Connect to a G88 Actuator”, “Disconnect from the G88 Actuator”, and the connected actuator’s info. Connecting to another actuator while currently connected to one automatically disconnects from the current connection without having to manually disconnect.

Connection indicator

- When connected, the Bluetooth icon in the top right corner of the app changes to green. When not connected, the icon changes to yellow.

Connecting to a G88 Actuator

- Before connecting, the actuator must be in Bluetooth mode. To enter Bluetooth mode, set the Remote/Stop/Local handswitch to Stop. It must remain in Stop for the duration of the connection. Then, turn the Open/Close handswitch to Open, Close, Open. This sequence will show the “Change Settings?” prompt on the display. Turn the handswitch to Close/No. The next prompt is “Connect Bluetooth?”. Turn the handswitch to Open/Yes. The actuator is now in Bluetooth mode and displays “Waiting for connection...”.

Note: The actuator will automatically exit Bluetooth mode after 60 seconds if a connection is not established.

- In the app, click “Connect to a G88 Actuator”. If Bluetooth is not enabled, a prompt will ask to turn it on. Accept the prompt to proceed. Declining the prompt exits the connection sequence. The connection dialog shows a list of paired actuators (if previously connected to any) and a scan button. The list displays each actuator’s name/serial number, nickname (if assigned), and MAC address.
- To connect to a paired actuator, click it in the list. To scan for an unpaired actuator that is in Bluetooth mode, click the scan button. The list of found actuators updates in real time as discoverable ones are detected. Click an actuator in the list to connect at any time during the scan.
- The actuator displays a 6-digit pin when the initial connection is established. Enter the pin in the dialog in the app to complete the connection. If the entered pin matches the displayed pin, the actuator displays “Connected to device” and the icon in the top right corner of the app turns green. If the pin was incorrect, the connection is canceled and the process must be restarted.

Disconnecting from a G88 Actuator

- To disconnect, either click the “Disconnect from the G88 Actuator” button or temporarily move the R/S/L handswitch out of Stop mode. Disconnecting changes the Bluetooth icon in the top right to the yellow disconnected icon, and the disconnect button and info button are hidden. The connection will also be dropped when the device is moved out of range of the actuator.

App features are subject to change at any time and may not be directly reflected above. Refer to the documentation in the latest version of the app for feature descriptions. There may be configuration parameters in the latest app that are not applicable to older actuator firmware versions. A message describing this situation is displayed when attempting to set a parameter that is not implemented in the connected actuator’s firmware. The latest app is backwards-compatible with all previous actuator firmware versions. It is recommended to update to the latest app version when receiving a new shipment of actuators to ensure compatibility with the actuator’s firmware. The Android app is available on the Beck website: www.haroldbeck.com.

APPENDIX Configuration Menu Tree

ABRIDGED CONFIGURATION MENU TREE

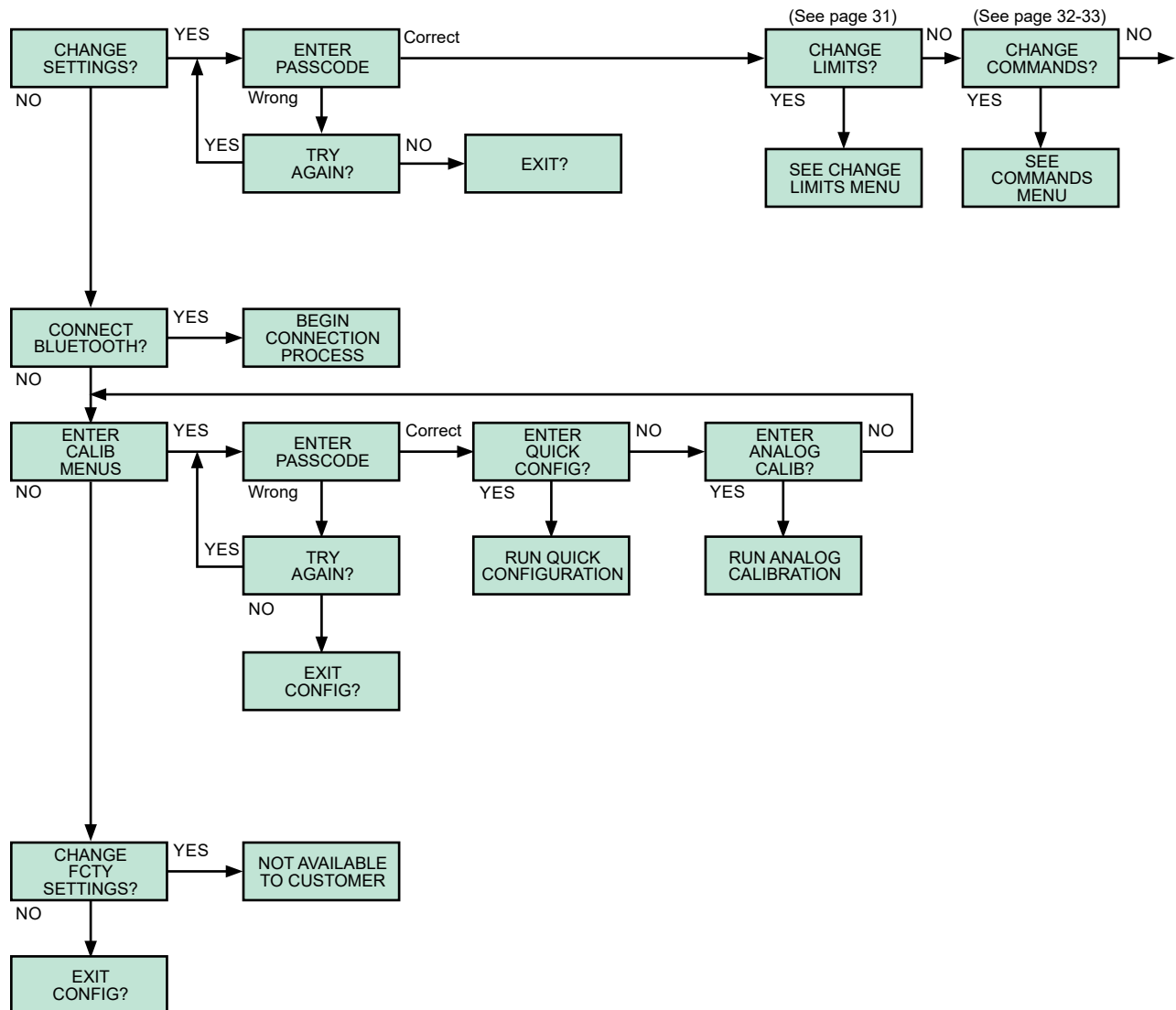

ABRIDGED CONFIGURATION MENU TREE (cont'd)

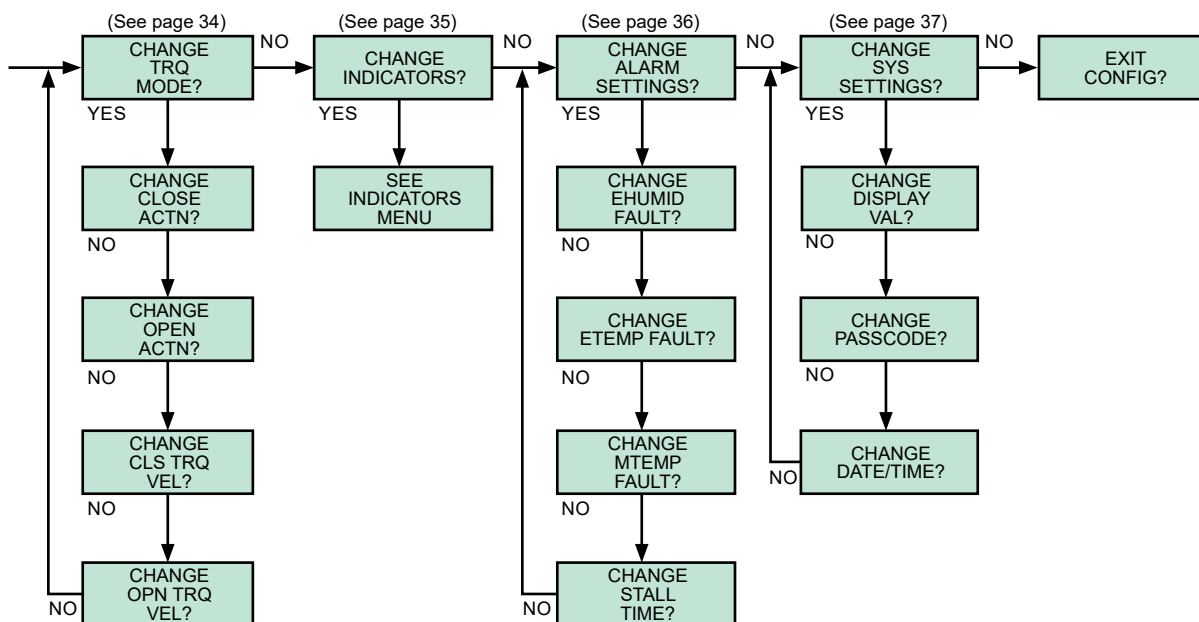

APPENDIX Configuration Menu Details

ACCESSING THE CONFIGURATION MENU TREE

The following instructions detail the steps necessary to access the configuration menus:

1. Place the REMOTE/STOP/LOCAL handswitch in the STOP position.
2. In rapid succession, turn the OPEN/CLOSE handswitch to OPEN, CLOSE, then OPEN. This must be done quickly, staying no more than half a second in each position.
3. If done correctly, the change settings message (below) will display. If not, repeat the above steps until successful.



NAVIGATING THE CONFIGURATION MENU TREE

As the configuration tree is navigated, the display will provide questions that are answered with "YES" or "NO" using the spring return OPEN/CLOSE handswitch. Note that the default passcode for "CHANGE SETTINGS" and "ENTER CALIB MENUS" is "0000".

NOTE: Toggling the OPEN/CLOSE handswitch to the OPEN position indicates "YES", and toggling the handswitch to the CLOSE position indicates "NO". For reference, these values are printed on the handswitch.

When a parameter is to be changed, the display shows the current parameter name in the form of a question on the first line, with the value of the parameter shown on the second line. For example, changing the torque limit parameter would be displayed as follows:



If the current value is acceptable, toggle the handswitch to YES. To change the value, toggle the handswitch to NO. Releasing the handswitch will increment the value. Holding the switch in place will continuously increment the value; slowly at first, but more quickly as the switch is held in the NO position. The values can only be increased, so if the desired value is passed, continue holding until the desired value is displayed once again.

Exit the configuration tree at any time by moving the REMOTE/STOP/LOCAL handswitch out of the STOP position; however, changes made during the session will not be retained.

For the values of any parameters that were changed during the session to be retained, the configuration must be cycled through and exited when the "EXIT CONFIG?" message is displayed:

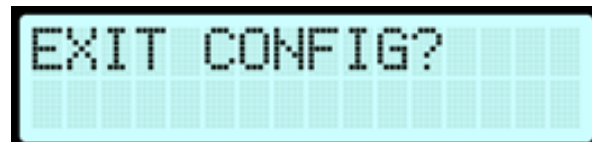

CHANGE LIMITS DETAIL CONFIGURATION MENU

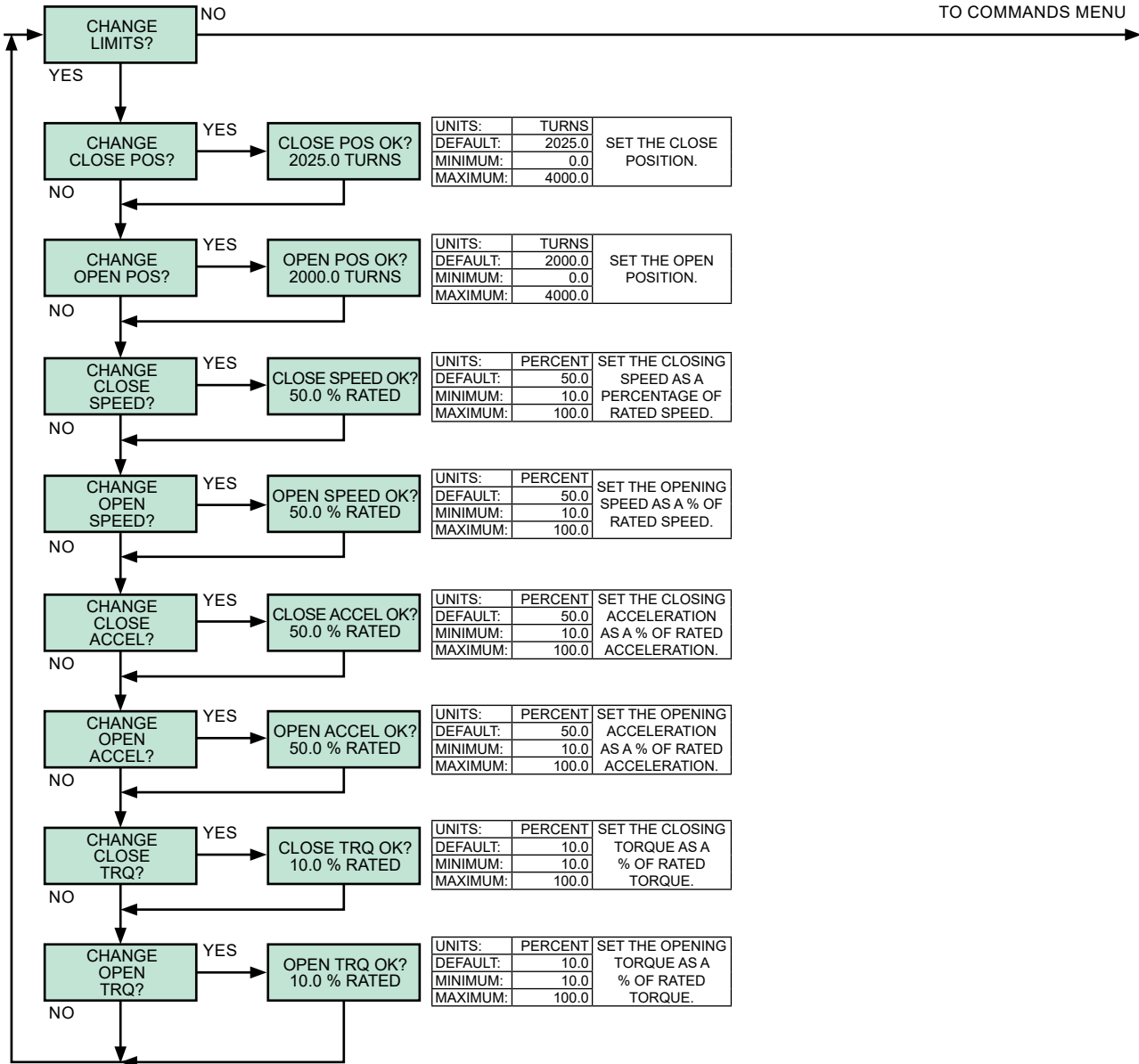

APPENDIX Configuration Menu Details

CHANGE COMMANDS DETAIL CONFIGURATION MENU

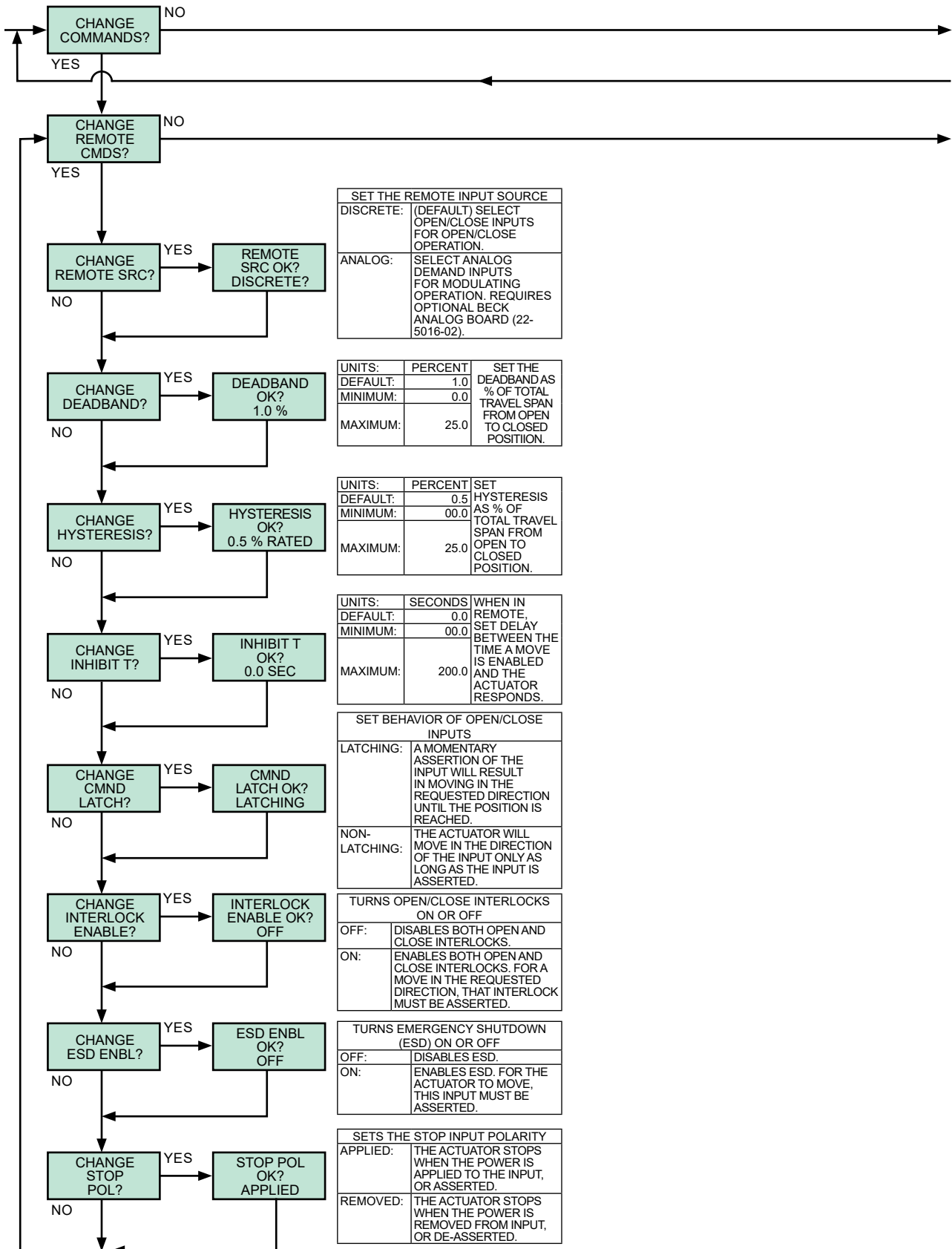

CHANGE COMMANDS DETAIL CONFIGURATION MENU (cont'd)

TO TORQUE MODE MENU

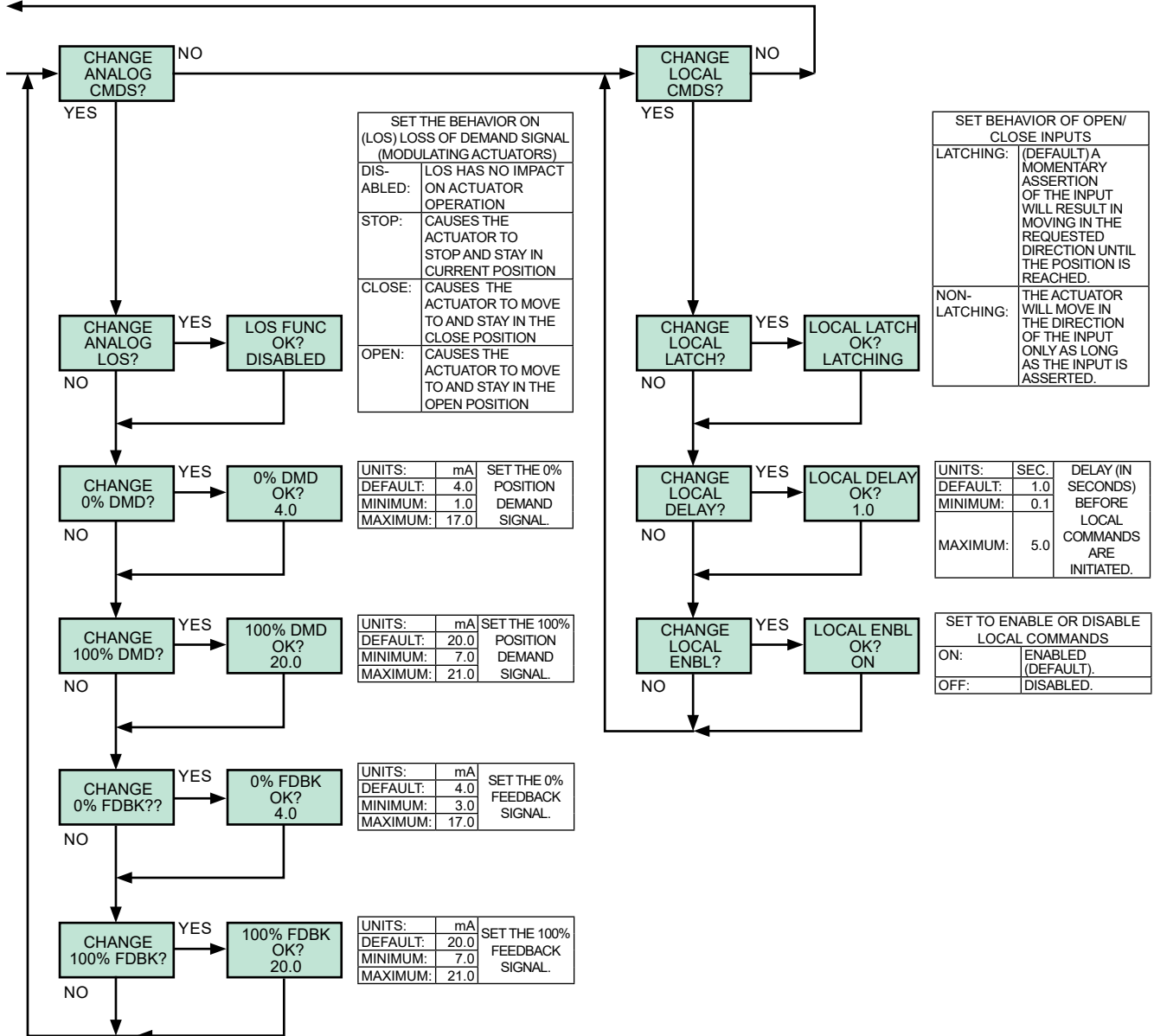

APPENDIX Configuration Menu Details

CHANGE TORQUE MODE DETAIL CONFIGURATION MENU

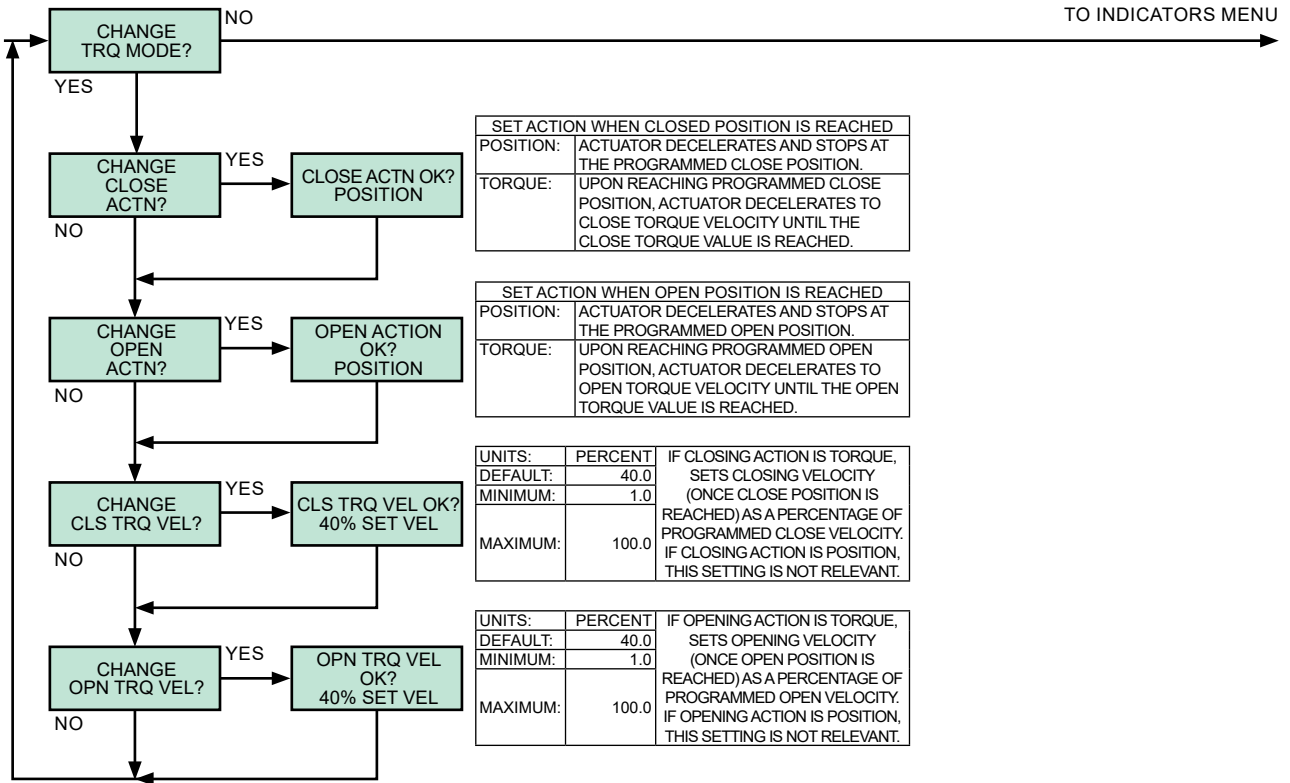

SET ACTION WHEN CLOSED POSITION IS REACHED	
POSITION:	ACTUATOR DECELERATES AND STOPS AT THE PROGRAMMED CLOSE POSITION.
TORQUE:	UPON REACHING PROGRAMMED CLOSE POSITION, ACTUATOR DECELERATES TO CLOSE TORQUE VELOCITY UNTIL THE CLOSE TORQUE VALUE IS REACHED.

SET ACTION WHEN OPEN POSITION IS REACHED	
POSITION:	ACTUATOR DECELERATES AND STOPS AT THE PROGRAMMED OPEN POSITION.
TORQUE:	UPON REACHING PROGRAMMED OPEN POSITION, ACTUATOR DECELERATES TO OPEN TORQUE VELOCITY UNTIL THE OPEN TORQUE VALUE IS REACHED.

UNITS:	PERCENT	IF CLOSING ACTION IS TORQUE, SETS CLOSING VELOCITY (ONCE CLOSE POSITION IS REACHED) AS A PERCENTAGE OF PROGRAMMED CLOSE VELOCITY. IF CLOSING ACTION IS POSITION, THIS SETTING IS NOT RELEVANT.
DEFAULT:	40.0	
MINIMUM:	1.0	
MAXIMUM:	100.0	

UNITS:	PERCENT	IF OPENING ACTION IS TORQUE, SETS OPENING VELOCITY (ONCE OPEN POSITION IS REACHED) AS A PERCENTAGE OF PROGRAMMED OPEN VELOCITY. IF OPENING ACTION IS POSITION, THIS SETTING IS NOT RELEVANT.
DEFAULT:	40.0	
MINIMUM:	1.0	
MAXIMUM:	100.0	

CHANGE INDICATORS DETAIL CONFIGURATION MENU

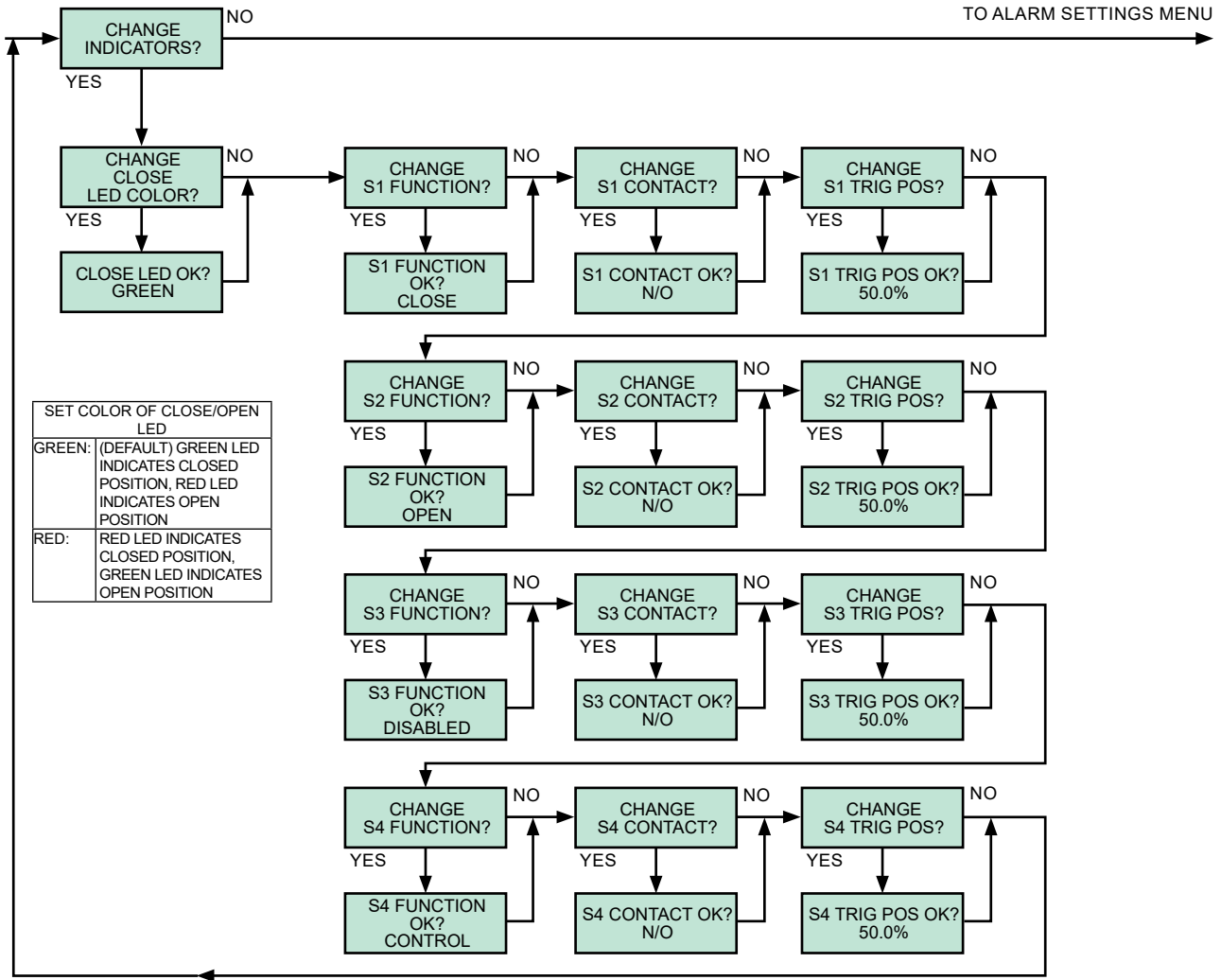

FOR SETTING THE FUNCTION OF ANY RELAY

SET FUNCTION OF RELAY. ALL FOUR RELAYS CAN BE INDEPENDENTLY CONFIGURED TO ANY ONE OF THE FOLLOWING FUNCTIONS:	
DISABLE:	RELAY WILL BE DISABLED AND WILL NOT INDICATE AN INTERNAL STATUS.
CLOSE POSITION:	RELAY WILL BE ASSERTED WHEN THE ACTUATOR IS AT THE CLOSE LIMIT.
OPEN POSITION:	RELAY WILL BE ASSERTED WHEN THE ACTUATOR IS AT THE OPEN LIMIT.
CONTROL MONITOR:	RELAY WILL BE ASSERTED WHEN THE HANDSWITCH IS IN THE REMOTE POSITION AND THERE IS NO ACTUATOR FAULT.
IN REMOTE MODE:	RELAY WILL BE ASSERTED WHEN THE HANDSWITCH IS IN THE REMOTE POSITION.
EITHER OPEN OR CLOSED:	RELAY WILL BE ASSERTED WHEN THE ACTUATOR IS AT EITHER THE OPEN OR CLOSE LIMIT.
MIDTRAVEL:	RELAY WILL BE ASSERTED WHEN THE ACTUATOR IS NOT AT THE OPEN OR CLOSE LIMIT.
ACTUATOR POS> TRIGGER POS	RELAY WILL BE ASSERTED WHEN THE ACTUATOR POSITION IS GREATER THAN THE TRIGGER POSITION.
ACTUATOR POS< TRIGGER POS	RELAY WILL BE ASSERTED WHEN THE ACTUATOR POSITION IS LESS THAN THE TRIGGER POSITION.
MOTOR MOVING. CLOSING:	RELAY WILL BE ASSERTED WHEN THE MOTOR IS RUNNING. RELAY WILL BE ASSERTED WHEN THE ACTUATOR IS MOVING IN THE CLOSE DIRECTION.
OPENING:	RELAY WILL BE ASSERTED WHEN THE ACTUATOR IS MOVING IN THE OPEN DIRECTION.
ACTUATOR FAULT:	RELAY WILL BE ASSERTED WHEN A FAULT EXISTS WITH THE ACTUATOR AND IT CANNOT OPERATE.

FOR SETTING THE CONTACT OF ANY RELAY

SET CONTACT OPERATION OF RELAY.	
N/O:	(DEFAULT) CONTACT IS NORMALLY OPEN. WHEN ASSERTED, THE CONTACT CLOSSES.
N/C:	CONTACT IS NORMALLY CLOSED. WHEN ASSERTED, THE CONTACT OPENS.

FOR SETTING THE TRIGGER POSITION OF ANY RELAY

UNITS:	PERCENT	SETS THE TRIGGER POSITION OF THE RELAY (EXPRESSED IN PERCENTAGE OF TRAVEL). THIS SETTING IS USED IN CONJUNCTION WITH EITHER "ACTUATOR POS > TRIGGER POS" OR "ACTUATOR POS < TRIGGER POS".
DEFAULT:	50.0	
MINIMUM:	0.0	
MAXIMUM:	100.0	

APPENDIX Configuration Menu Details

CHANGE ALARM SETTINGS DETAIL CONFIGURATION MENU

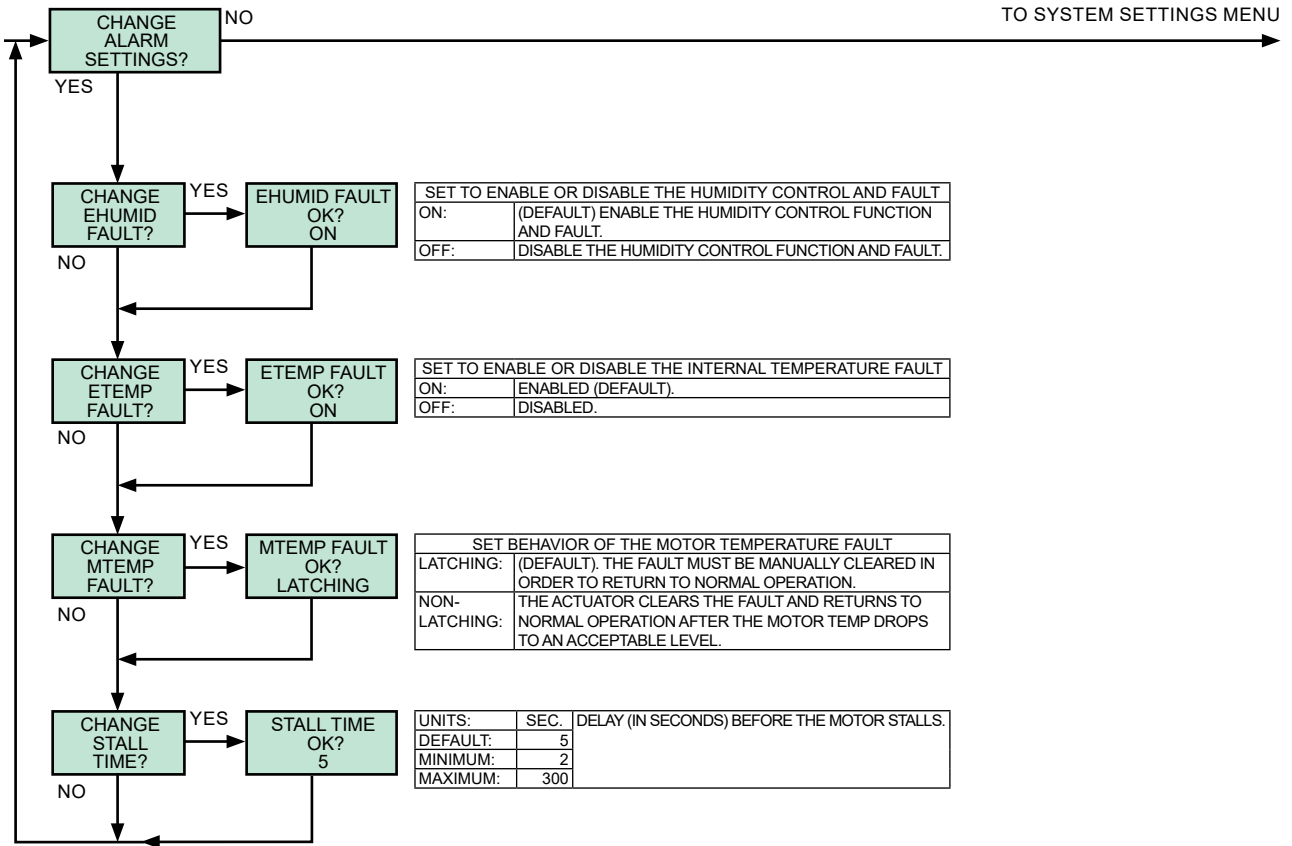

CHANGE SYSTEM SETTINGS DETAIL CONFIGURATION MENU

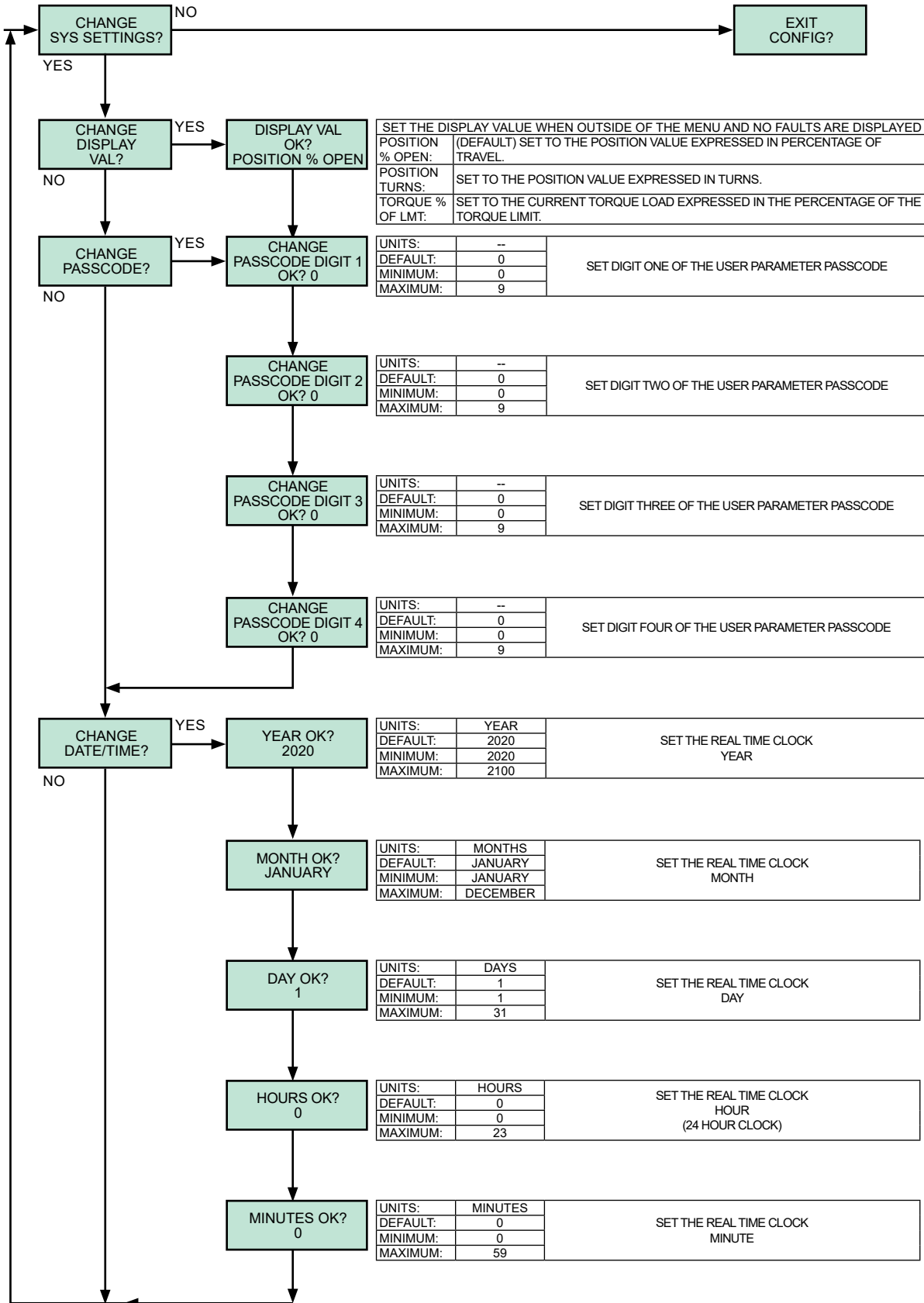

INDEX

Appendices	27–37	Terminal Connections	13
Accessing the configuration menu tree	30	Troubleshooting	23–26
Bluetooth ® App	27	Actuator Configuration	23
Change Commands Detail Configuration Menu	32–33	Display of internally generated faults	23
Change Indicators Detail Configuration Menu	35	Handswitch operation	23
Change Limits Detail Configuration Menu .	31	Inhibit time.....	23
Change System Settings Detail Configuration Menu.....	37	Interlocks.....	23
Change Torque Mode Detail Configuration Menu.....	34	Main voltage and internal power	23
Configuration Menu Tree (abridged)	28–29	Stop.....	23
Configuration Menu Details.....	30–37	Unitized Valve/Actuator Assembly Installation	11
Navigating the Configuration Menu Tree ...	30	Valve Actuator Installations.....	11
Application Reviews	39	Warranty Statement.....	39
Direction of Travel.....	11	Wiring Diagram.....	14
Electrical Installation.....	12		
External Features	5		
Fastener Guide.....	7		
Fuses.....	19		
General Specifications.....	4		
Handswitches	9, 18		
Handwheel.....	9		
How to Obtain Service.....	39		
Introduction.....	2		
LED Status Indicators.....	9		
Mechanical Installation	11		
Modes of Operation	9		
O-Ring (Terminal Compartment)	18		
Outline Dimension Drawings	6–7		
Performance Variables Configuration Procedure	16		
Position Configuration Procedure.....	16		
Power Quality	12		
Quick Configuration Guide	15–17		
Safety Precautions	8		
Site Surveys	39		
Spare Parts.....	22		
Specification Writing	39		
Status Indication Display	10		
Storage Information	8		
Table of Contents.....	3		

SERVICES

SITE SURVEYS

Beck Sales Engineers are available to discuss your process control requirements. Often a visit to your location is the best way to gain a thorough understanding of your needs, in order to meet them most accurately and completely.

Mounting hardware, torque/thrust requirements, control signal information, and optional equipment can be analyzed most effectively at the work site. Beck's analysis at the job site can help ensure that specifications are accurate, especially in the case of complex applications.

APPLICATION REVIEWS

By sharing your needs with a Beck Sales Engineer you can take advantage of the best application advice for the type of control you need. This review will yield a better understanding of the versatility of Beck actuators for your installations, as well as complete details on options and accessories to make the process as effective as possible.

SPECIFICATION WRITING

Beck provides specification writing assistance in order to help you specify and order the right actuators for your applications. Beck Sales Engineers will work with you to make it easier for you to obtain the proper equipment and give you confidence that no details are overlooked.

HOW TO OBTAIN SERVICE

Factory repair of actuators or subassemblies is available for both normal and emergency service. To assure prompt processing, contact the factory to receive a Returned Material Authorization (RMA) number. If a repair estimation is desired, please send the name and phone number of your contact for service authorization. It is helpful to include a description of the work desired with the shipment or, in the event of a problem, the malfunction being experienced.

THREE YEAR LIMITED WARRANTY STATEMENT*

Harold Beck & Sons, Inc. (Beck) warrants that our equipment shall conform to Beck's standard specifications. Beck warrants said equipment to be free from defects in materials and workmanship. This warranty applies to normal recommended use and service for three years from the date on which the equipment is shipped. Improper installation, misuse, improper maintenance, and normal wear and tear are not covered.

The Buyer must notify Beck of any warranty issues within 37 months of original shipment date and return the goods in question, at Buyer's expense, to Beck for evaluation. If the product fails to conform to the warranty, Beck's sole obligation and the Buyer's exclusive remedy will be: 1) the repair or replacement, without charge, at Beck's factory, of any defective equipment covered by this warranty, or 2) at Beck's option, a full refund of the purchase price. In no event will Beck's liability exceed the contract price for the goods claimed to be defective.

THIS WARRANTY IS EXPRESSLY IN LIEU OF ANY OTHER EXPRESS OR IMPLIED WARRANTY, INCLUDING IMPLIED WARRANTIES OF MERCHANTABILITY AND FITNESS FOR A PARTICULAR PURPOSE, AND ALL OTHER OBLIGATIONS OR LIABILITIES OF BECK. In no case shall Beck be liable for any special, incidental or consequential damages based upon breach of warranty, breach of contract, negligence, strict tort, or any other legal theory. Such damages include, but are not limited to, loss of profits, loss of revenue, loss of use of the equipment or any associated equipment, cost of capital, cost of any substitute equipment, facilities or service, downtime, the claims of third parties including customers and injury to property.

Buyer acknowledges its responsibilities under OSHA, related laws and regulations, and other safety laws, regulations, standards, practices or recommendations that are principally directed to the use of equipment in its operating environment. Buyer acknowledges that the conditions under which the equipment will be used, its use or combination with, or proximity to, other equipment, and other circumstances of the operation of such equipment are matters beyond Beck's control. **Buyer hereby agrees to indemnify Beck against all claims, damages, costs or liabilities (including but not limited to, attorney's fees and other legal expenses), whether on account of negligence or otherwise, except those claims based solely upon the negligence of Beck and those claims asserted by Beck's employees which arise out of or result from the operation or use of the equipment by Beck's employees.**

*Note: Internal water damage is not covered by warranty.

A 100% EMPLOYEE OWNED COMPANY

BECK

~ founded 1936 ~

SINCE 2021



HAROLD BECK & SONS, INC.

11 TERRY DRIVE • NEWTOWN, PENNSYLVANIA 18940 • USA

PHONE: 215-968-4600 • FAX: 215-860-6383 • E-MAIL: sales@haroldbeck.com

www.haroldbeck.com

Made in USA

