

BECK[®]

INSTRUCTION MANUAL



ELECTRIC ACTUATORS FOR INDUSTRIAL PROCESS CONTROL

INTRODUCTION

This manual contains the information needed to install, operate and maintain Beck model 75-106, -105 & -103 compact rotary actuators, manufactured by Harold Beck & Sons, Inc. of Newtown, Pennsylvania.

The Group 75 actuator is ideal for the space-restricted hot environments typical of boiler windbox applications and other devices requiring up to 80 lb-ft (108 N•m) of torque. It is also well-suited to small rotary valve applications in tight spaces.

IMPORTANT: This manual contains information that will make installation simple, efficient and trouble-free. Please read and understand the appropriate sections in this manual before attempting to install or operate your actuator.



Group 11 rotary actuators ... provide precise position control of dampers, quarter-turn valves, fluid couplings, and other devices requiring up to 1,800 lb-ft (2 440 N•m) actuator torque.



Group 22 digital control actuators ... are designed for accurate, reliable, modulating, digital control of high torque applications. The actuator is ideal for use in large boiler applications, such as ID/FD fan dampers.



Group 29 linear valve actuators ... are ideally suited for globe valves from 1" to 8" (25 mm to 203 mm) diameter. Beck's unique "Tight-Seater™" coupling provides positive seating of valves.



Group 31 compact rotary actuators ... are particularly suited for coupling to ball, plug, and butterfly valves up to 4" (102 mm) diameter, and small dampers.

TABLE OF CONTENTS

Introduction	2
General Specifications	4
Outline Dimension Drawings	6
Actuator Options	8
Precautionary Information	10
Installation	11
Mechanical	11
Electrical	15
Wiring	16
Operation	18
Start-up	19
Configuration/Calibration	20
Calibration	22
Direction Change	22
Feedback Signal	23
Maintenance	26
Troubleshooting	37
Index	38
Services	39

GENERAL SPECIFICATIONS

Actuator Power	120 V ac, single-phase, 60 Hz (Standard), 50 Hz (Optional)	Allowable Tolerance	+10% -15%
----------------	--	---------------------	--------------

Operating Conditions	-20° to 85°C (-4° to 185°F) - Standard. -20° to 120°C (-4° to 248°F) - Optional (High Temperature). 0 to 100% relative humidity, non-condensing.
Feedback Signal with Contactless Position Sensor (CPS-4)	4–20 mA
Output Stability	0.25% of span from 102 to 132 V ac ±0.03% of span/°C for 0 to 50°C, ±0.05% of span/°C for -40° to 85°C
Linearity	±1% of span, max. independent error
Hysteresis	0.25% of span at any point
Isolation	Max. leakage of 10 µA at 60 V rms, 60 Hz from output to ground
Film Potentiometer	1,000 ohms
Max. Voltage	40 V
Wattage	2 W max.
Linearity	±0.5%
Max. Wiper Current	1 mA
Action on Loss of Power	Stays in place.
Limit Switches	Two SPDT, one for CW and one for CCW limit of travel. Actuators having position sensing capability (Options 6 & 5), have over-travel limit switches set 1/2° outside the CW and CCW travel range (typically, -0.5° and 100.5°). Actuators without position sensing (Option 3), have end-of-travel limit switches set at the CW and CCW travel range (typically, 0° and 100°).
Auxiliary Switches	Up to four 3 A, 120 V ac switches available (.5 A @ 125 V dc, .25 A @ 250 V dc). See page 21 for switch setting diagram.
Handswitch	Permits local electrical operation, independent of controller signal. Standard on all units. An auxiliary contact is available as an option for remote auto indication (rated 3 A at 120 V ac).
Handwheel	Provides manual operation without electrical power.

Motor Assembly	120 V ac, single-phase, no-burnout, non-coasting motor has instant magnetic braking. Requires no contacts or moving parts.
Gear Train	High-efficiency, precision-cut, heat-treated alloy steel and ductile iron spur gears.
Mechanical Stops	Prevent overtravel during operation.
Enclosure	Precision-machined, aluminum alloy castings painted with corrosion-resistant polyurethane paint, provide a rugged, dust-tight, weatherproof enclosure. Type 4X; IP68, 3 meters/48 hours*. *Internal water damage is not covered by warranty.
Maximum Output Shaft Rotation	100°.
Mounting Orientation	Any orientation—no limitations.

*For more information or to inquire about details not specifically listed, please call Beck at 215-968-4600.

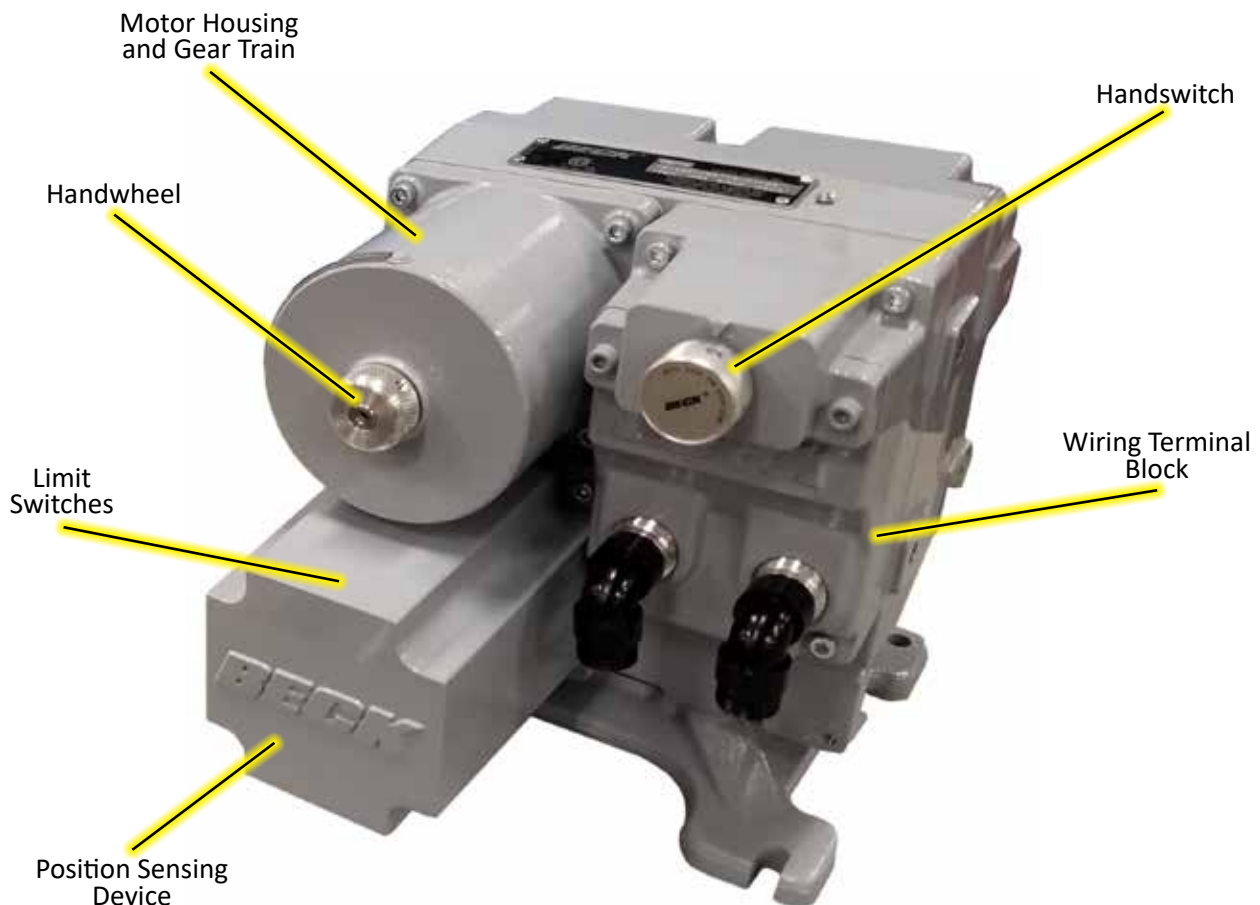

MODEL 75-10_ COMPONENTS

OUTLINE DIMENSION DRAWINGS

NOTE: All dimensions appear in inches and [mm] and are subject to change without notice.

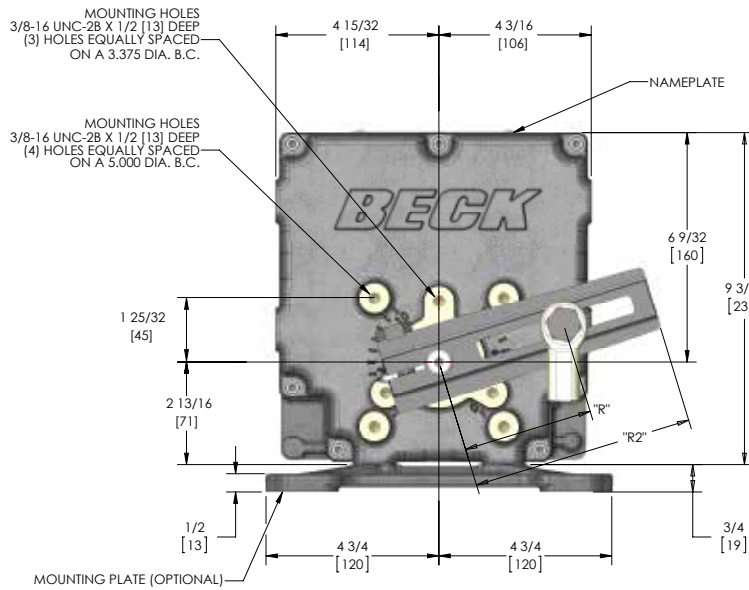

FRONT VIEW

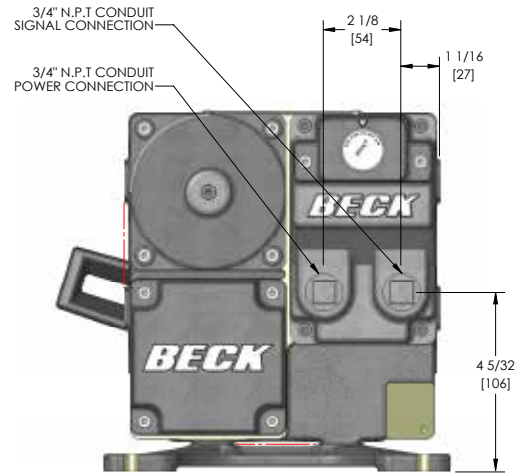

REAR VIEW

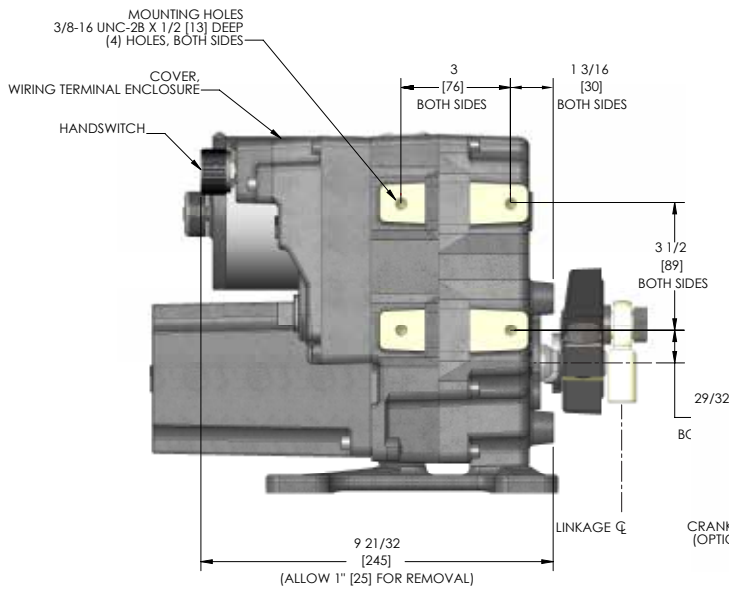

SIDE VIEWS

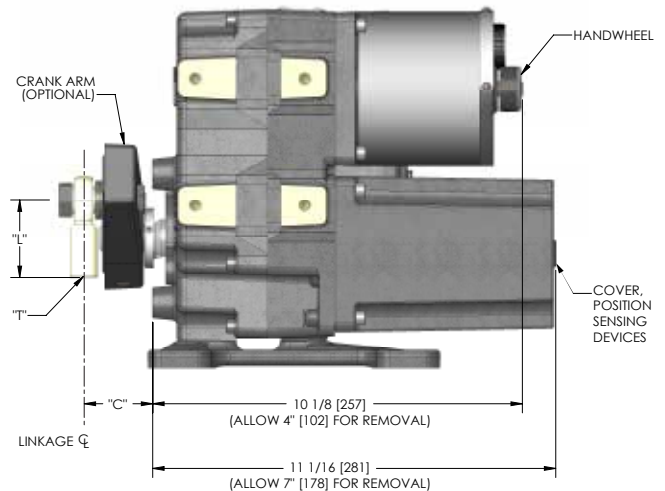

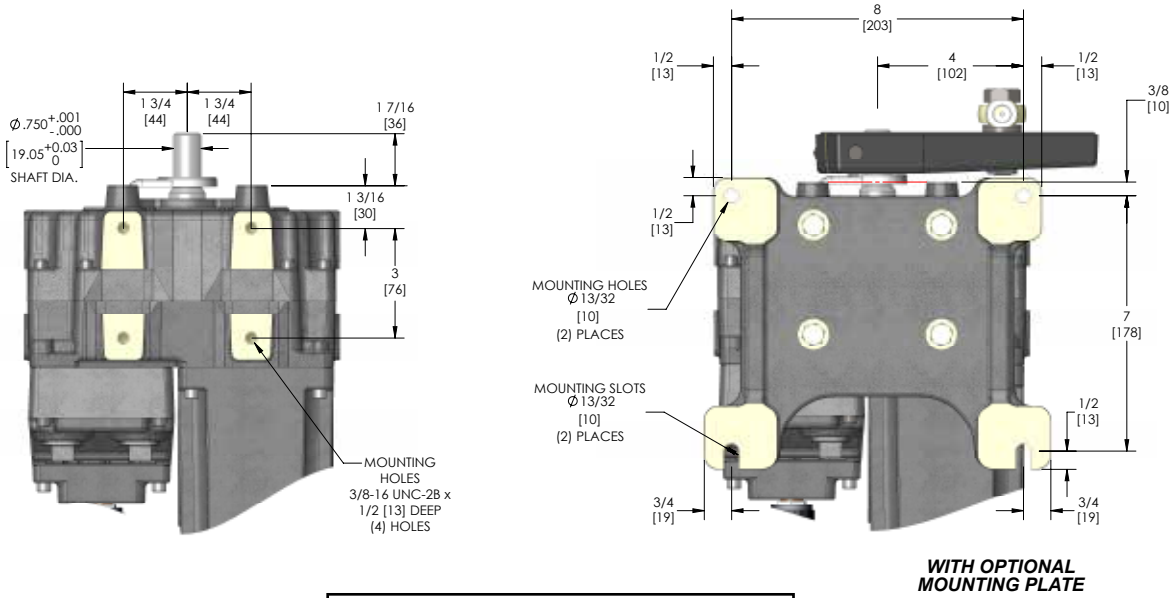

BOTTOM MOUNTING LOCATIONS

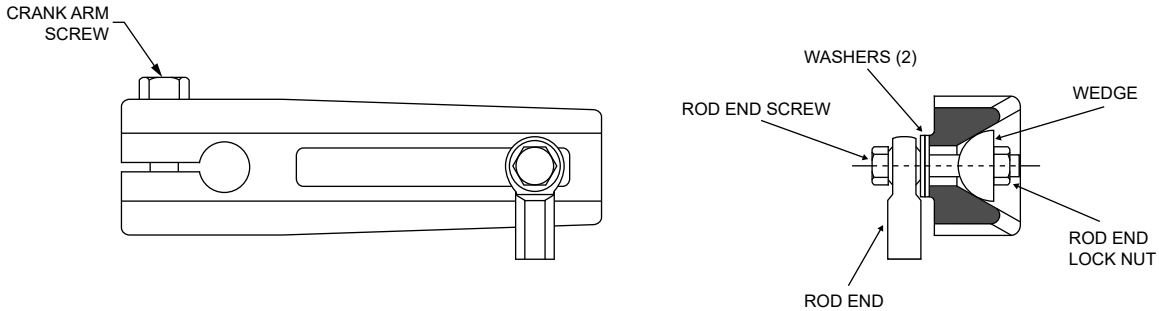

OPTIONAL CRANK ARM DETAIL (Crank Arm 10-3491-05 shown)

MODEL INFORMATION

Max. Torque (lb-ft)[N·m]	Optional Crank Arm and Rod End						Output Shaft Dia. (in)[mm]	Approx. Weight (lbs)[kgs]	Maximum Overhung Load (lbs)[kgs]
	Crank Arm Part No.	Crank Arm Radius (adj.) "R" (in)[mm]	Crank Arm Radius "R2" (in)[mm]	Linkage Center to Front Mtg. Bosses "C" (in)[mm]	Rod End Length "L" (in)[mm]	Rod End Internal Thread "T" (in)[mm]			
80 [108]	10-3491-05	1 1/2-5 1/8 [38-130]	6 3/32 [155]	1 27/32-1 7/8 [47-48]	2 1/8 [54]	1/2-20 x 1 3/16 [30]	3/4 [19]	46 [21]	750 [340]
80 [108]	10-3491-52	1 1/2-4 [38-102]	4 11/16 [119]	1 21/32-1 15/16 [42-49]	2 1/8 [54]	1/2-20 x 1 3/16 [30]	3/4 [19]	46 [21]	750 [340]
40 [54]	10-3492-02	1 1/2-5 1/8 [38-130]	5 11/16 [144]	1 11/32-1 3/4 [34-44]	1 3/8 [35]	5/16-24 x 3/4 [19]	3/4 [19]	46 [21]	500 [227]

RECOMMENDED SCREW TORQUES

	Screw Size (in)	Wrench Size (in)	Torque (lb-ft)[N·m]
Cover Screw	1/4-20	3/16	6 [8]
Motor Screw	1/4-20	3/16	6 [8]
Mounting Plate (Optional) Screw	3/8-16	9/16	20 [27]

Crank Arm Part No.	Crank Arm Screw Size (in)	Torque (lb-ft)[N·m]	Rod End Screw Size (in)	Torque (lb-ft)[N·m]	Rod End Lock Nut Size (in)	Torque (lb-ft)[N·m]	Wrench Size (in)
10-3491-05	1/2-13	75 [102]	1/2-13	35 [47]*	1/2-13	35 [47]*	3/4
10-3491-52	3/8-24	50 [68]*	1/2-13	35 [47]*	1/2-13	35 [47]*	9/16 & 3/4
10-3492-02	5/16-24	20 [27]	5/16-24	20 [27]*	5/16-24	20 [27]*	1/2

*Apply 90% of specified torque when optional Stainless Steel fasteners are used.

ACTUATOR OPTIONS

COMMON GROUP 75 OPTIONS (BY MODEL NO.)

Model No.	Operating Temp. Range	Power/Freq.(V/Hz), Torque (lb-ft [N•m]), Timing (sec./100°)	Feedback Device	Terminal Enclosure	DPDT Relay w/ Input/Output Terminals
75-103	-20° to 85°C. or -20° to 120°C.	120/60, 40[54], 40 or 120/50, 40[54], 48 or	None	Din Rail or Electronic	Available with Electronic Enclosure Only
75-105		120/60, 80[108], 40 or 120/50, 80[108], 48 or	1,000Ω Film Pot.		
75-106		120/60, 80[108], 24 or 120/50, 80[108], 28.8	CPS-4 2-Wire		

Model No.	Remotely Mounted Electronics	Auxiliary Switches	Handswitch	Crank Arm Assy. Adj. Radius (in.[mm]), Rod End	Index Pointer	Actuator Mounting Plate
75-103	Available	0, 2 or 4	With or Without	1½-5⅛ [38-130], 1/2-20 1½-5⅛ [38-130], 5/16-24 1½-4 [38-102], 1/2-20	Available	Available
75-105						
75-106						

COMMON GROUP 75 OPTIONS

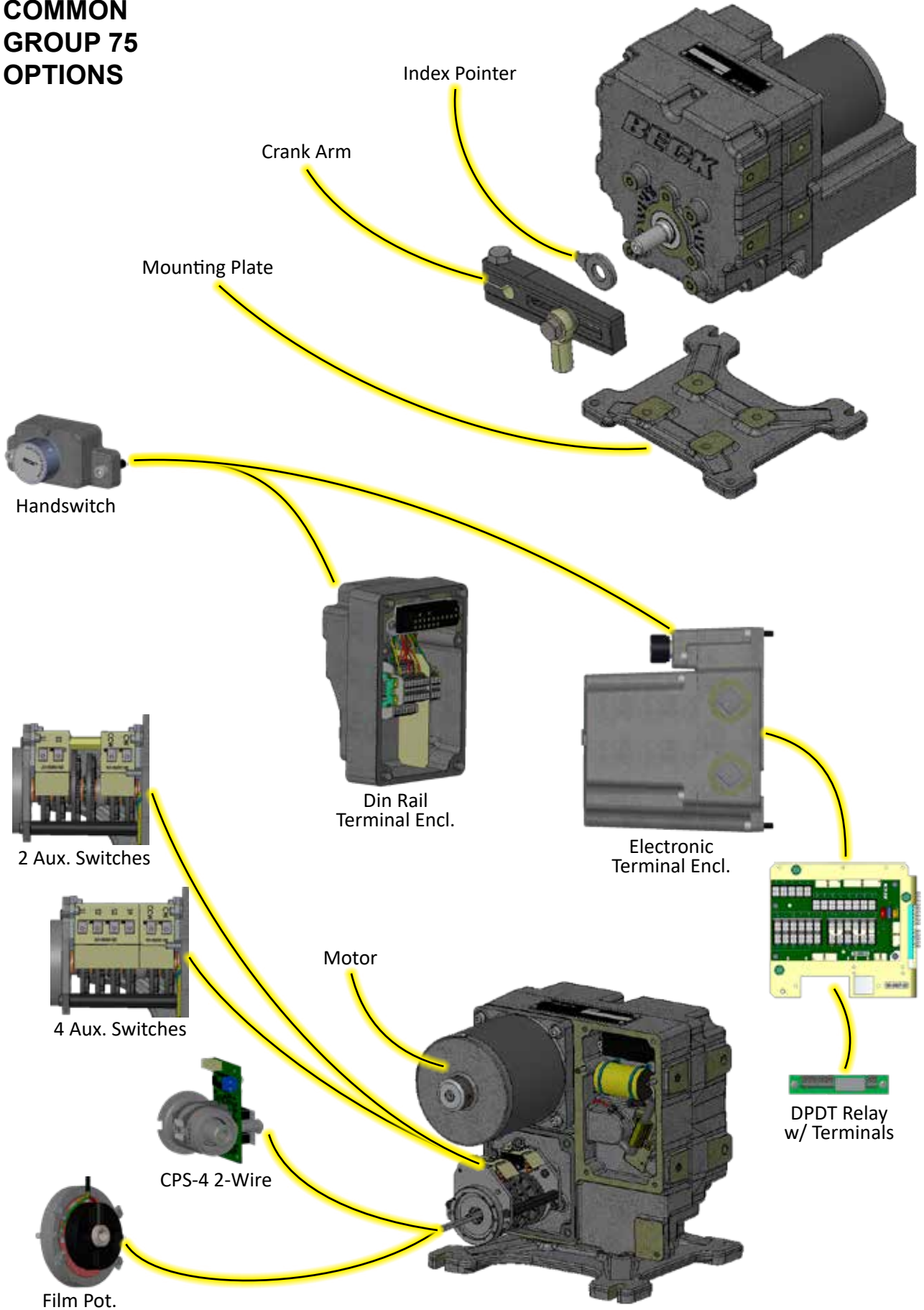

PRECAUTIONARY INFORMATION

SAFETY PRECAUTIONS



WARNING

Installation and service instructions are for use by qualified personnel only. To avoid injury and electric shock, do not perform any servicing other than that contained in this manual. Please read and understand the appropriate sections in this manual before attempting to install or operate your actuator.

STORAGE INFORMATION

Beck actuators should be stored in a clean, dry area. Damage due to moisture while in storage is not covered by warranty.

INSTALLATION—MECHANICAL

There are many considerations regarding proper mechanical installation—see the instructions beginning on page 11 for details. Refer to the outline dimension drawings for physical dimensions and required clearances.

VALVE ACTUATOR INSTALLATIONS



CAUTION

Working with valves installed in a pipeline can be dangerous. Take appropriate precautions when mounting to installed valves.

INSTALLATION—ELECTRICAL

See the instructions beginning on page 15 for details regarding electrical installation.



CAUTION

For maximum safety, the Beck actuator body should be grounded. Use the green grounding screw in the wiring compartment of the actuator.



CAUTION

Always close covers immediately after installation or service to prevent moisture or other foreign matter from entering the actuator.

CONDUIT ENTRIES

Conduits are provided for power and signal wiring. Temporary plugs are installed in the conduit entrances at the factory for shipping only and are not intended for permanent use. Prior to actuator operation, all conduit entrances must be properly sealed in accordance with National Standards or Regulatory Authorities.

INSTALLATION Mechanical

ACTUATOR MOUNTING

Actuators may be mounted in any orientation. If mounting near obstructions such as pipes or beams, take into consideration access to the field wiring terminals, enclosure cover clearances, and the output shaft. Refer to the outline dimension drawings beginning on page 6 for the clearance necessary to remove covers.

When the actuator is bolted to a mounting plate, the plate must be rigid and must not yield to the stresses created from operating the actuator. If the mounting plate is not rigid or the mounting bolts are not sufficiently tightened, damage to the actuator housing could result. A rigid, vibration-free surface will generally prolong the life of the actuator's components. The mounting plate should be at least as thick as the diameter of the mounting bolts. An optional mounting plate is available from Beck.

Mounting bolts should be hex head steel, zinc plated (HHSZP) Grade 2 or better, 3/8"-16 and torqued to 20 lb-ft (27 N•m).

UNITIZED VALVE/ACTUATOR ASSEMBLY INSTALLATION

Inspect the valve and pipe flanges to ensure they are clean. Mount the assembly according to the valve manufacturer's instruction.

INSTALLING LINKAGE-CONNECTED ACTUATORS

When installing a Beck actuator in a location remote from the driven device, be sure it is firmly bolted to a flat mounting surface that will not yield to the stresses created from operating the device. A rigid, vibration-free surface will generally prolong the life of the actuator's components.

The output shaft of the actuator should be parallel to the damper or valve shaft. A crank arm is installed on the Beck output shaft. A lever arm should be installed on the driven shaft parallel to the crank arm at mid-stroke and perpendicular to the line between the two shaft centers. The linkage connecting the two arms should also be parallel to the line between the shaft centers. See the illustration at right.

A linkage connection between the crank arm and lever arm should be established. Small misalignments can be tolerated if a rod end fitting is used on the driven lever similar to that on the Beck crank arm. The actuator's crank arm can be positioned at any angle on the shaft.

Beck linkage kits are available for convenient field installation (see page 13).

DESIGN THE INSTALLATION

Select a suitable mounting location that will allow for the following:

1. Clearance to remove the actuator covers.
2. A mounting base height to allow easy access and, if desired, full 360° crank arm rotation.
3. The linkage to move through its full travel without interference.
4. The actuator crank arm and damper lever arm to rotate in the same plane and the same direction.
5. The wiring conduits to be run from below the actuator to help prevent water entry.

INSTALLATION Mechanical

LINKAGE REQUIREMENTS

(IF APPLICABLE)

For best results, the linkage should be designed in advance. In most applications, the best control will result when the linkage is adjusted so that the full 100° travel of the Beck actuator shaft is used, even though the driven lever may travel less than 100°. The general requirements for a good linkage are:

1. It must be rigid enough to carry the link thrust without bending or deforming.
2. It must have a built-in means of adjustment so that the length of the connecting link can be changed a small amount.
3. Rod end bearings, similar to those furnished on the Beck crank arm, should be used at both ends of the connecting link. This type of device permits small angular misalignments and helps prevent binding of the linkage.
4. The Beck crank arm radius must be calculated so that the arm will move through a 100° arc and the driven lever will move through its correct arc.
5. The actuator and driven shafts must be parallel and the linkage should be in a plane perpendicular to the shafts. See the example of a parallel linkage arrangement at right. Z-Linkage arrangements (where linkage ends are on opposite sides of the parallel between the driven shaft and actuator output shaft) are **not** recommended.

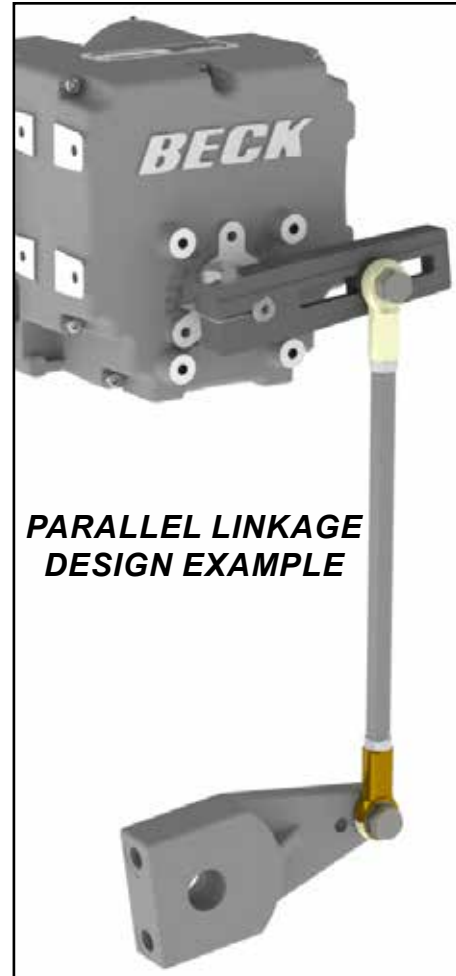

LINKAGE KITS AVAILABLE

Beck linkage kits are made to accommodate a wide variation in linkage lengths without requiring modification of end fittings. Linkage kits are also available in stainless steel for use in corrosive environments.

Hex Linkage kits are available for applications with linkage length requirements between 9" (229 mm) and 26" (660 mm). Each hex linkage kit comes complete with a rod end, studs, threaded hex bar, and jam nut hardware.

To order hex linkage kits, first obtain the approximate overall linkage length "A" in the hex linkage figure above. Select the kit part number from the table at right. For lengths beyond those listed in the table, contact your Beck sales engineer.

Pipe linkage kits are available for longer linkage length requirements and include the essential linkage end connections, rod end, studs, and jam nut hardware. Schedule 40 pipe is not included and must be cut to length and threaded in the field (see table above, for instructions to calculate pipe length). To simplify installation of the pipe link, the kit accepts NPT right-hand threads on both ends of the pipe. Left-hand threads are internal to the linkage kit assembly, making final length adjustments quick and easy.

To order pipe linkage kits, first obtain the approximate overall linkage length "A" in the figure above. Select the kit part number from the table at right. For lengths beyond those listed in the table, contact your Beck sales engineer.

LINK-ASSIST™ REPORT

The Beck Link-Assist™ computer program optimizes the linkage configuration for the application load. It ensures proper setup and operation of the actuator. Contact your Beck Sales Engineer to take advantage of Beck's Link-Assist™ program. Additional Link-Assist™ information is available on the Beck website: www.haroldbeck.com.

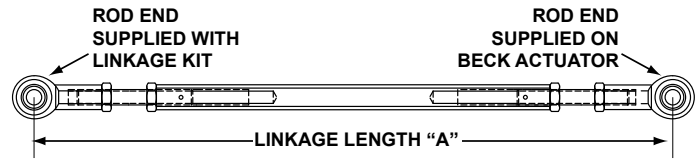

HEX LINKAGE KITS

Linkage Length	Linkage Kit Part No.	Stainless Steel Linkage Kit Part No.	Hex Size	Rod End Thread
9-11.5" (229-292 mm)	14-8300-22	14-8300-64	5/8" [15.88]	1/2-20 UNF
10.5-14.5" (269-371 mm)	14-8300-32	14-8300-72		
14.5-18.5" (368-470 mm)	14-8300-04	14-8300-48		
18-22" (457-559 mm)	14-8300-06	14-8300-50		
22-26" (559-660 mm)	14-8300-16	14-8300-58		

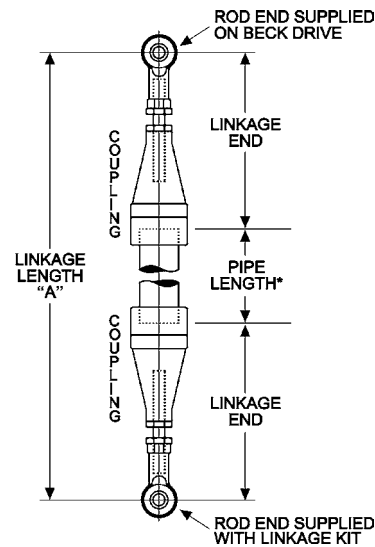

PIPE LINKAGE KITS

Linkage Length	Linkage Kit Part No.	Stainless Steel Linkage Kit Part No.	Pipe Size	Rod End Thread	Length of 2 Linkage Ends (+/- 1.5" (38 mm))
22-84" (559-2 134 mm)	20-1730-05	20-1730-15	1" (25 mm)	1/2-20 UNF	20 1/2" (521 mm)
31-120" (787-3 048 mm)	20-1740-06	20-1740-16	1.5" (38 mm)		29 1/4" (743 mm)

*NOTE: To calculate length of pipe required, subtract "Length of 2 Linkage Ends" (shown in table above) from Linkage Length "A" (shown in diagram above).

INSTALLATION Mechanical

LINKAGE INSTALLATION

The following procedure is recommended to couple the linkage between the Beck Group 75 actuator and the driven shaft:

1. Position the driven shaft ❶ to the fully closed position.
2. Set the driven shaft lever to its required starting angle ❷ (predetermined with Link-Assist™).
3. Remove the rod end ❸ from the Beck crank arm. Attach to the connecting link.
4. Adjust the connecting link ❹ to the predetermined length.
5. Connect the connecting link to the driven lever at the predetermined radius ❺.
6. Reattach the rod end ❻ to the Beck crank arm at the predetermined radius. Tighten the rod end screw to the appropriate torque (see page 7).
7. Loosen the crank arm screw ❼.



CAUTION

The crank arm will pop free, allowing adjustment for 360° around the shaft.

8. Position the actuator's output shaft ❸ to its fully closed limit.
9. Swing the crank arm into position ❹.
10. Tighten the crank arm screw ❿ to the appropriate torque (see page 7).
11. Lubricate the rod end bearings.

Carefully move the actuator's output shaft to the fully open (maximum input signal) position. Check that no binding occurs between the linkage, crank arm, driven shaft lever, and surrounding obstructions. Also observe that the driven shaft rotates the proper amount. Ensure that the actuator reaches the proper limit and shuts off.

If binding in the linkage occurs due to too much travel of the driven lever, travel can be reduced by shortening the Beck actuator crank arm radius (return to Step 5 above and repeat adjustments).

To adjust the linkage length, alter the thread engagement in the stud couplings. The couplings have right- and left-hand threads, so it is not necessary to disconnect the ends to make a length adjustment. The stud threads must be engaged at least 1.25 diameters deep into the rod ends. Make adjustments by altering thread engagement in the couplings only. Be careful not to expose more than 7" (178 mm) of stud between the rod end and coupling.

LINKAGE INSTALLATION

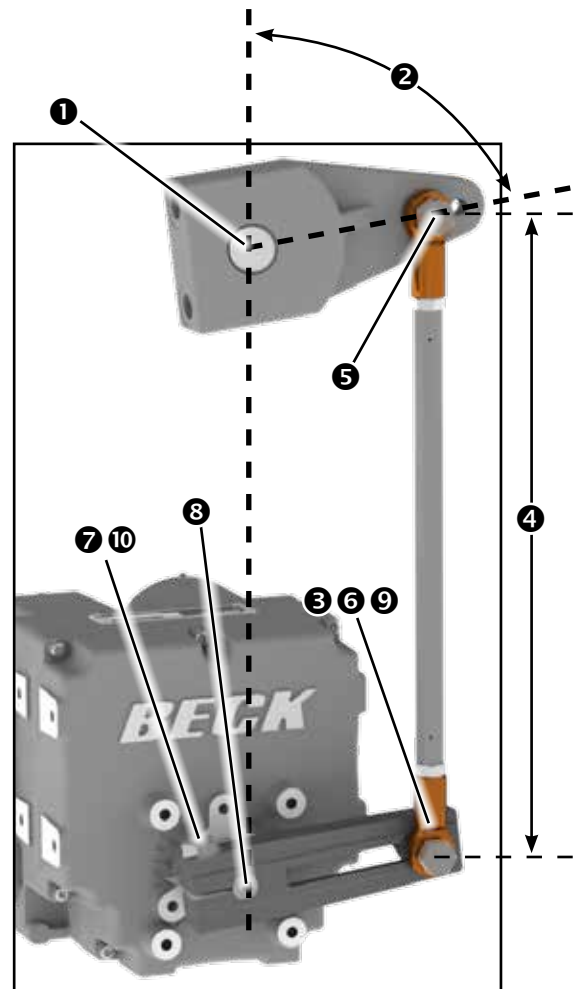

CAUTION

The thread engagement depth in the couplings and rod ends must be greater than 1.25 x the thread diameter.

Once again, check operation to confirm that no binding occurs between the linkage and crank arm, driven lever arm, or surrounding obstructions. If necessary, further travel adjustments can be made by repeating the above steps.

Ensure that the lock nut and screw are tightened to the proper torque (see Outline Dimension Drawings, page 7).

Do not change limit switch settings to obtain desired valve or damper travel; this will adversely affect actuator operation.

INSTALLATION Electrical

POWER QUALITY

Power quality disturbances such as power outages, transient voltages, harmonic distortions, and electrical noise will adversely affect your actuator performance. Protecting your actuator from these conditions can reduce downtime and promote longer life for the equipment. Following the industry accepted standards below will help protect your actuator.

- ✦ Select wiring materials according to the correct ampacity ratings dictated by national and local regulations.
- ✦ Shielded, twisted pair cables can be used for signal connections to avoid being affected by electrical noise. These signal wires, based on Noise Susceptibility Level (NSL) per IEEE-518, fall into the level 1 classification. A braided shield will be more effective than a wrapped foil shield. Signal wire shields should be connected to the actuator casting grounding screw. If grounding at the signal source is required, then the shield should not be grounded at the actuator.
- ✦ Raceways such as conduits and trays must be grounded at both ends to properly meet immunity requirements.
- ✦ An AC power ground connection should be made between the power source and the Beck actuator. Grounding connections including wire and metal conduit are permitted, but the actuator-grounding conductor may not be connected to a structured metal frame of a building.
- ✦ Surge suppression equipment that meets Underwriters Laboratory (UL) Standard 1449 may be used to protect against transient voltage conditions.
- ✦ Power Conditioners may be used to regulate the supply voltage and maintain a constant voltage level. They are helpful in protection against voltage sags and swells, as well as some measure of electrical noise protection.
- ✦ Harmonic filters may be used to minimize the effects of supply voltage waveform distortions and are used in applications that incur a large amount of high-frequency electronic noise.



CAUTION

Always close covers immediately after installation or service to prevent moisture or other foreign matter from entering the actuator.

ELECTRICAL INSTALLATION

WIRING DETAILS

Terminal Enclosure Type	Terminal Wire Size Range Required AWG (mm ²)	Terminal Screw Torque lb-in (N•m)	Ground Terminal Wire Size Range Required AWG (mm ²)	Ground Terminal Screw Torque lb-in (N•m)
Electronic	#22–12 (.33–3.31)	5 (0.6)	n/a	13 (1.5)
Din Rail	#26–14 (.13–2.08)	3 (0.3)	#24–12 (.20–3.31)	3 (0.3)

Two N.P.T. conduit connections are provided for power and signal wiring to the actuator. As viewed from the rear, the conduit to the left (closest to the motor—see the Outline Dimension, page 6) is provided for power and auxiliary switch connections, and the conduit to the right is provided for signal wiring connections (both conduits are 3/4"). Conduits should be routed from below the actuator so that condensation and other contaminants flow away from the conduit. All conduit entrances must be properly sealed in accordance with National Standards or Regulatory Authorities.

Power and signal wires should be routed to the actuator separately and be either shielded cables or installed in conductive conduit and/or cable trays.

Refer to the wiring diagram furnished with your Beck actuator for proper power and signal connections. The customer must supply 120 V ac to power the actuator. The 120 V ac line connects to terminal 1 and neutral to terminal 2.

For model 75-106, the customer must supply power to the 2-wire CPS-4 (as shown in the wiring diagram).

It is advisable to provide normal short circuit protection on the AC power line. A copy of the wiring diagram may be found inside the terminal compartment or may be obtained from Beck by providing the Serial number of your actuator.

For maximum safety, the Beck actuator body should be grounded. Use the green grounding screw in the wiring compartment of the actuator.

INSTALLATION Wiring

TERMINAL CONNECTIONS

Each Beck actuator is custom built to match the control requirements of your system (specified at the time of order). Each actuator has a specific wiring diagram located in the terminal compartment. Typical wiring connections are shown below.

Each actuator can be ordered with up to four optional auxiliary switches. Wiring connections for these are described on the following pages.

TYPICAL WIRING CONNECTIONS

(Each actuator has a specific wiring diagram located in the terminal compartment)

Option 6, Modulating Direct AC Control with Contactless Position Sensor (CPS-4)

Customer must supply three wires to directly control the actuator motor direction: One 120 V ac line to run CW (terminal 12), one 120 V ac line to run CCW (terminal 16), and one neutral (terminal 2). Customer must supply two additional wires (12–24 V dc) to power the “2-wire” type CPS-4 (see your specific wiring diagram or the typical wiring diagram below).

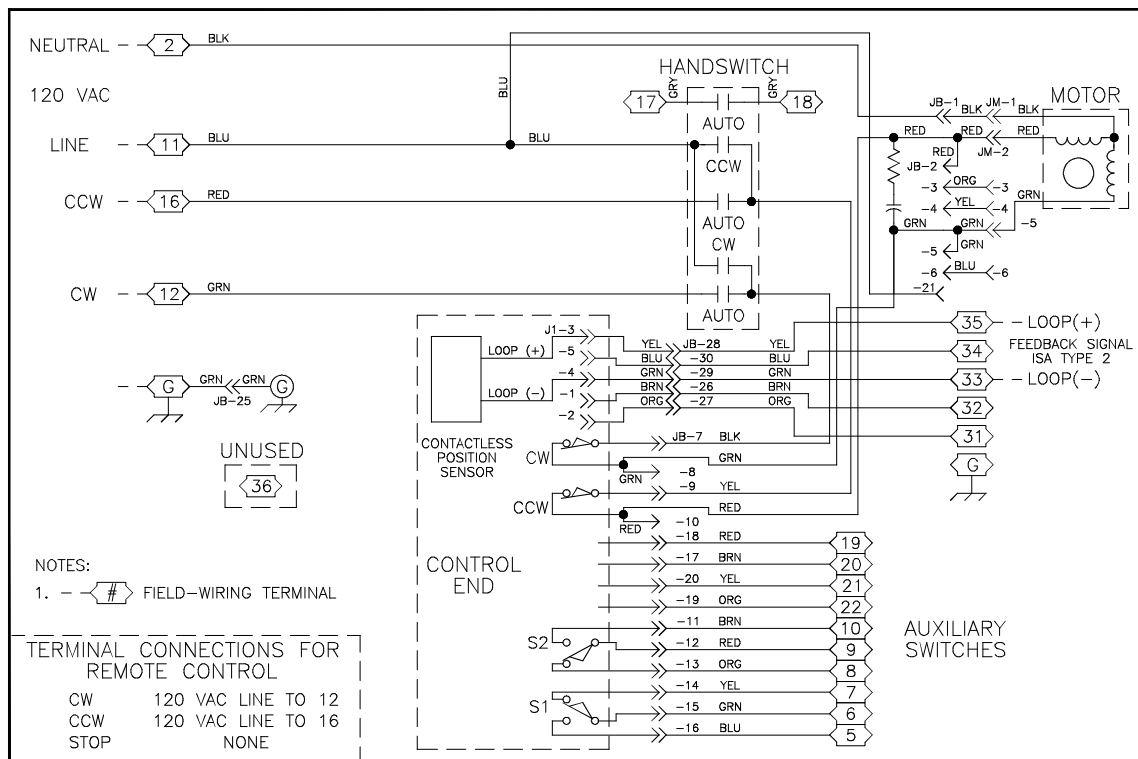

Option 5, Modulating *Direct AC Control with Potentiometer Position Sensing*

Customer must supply three wires to directly control the actuator motor direction: One 120 V ac line to run CW (terminal 12), one 120 V ac line to run CCW (terminal 16), and one neutral (terminal 2). The position feedback potentiometer connections are available at terminals 32 (CW), 33 (wiper), and 34 (CCW).

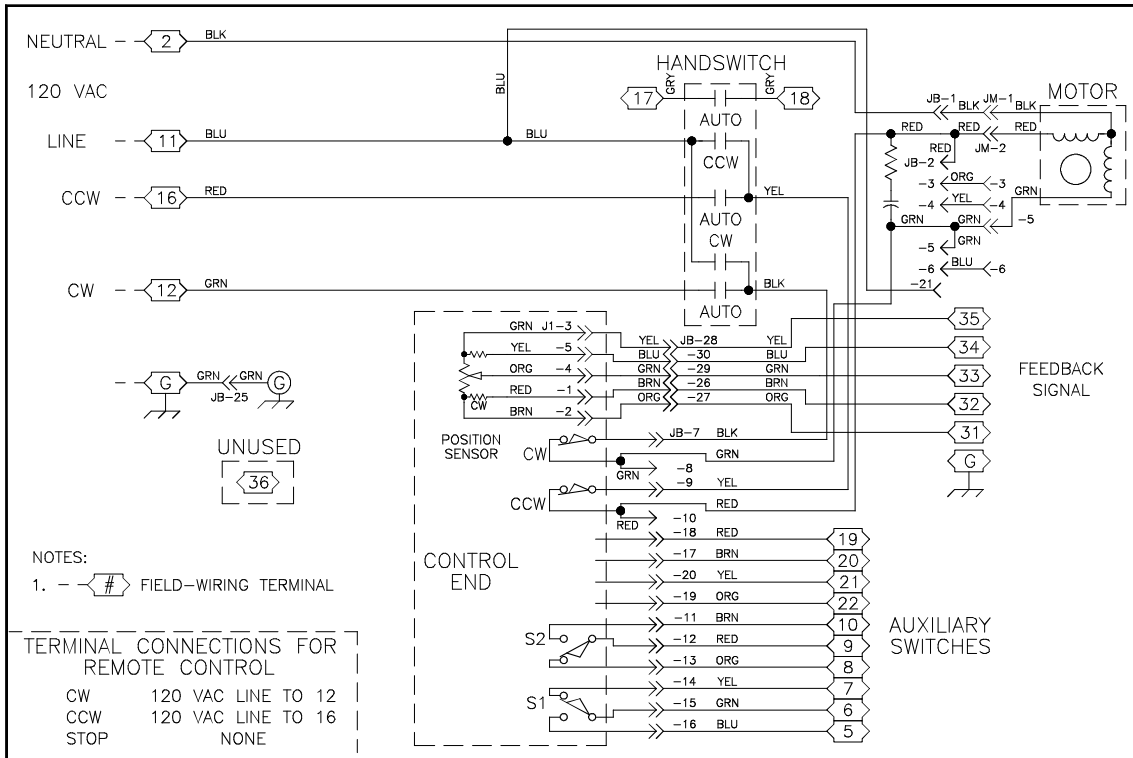

Option 3, Open / Close *Direct AC Control*

Customer must supply three wires to directly control the actuator motor direction: One 120 V ac line to run CW (terminal 12), one 120 V ac line to run CCW (terminal 16), and one neutral (terminal 2).

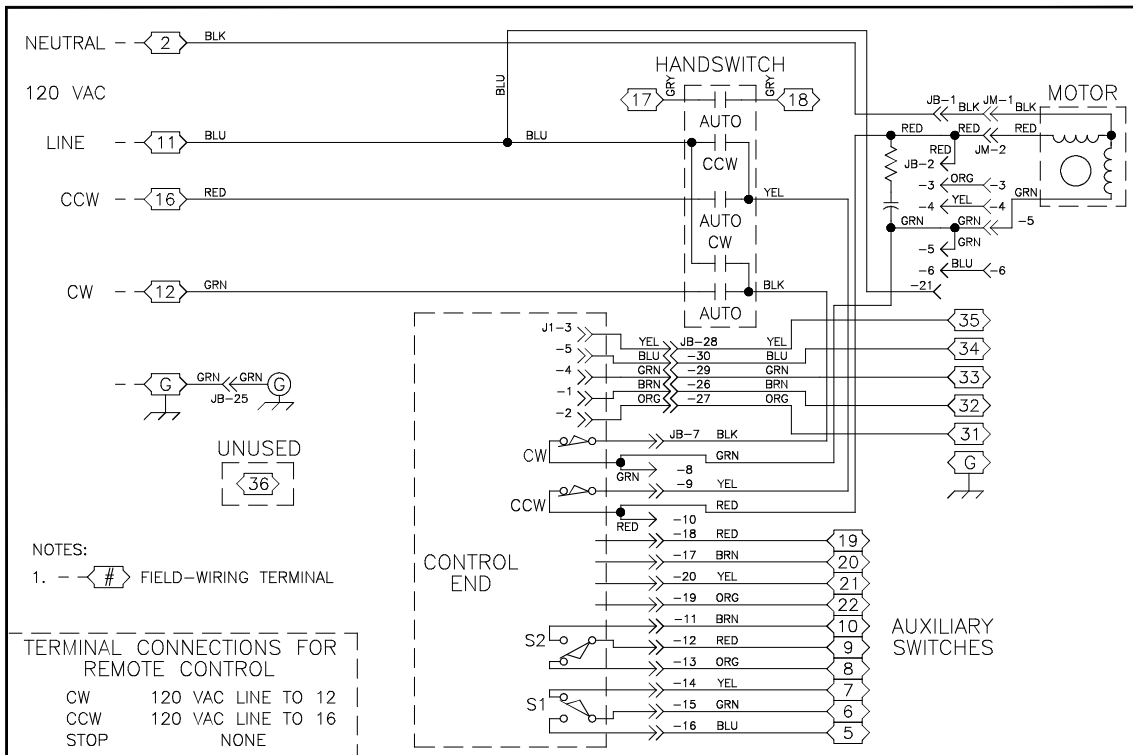

OPERATION

HOUSING

Beck actuators have individual cast aluminum compartments for each of the main components: The control motor, wiring terminal block, and control end. Gasketed covers and sealed shafts make the actuators ideally suited to outdoor and high humidity environments.

Mechanical stops built into the housing allow for 108° of rotation and are designed to prevent accidental over-travel damage during manual cycling.

CONTROL MOTOR

The Beck control motor is a synchronous inductor motor which operates at a constant speed of 72 RPM or 120 RPM in synchronism with the line frequency.

Motors are able to reach full speed within 25 milliseconds and stop within 20 milliseconds; actual starting and stopping times will vary with load.

Beck motors have double grease-sealed bearings and require no maintenance for the life of the motor.

GEARING

The spur gear set is constructed with only heat-treated alloy steel and ductile iron for durability and long life.

The gearing consists of the control motor and Handwheel, reduction gears, main gear and output shaft.

SELF-LOCKING MECHANISM (SLM)

An integral part of every control motor is the self-locking mechanism. This mechanical device couples the motor to the gear train and transmits full motor torque when rotated in either direction. When the motor is de-energized, the SLM instantaneously locks and holds the output shaft in position.

HANDWHEEL

Every Beck actuator is furnished with a Handwheel to permit manual operation of the driven element without electrical power. Its solid construction design includes no spokes or projections, and turns at a safe, slow speed. The Handwheel is located at the rear of the control motor housing. The Handwheel is coupled directly to the motor shaft and rotates when the motor runs. Manual operation of the Handwheel (with electric Handswitch in "STOP" position) turns the motor and the rest of the drive train without incorporating a clutch.

HANDSWITCH

A local electric Handswitch is provided on Beck actuators to permit operation at the valve or damper, independent of the controller. As a safety feature, the Handswitch is designed so that the controller can operate the actuator only when it is in the "AUTO" position. The sequence of the Handswitch is: "AUTO", "STOP", "CW", "STOP", "CCW".

In the "AUTO" position, two contacts are closed and an external controller contact completes the control circuit.

In the "CW" or "CCW" positions, contacts are closed to operate the actuator independently of the controller.

In the "STOP" position, all contacts remain open.

LIMIT SWITCHES

Two over-travel limit switches (control options 5 and 6) or two end-of-travel limit switches (control option 3) and up to four optional auxiliary switches are provided. Switch cams are clamped onto the control shaft which rotates in relation to the output shaft. Cam position is field-adjustable. Switches are rated 3 A, 120 V ac. All auxiliary switch connections are made on the terminal block.

CONTROL OPTIONS

Actuators described in this manual are controlled by 120 V ac contact closure. Each option is described below.

Open / close option 3: For simple 2-position control using manual push-buttons or an automatic controller. Preset end-of-travel limit switches provide open / close operation upon closure of an automatic controller or manually operated switch. Travel limits are adjustable over the full range of travel and provide precise positioning repeatability.

Direct AC control option 5: Provides continuous positioning capability over the full range of actuator travel by direct AC control from either an automatic controller or manually operated switches. Includes a 1,000 ohm film potentiometer for remote feedback.

Direct AC control option 6: Provides continuous positioning capability over the full range of actuator travel by direct AC control from either an automatic controller or manually operated switches. Includes a 2-wire Contactless Position Sensor (CPS-4) for feedback and position indication.

START-UP

POSITION FEEDBACK: CONTACTLESS POSITION SENSOR (CPS-4)

The 2-wire CPS-4 provides a continuous feedback signal proportional to the position of the actuator's output shaft. The position sensing function of the CPS-4 is provided by a ferrite magnetic sensing element. An electronic circuit translates the signal from the ferrite magnetic sensor into an analog position feedback signal designed to interface with electronic control systems and indicating instruments.

POSITION FEEDBACK: FILM POTENTIOMETER

The film potentiometer produces a voltage that is a fraction of the voltage applied across its resistive element. That voltage fraction is determined by the position of the wiper on the resistive element.

START-UP

NOTE: All Beck actuators are shipped from the factory ready for installation. Each actuator is set-up and calibrated to the customer's specifications that were written into the equipment order. Electrical adjustments are generally not required before placing the actuator in operation.

START-UP CHECKLIST

The following list provides some basic checks that should be performed before placing your actuator into operation.

- Inspect the location and the mounting bolts. Be sure the actuator is securely fastened to its mounting base.
- On the first start-up, place the Handswitch in a STOP position to ensure that the output shaft will not move and possibly cause personal injury.
- Confirm the actuator is receiving the appropriate operating voltage as shown on the nameplate.
- Confirm the actuator moves fully to both the CW and CCW ends of travel.

CONFIGURATION/CALIBRATION

NOTE: Your Beck actuator was shipped from the factory ready for installation; no electrical adjustments are required before placing it in operation. Each actuator is set up and calibrated to the specifications that were written into the equipment order.

Under normal operating conditions there is no need to recalibrate the actuator. However, if the application requirements change—or are different than specified on the equipment order—the actuator should be recalibrated according to the following procedures.

LIMIT SWITCHES

Over-travel limit switches (options 5 & 6) are factory set $1/2^\circ$ outside each end of travel unless otherwise specified at the time of order. End-of-travel limit switches (options 3) are factory set at each end of travel unless otherwise specified at the time of order. Limit switches must be set inside the range of the built-in, non-adjustable mechanical stops to prevent the possibility of stalling when operating the actuator with the Handswitch. Limit switches can be reset to limit over-travel of the output shaft when travel of the output shaft has been reduced (60° minimum).

NOTE: The limit switches are the switches closest to the actuator body. To adjust the limit switches, it is necessary to remove the control end cover.

Switches are operated by cams which are clamped onto the control shaft. In the following procedure, the use of a continuity meter is recommended to determine when the switch opens or closes. If such a meter is not available, it is possible to hear the switch click as the contacts open and close.



CAUTION

Do not attach the meter or attempt to adjust the switch cams until the actuator is disconnected from the line voltage and auxiliary switches are disconnected from external power sources.

SETTING LIMIT SWITCHES CW AND CCW

This procedure should be used if the factory limit switch settings must be changed in the field. It is advisable to operate the actuator fully in each direction using the electric Handswitch to check switch settings before attempting to change them. Follow these instructions if they require adjustment:

1. Remove the control end (position sensing device) cover and terminal block cover ($3/16$ " hex wrench).
2. Move the output shaft to the desired CW limit.
3. Turn the Handswitch to the "STOP" position.
4. **Disconnect power from the actuator.**
5. Connect a continuity meter across terminals 2 and 3.
6. Insert a small screwdriver into one of the slots on the CW cam. Carefully rotate the cam until the meter shows no continuity (switch contacts open, switch clicks).
7. Disconnect meter and ensure the Handswitch is in the "STOP" position.
8. Reconnect actuator power.
9. Rotate the actuator's output shaft in the CCW direction away from the CW travel limit. Note the direction of rotation on the lobe of the cam. The correct cam lobe motion is away from the switch lever with the switch lever on the lower part of the cam. If not correct, return to step 2 and adjust the cam position such that the opposite end of the lobe presses against the switch lever at the desired "trigger" position of the output shaft.
10. Rotate the output shaft again to the desired CW travel limit. If the stopping point is reached, the switch is properly set.
11. Repeat steps 2–10 for setting the CCW travel limit switch (noting that referenced directions of rotation should be opposite of those used for the CW switch setting). Connect continuity meter across terminals 2 and 4.
12. Replace covers and tighten cover screws to 6 lb-ft (8 N•m) torque.
13. If applicable, rotate the index pointer on the output shaft to correspond with the new output shaft position range.

CALIBRATION *Direction Change*

DIRECTION OF OUTPUT SHAFT ROTATION

The direction of output shaft rotation is determined by observing the end of the actuator output shaft. The rotation direction desired from an increasing signal—clockwise or counterclockwise—should be specified at the time of order. If not specified, the output shaft is factory-set to rotate clockwise in response to an increasing signal.

NOTE: Changing direction of rotation does not change the setting of the auxiliary switches.

CHANGING DIRECTION OF OUTPUT SHAFT ROTATION

Procedures vary depending upon the actuator model number. The number is listed on the actuator nameplate. Determine the model number and refer to one of the following procedures.

Model 75-103

No changes are necessary, other than resetting the travel index (if applicable).



CAUTION

Be sure the actuator is disconnected from the line voltage and that all auxiliary switches are disconnected from external power sources before beginning the direction change procedure for model 75-105.

Model 75-105

1. Remove the control end cover (3/16" hex wrench).
2. Interchange the wires connected to terminals 31 and 35 on the terminal board (i.e., the wire to terminal 31 should be moved to terminal 35 and vice versa). The wire to terminal 33 should not be moved.
3. Reset the travel index (if applicable).
4. Reset the potentiometer wiper according to the film potentiometer calibration instructions on the following page.



CAUTION

While performing the procedure below for model 75-106, be careful to avoid the power terminals.

Model 75-106

1. Remove the terminal compartment cover and control end cover (3/16" hex wrench).
2. In the terminal compartment, connect a mA meter to the Feedback terminals (35(+) & 33 (-)).
3. Position the actuator to its 0% position and place the Handswitch in "STOP". Ensure the Position feedback signal reads 4 mA.
4. Change the CPS-4 rotation setting to match the desired actuator travel direction. For example, to change from CW to CCW, turn the rotation switch (see image below) fully CCW to the switch's hard stop (turn fully CW to switch from CCW to CW).
5. Following the example above, the Position feedback signal from the CPS-4 should now have shifted from 4 mA to approximately 20 mA. Adjust the Zero Pot. on the CPS-4 (see image below) until the Position feedback signal is exactly 20 mA.
6. Run the actuator to the 0% and 100% travel positions and verify that the Position feedback signal is correct.
7. Remove the mA meter.
8. Replace the covers and tighten cover screws to 6 lb-ft (8 N•m) torque.

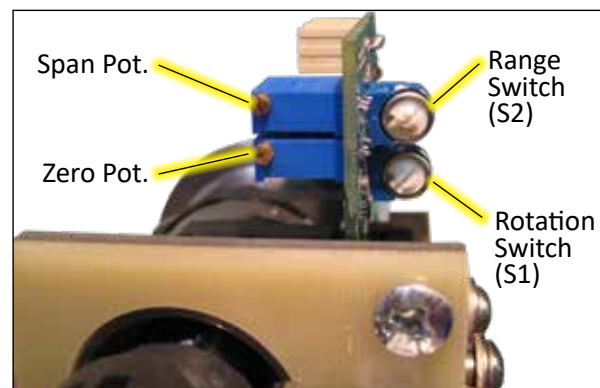

CPS-4 SWITCHES & POTS.

NOTE: The Range Switch (S2) is factory set to fully CW and should remain in that position.

CALIBRATION Feedback Signal

FEEDBACK SIGNAL CALIBRATION

All actuators are shipped with the feedback calibrated for full 100° travel of the output shaft unless otherwise specified at the time of order. If changes have been made to your actuator, feedback signal calibration may be necessary to ensure that the signal correctly corresponds to the actuator's output shaft position. Minimum shaft travel available on Group 75 actuators is 60°.

The procedure to check and set feedback calibration varies by model number. The model number is listed on the actuator nameplate. Determine the model number and refer to the applicable procedure that follows.

NOTE: The travel limit switches should be properly adjusted before the feedback signal is calibrated.

Film Potentiometer Calibration Model 75-105

When properly adjusted (unless travel direction and feedback has been reversed), the potentiometer feedback signal should be maximum (20 mA) with the actuator output shaft at the 100% (maximum input signal) position. At 50% of travel the signal should be mid-span. At the 0% position, the signal should be minimum (4 mA). If the potentiometer is out of calibration, follow the steps below (refer to the image on page 24 for component identification):



CAUTION

To prevent damage to the potentiometer:

- do not allow the washers to touch the wire contact surfaces.
- do not touch the wipers on the back of the insulator/wiper assembly.

1. Apply power to the actuator. Do not touch the power terminals or any switches.
2. Remove the control end cover (3/16" hex wrench).
3. Connect a multimeter between terminals 33 & 35 on the terminal board.
4. Move the actuator to the 0% travel position. Note the resistance value.
5. Move the actuator to the 100% travel position. Note the resistance value.
6. Calculate the resistance between the values noted in Steps 4 & 5.
7. Move the actuator to the approximate midpoint of travel between the hard (mechanical) stops. The flat of the control shaft should be level with the top of the actuator.
8. Loosen the (4) potentiometer retaining screws (4-40 x .750 socket head) and rotate the silver, rectangular washers so that they are no longer holding the potentiometer in place.
9. Gently rotate the potentiometer until the meter shows the total of half of the resistance value calculated in Step 6 *plus* the minimum resistance value noted in Step 4.
10. Rotate the (4) silver, rectangular washers so that they are once again holding the potentiometer in place. Tighten the (4) potentiometer retaining screws to 5 lb-in (0.6 N•m).
11. Ensure proper operation.
12. Disconnect multimeter.
13. Replace the cover and tighten cover screws to 6 lb-ft (8 N•m) torque.

CALIBRATION Feedback Signal

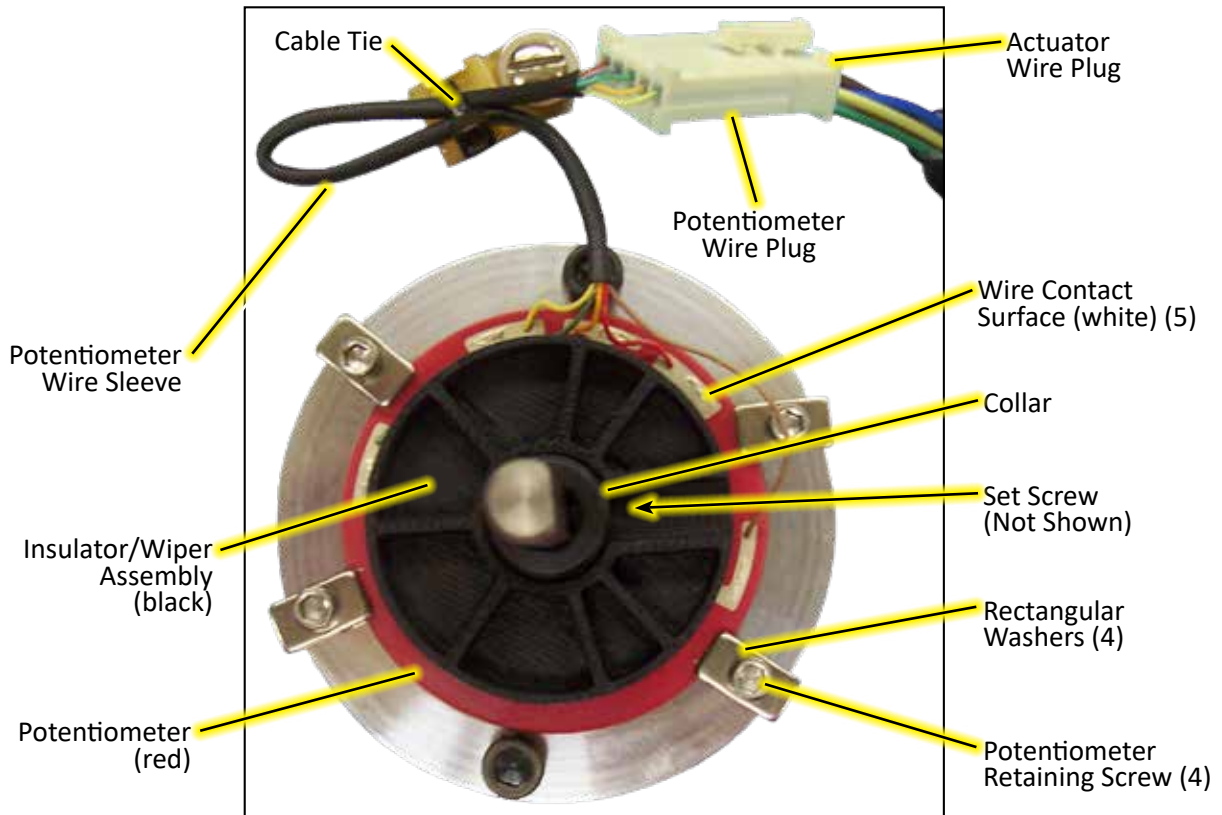
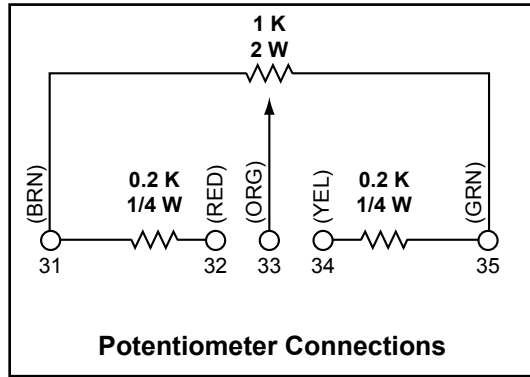

FILM POTENTIOMETER COMPONENTS

CPS-4 Calibration Model 75-106

CPS-4 units are designed to provide position feedback without contacting or wiping surfaces. The CPS-4 provides infinite resolution by incorporating a ferrite rotor on the control shaft and a ferrite stator mounted on the position sensing circuit board. To adjust the feedback signal, first adjust the span, then change the position of the rotor on the control shaft to adjust the zero.

Checking Feedback Signal Calibration



CAUTION

While performing the procedure below, be careful to avoid the power terminals.

The following procedure should be followed to check CPS-4 calibration:

1. Put electric Handswitch in "STOP" position.
2. Remove the terminal cover and the control end cover (3/16" hex wrench).
3. In the terminal compartment, connect a mA meter to the feedback terminals (35(+)) & 33(-)).
4. Drive the output shaft through its full range and check the feedback signal. When properly adjusted, the feedback signal should be maximum with the actuator's output shaft at the 100% (maximum input signal) position. At 50% travel the signal should be mid-span. At 0%, the signal should be minimum. If not correct, use the Calibration Procedure below.

NOTE: Tolerance on factory calibration is $\pm 0.5\%$ of span.

Calibration Procedure



CAUTION

While performing the procedure below, be careful to avoid the power terminals.

Adjustment of the CPS-4 is necessary if the signal range requires an increase or decrease in value relative to the actuator's output shaft rotation. Calibrate by turning the span potentiometer CW to increase the gain of the CPS-4. This has the effect of increasing the

output at the high end and lowering the output at the low end equally.

Refer to the image on page 22 for CPS-4 component identification.



CAUTION

Do not adjust the zero potentiometer to shift the span.

To adjust the span, turn the span potentiometer on the CPS-4 circuit board. The span potentiometer adjusts the CPS-4 so that an actuator output shaft rotation from 60° to 100° produces the specified output signal range.

1. Put electric Handswitch in "STOP" position.
2. Remove the terminal cover and the control end cover (3/16" hex wrench).
3. In the terminal compartment, connect a mA meter to the feedback terminals (35(+)) & 33(-)).
4. Move the actuator to the 0% and 100% positions and record the CPS-4 output at these positions.
5. Subtract the outputs recorded at the two positions and compare with the desired output signal span (e.g., 16 mA for a 4–20 mA signal range). The difference between the measured span and the desired span is the span error.
6. With the actuator at the 100% position, turn the span potentiometer to adjust the CPS-4 feedback signal by 1/2 of the span error calculated in step 5. Turning the span potentiometer CW increases the span equally at both ends. Turning the span potentiometer CCW decreases the span equally at both ends.
7. Run the actuator to the 0% and 100% positions and check the feedback signal for desired span. If not correct, repeat the procedure from step 4.
8. Remove the meter.
9. Replace covers and tighten cover screws to 6 lb-ft (8 N•m) torque.

MAINTENANCE

MOTOR ASSEMBLY

The control motor is not field-repairable. **Do not disassemble the motor.** Disassembly of the motor will result in a loss of torque that can only be restored by returning the motor to the factory for re-magnetizing.

Motor assembly replacement instructions follow:



WARNING

Disconnect power before proceeding.

Before removing the motor assembly, block the crank arm (if applicable) to prevent the crank arm and gear train from moving when the motor is removed.

REMOVE THE MOTOR ASSEMBLY:

Disconnect power from the actuator.

Loosen the four captive, socket head cap screws (3/16" hex wrench) holding the motor to the actuator body.

Gently pull the motor straight back from the actuator until it is free from the wire connector.

Inspect the motor enclosure gasket for damage and replace, if necessary (see page 35).

INSTALL THE NEW MOTOR ASSEMBLY:

Align the screws on the new motor assembly with the screw holes on the actuator. This will also align the wire plug on the new motor assembly with the connector on the actuator.

Tighten the screws to 6 lb-ft (8 N•m).

Captive Motor Screws
(4 places)

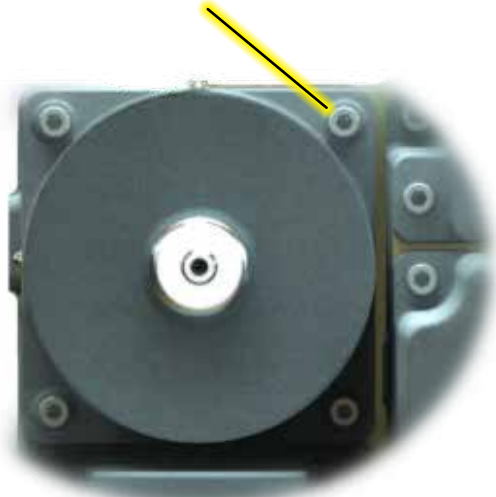

MOTOR ASSEMBLY

LUBRICATION

Periodic lubrication is not required on Beck actuators.

MOTOR CAPACITOR AND RESISTOR ASSEMBLY

There is no recommended replacement interval for the capacitor and resistor assembly, but they are recommended spare parts. It may be advisable to replace the assembly as a preventative maintenance measure when motors are replaced on older actuators.



WARNING

Electrical shock hazard. Disconnect power before proceeding.

The part numbers and values for each assembly are shown in the "Motors, Resistors & Capacitors" table on page 36. The assembly is located beneath the Handswitch and terminal enclosure.

To replace the capacitor and resistor assembly:

Disconnect power from the actuator.

Loosen the four (three, if an electronic enclosure) captive, socket head cap screws (3/16" hex wrench) holding the enclosure to the actuator body (see image at the top of page 27).

Gently pull the enclosure straight back from the actuator until it is free from the wire connector—this will expose the capacitor and resistor compartment (beneath the connector, see image at the bottom of page 27).

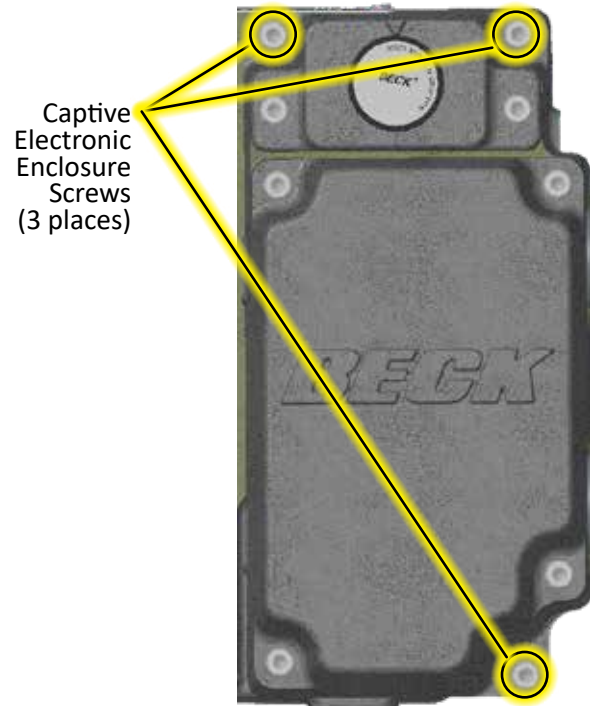
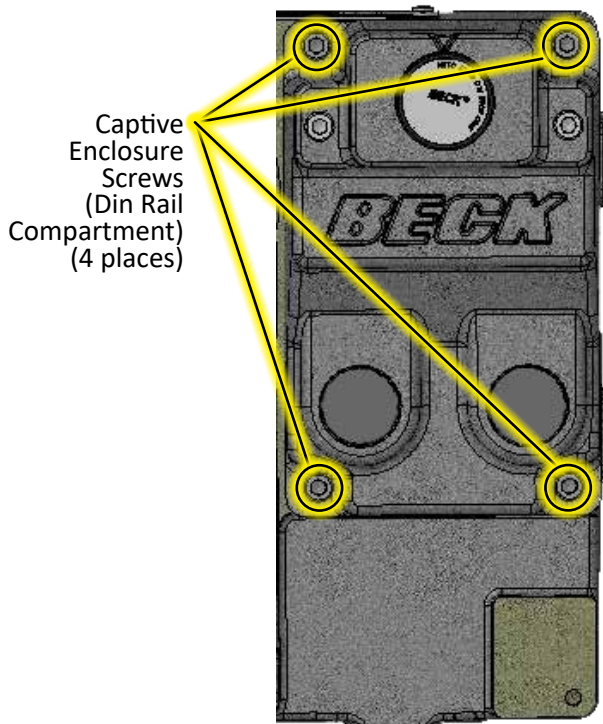

REMOVE THE ASSEMBLY:

Cut the capacitor wire and the green connector wire at the wire joint terminal.

Cut the red resistor wire and the red connector wire at the wire joint terminal.

Cut the capacitor cable ties.

Remove the resistor retaining screws and discard the removed capacitor and resistor assembly.

INSTALL THE NEW ASSEMBLY:

Attach the new resistor using the replacement screws provided (be careful not to pinch any wires).

Attach the capacitor to the brackets (not shown) on the actuator using the two cable ties provided (be careful not to pinch any wires).

Insert the green connector wire and the capacitor wire into a wire joint terminal (provided) and crimp using a crimping tool or pliers.

Insert the red connector wire and the resistor wire into a wire joint terminal (provided) and crimp using a crimping tool or pliers.

Inspect the enclosure gasket for damage and replace, if necessary (see page 35).

Replace the enclosure. Torque the screws to 6 lb-ft (8 N•m).

ENCLOSURE REMOVED TO REVEAL CAPACITOR & RESISTOR COMPARTMENT

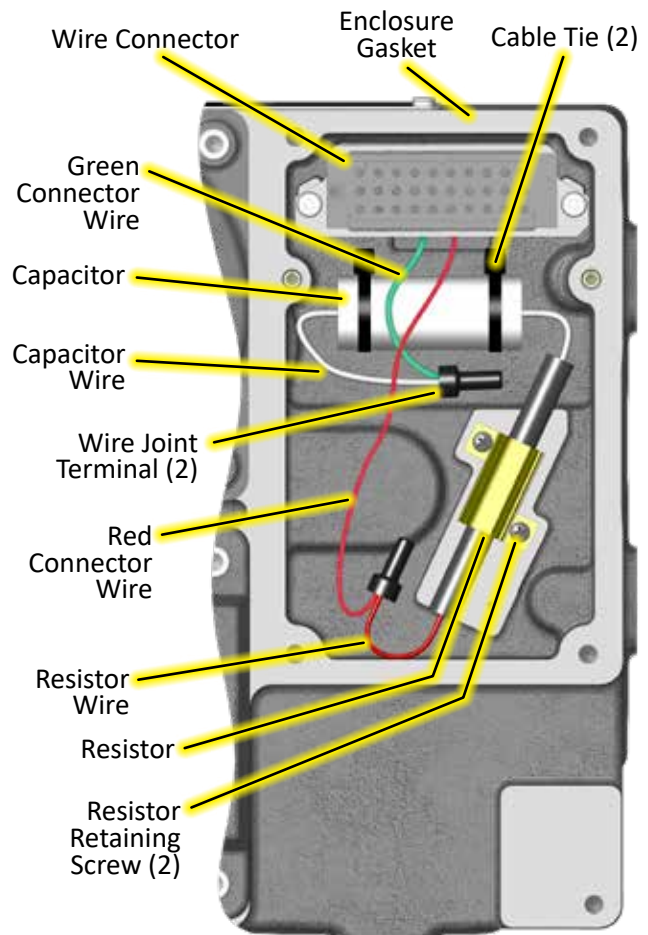

MAINTENANCE

SELF LOCKING MECHANISM (SLM)

The Self Locking Mechanism (SLM) is assembled to the front of the motor and couples the motor to the gear train. The primary function of the SLM is to lock the gear train in place when the motor is de-energized. When the motor is energized, the SLM releases and allows the motor to drive the gearing.

There is no recommended maintenance interval for the SLM. The SLM can last for many years in normal service. SLM wear is a function of loading and the number of starts/stops the motor experiences over time. Overloading or stalling the motor will accelerate SLM wear.

Signs of wear include the inability of the actuator to hold position when the motor is de-energized. This could result in constant on-off oscillation. Severe SLM wear or damage may result in a loss of torque at the output shaft.

It is often possible to confirm SLM wear or damage by checking motor operation with the Handwheel. Place the Handswitch in the STOP position, and rotate the motor Handwheel back and forth. There should be free play before the motor pinion/gearing turns (up to one tenth of a full Handwheel rotation). Lack of free play or rough motor movement may indicate the need for SLM reconditioning.

Disassembly and close inspection of the SLM components is required to evaluate its condition.

SLM REPLACEMENT KIT (P/N 12-8064-23)

Description	Part Number
Gasket, Motor	20-0661-56
Friction Material	13-0080-06
Steel Ball	14-9420-06
Locking Disc	14-9330-40
Spring	14-9980-10
Pinion	14-9940-70
Thrust Washer	14-9400-16
Stop Collar	14-9380-04
Spring Pin	10-7111-06



WARNING

Electrical shock hazard. Disconnect power before proceeding.



WARNING

Support the load before removing the motor/SLM from the actuator.

DISASSEMBLY AND CLEANING

When wear or damage is suspected, disassembly and cleaning may be required to determine the extent of needed repairs. Individual parts may be replaced, with the exception of the drive collar, which is not field replaceable. Refer to the illustration at right.

For SLM disassembly and inspection:

1. Disconnect power from the actuator.
2. Secure the actuator load, and remove the motor assembly (see page 26). Handle the motor with care so as not to damage the rotor shaft.
3. Pushing down firmly on the pinion, measure the gap between the stop collar and the thrust washer. This distance should measure $0.015'' \pm 0.005''$. A larger gap indicates worn SLM components.
4. Use a felt tip pen to mark the location of the stop collar on the shaft. Support the end of the rotor shaft to prevent it from bending, and drive the 1/8" spring pin out.
5. Carefully (the assembly is spring loaded), remove the stop collar, thrust washer, pinion, spring, and steel balls (4).
6. Remove the locking disc and (4) steel balls from the drive collar.



CAUTION

Do not disassemble the motor any further, as it has no other user serviceable parts. Further disassembly will result in demagnetization of the motor and loss of the required torque.

7. Clean grease from the pinion and locking disc for inspection. A small amount of dust residue from the friction material is normal. Clean the drive collar detents with a rag and inspect for wear. Inspect the friction material for excessive wear or damage. If the friction material does not appear to be damaged, clean with alcohol to remove any contaminants.
8. Identify worn parts and replace as needed. Note that deformation of the conical detent sockets is cause for replacement of the pinion and locking disc.

REPLACEMENT AND REBUILD INSTRUCTIONS

1. If the friction material requires replacement, scrape off the old friction material and clean the bonding surface to ensure flatness for the new friction material. Glue the new friction material in place with Momentive 159 silicone RTV or equivalent, taking care to keep the material flat and clean. Allow 24 hours for the RTV to cure.
2. With the motor shaft pointed up, place a steel ball into each of the drive collar detents. Install the locking disc and place a steel ball into each of the detents on the top of the locking disc.
3. Install the pinion, thrust washer (the white side of the thrust washer should face the pinion) and stop collar. Make sure all steel balls are properly seated in the detents of the drive collar,
- locking disc, and pinion. Align the stop collar and shaft marks made during disassembly and insert a 1/8" pilot punch through the stop collar hole and into the motor shaft to hold it in place.
4. Pushing down firmly on the pinion, measure the gap between the stop collar and the thrust washer. This distance should measure $0.015" \pm .005"$. This space is necessary to ensure proper operation. Add shims as necessary. Install the new 1/8" spring pin while supporting the outboard end of the shaft.
5. Install the spring by slipping it over the pinion flange and twisting it into place.
6. Inspect the motor gasket for damage and replace, if necessary (see page 35).

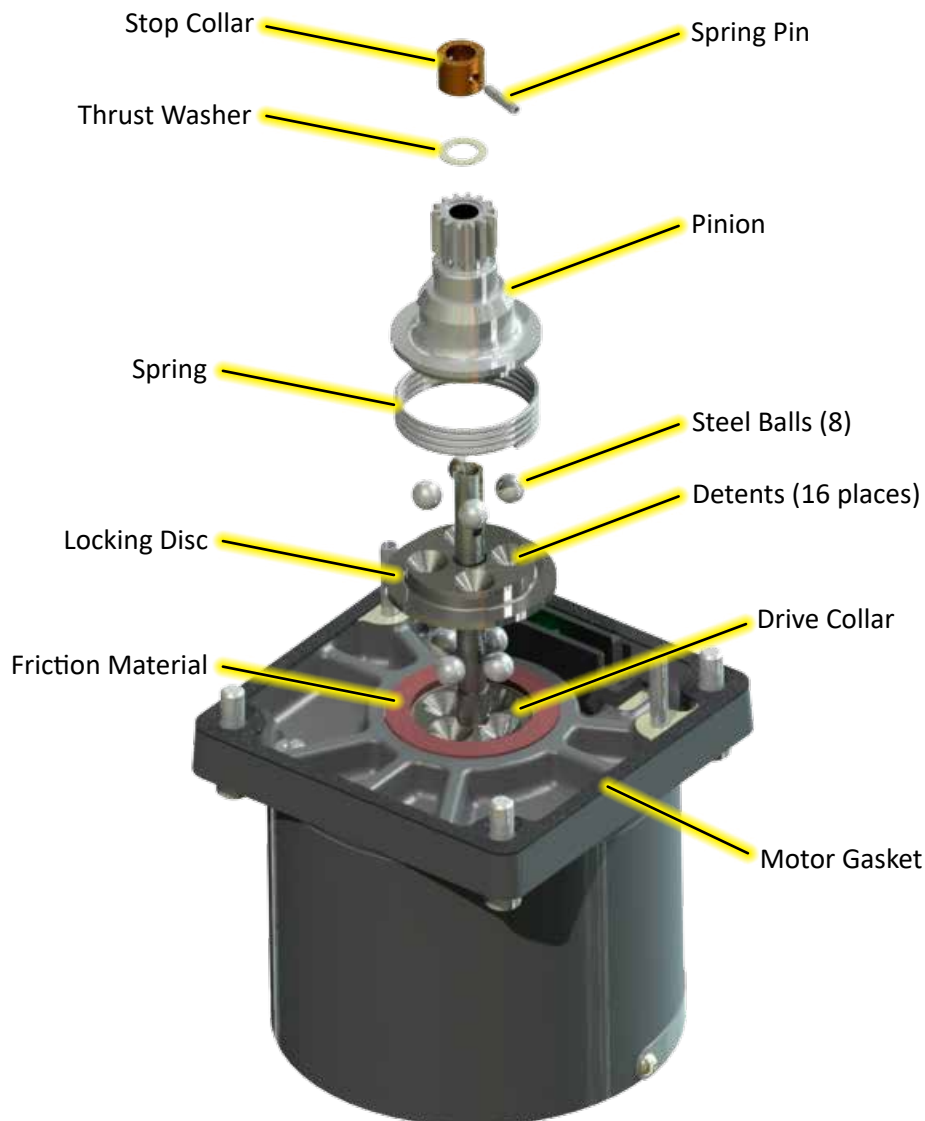

SLM COMPONENTS

MAINTENANCE

TERMINAL BOARD REPLACEMENT (ELECTRONIC ENCLOSURE)

Field repair of the terminal board is not recommended.



WARNING
Electrical shock hazard. Disconnect power before proceeding.

Refer to the illustration below and on the opposite page for component identification.

Remove the Terminal Block compartment cover (four captive, socket head cap screws (3/16" hex wrench)).

The terminal board is attached to an "L" bracket which is mounted to the actuator inside the DCM/Terminal Block compartment. The "L" bracket must be detached from the actuator to allow access to the terminal board mounting screws.

Remove the "L" Bracket

Remove the plugs attached to the 5 connectors on the terminal board (two connectors each on the top & bottom of the board and one connector on the logo side of the board) and note which plug attaches to which connector. Also note the location of any wires attached to the terminals of the terminal board and remove. Remove any wire(s) attached to the grounding screws (green screws) on the terminal board.

Find the location of the three countersunk socket head cap screws attaching the "L" bracket to the actuator. While supporting the bracket, remove the cap screws and set aside.

Remove the Terminal Board

Place the "L" bracket on a flat surface with the terminal board side facing up. Remove the four cross recessed screws attaching the terminal board to the bracket. Note the position of the paper shock shield & the paper label with printed terminal numbers. Set aside the paper shield and label for later use.

Install the new Terminal Board

Align the new terminal board with the appropriate mounting holes on the "L" bracket (as depicted on page 31). Attach the terminal board to the bracket using the four cross recessed screws—ensure that the paper shield and label are positioned properly. Torque the screws to 10 lb-in (1.1 N•m).

Reattach the "L" Bracket to the Actuator

Align the countersunk screw holes (3) to the mounting holes on the actuator. Tighten the socket head cap screws (removed earlier) to 19 lb-in (2.1 N•m).

Reattach the Wiring to the Terminal Board

Attach the plugs to the appropriate connectors (as noted earlier) on the new terminal board. Attach wires (noted earlier) to their proper terminals. Reattach any wire(s) to the grounding screws.

Replace the Terminal Block Compartment Cover

Reattach the cover to the actuator by tightening the four captive, socket head cap screws to 6 lb-ft (8 N•m).

Terminal Block
Compartment Cover
Screws
(4 places)

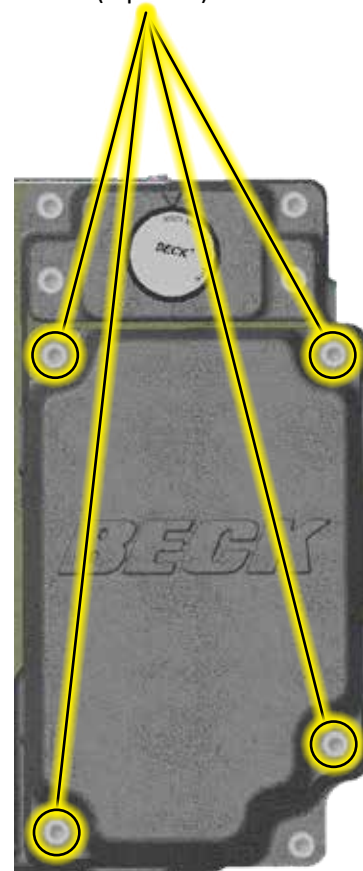

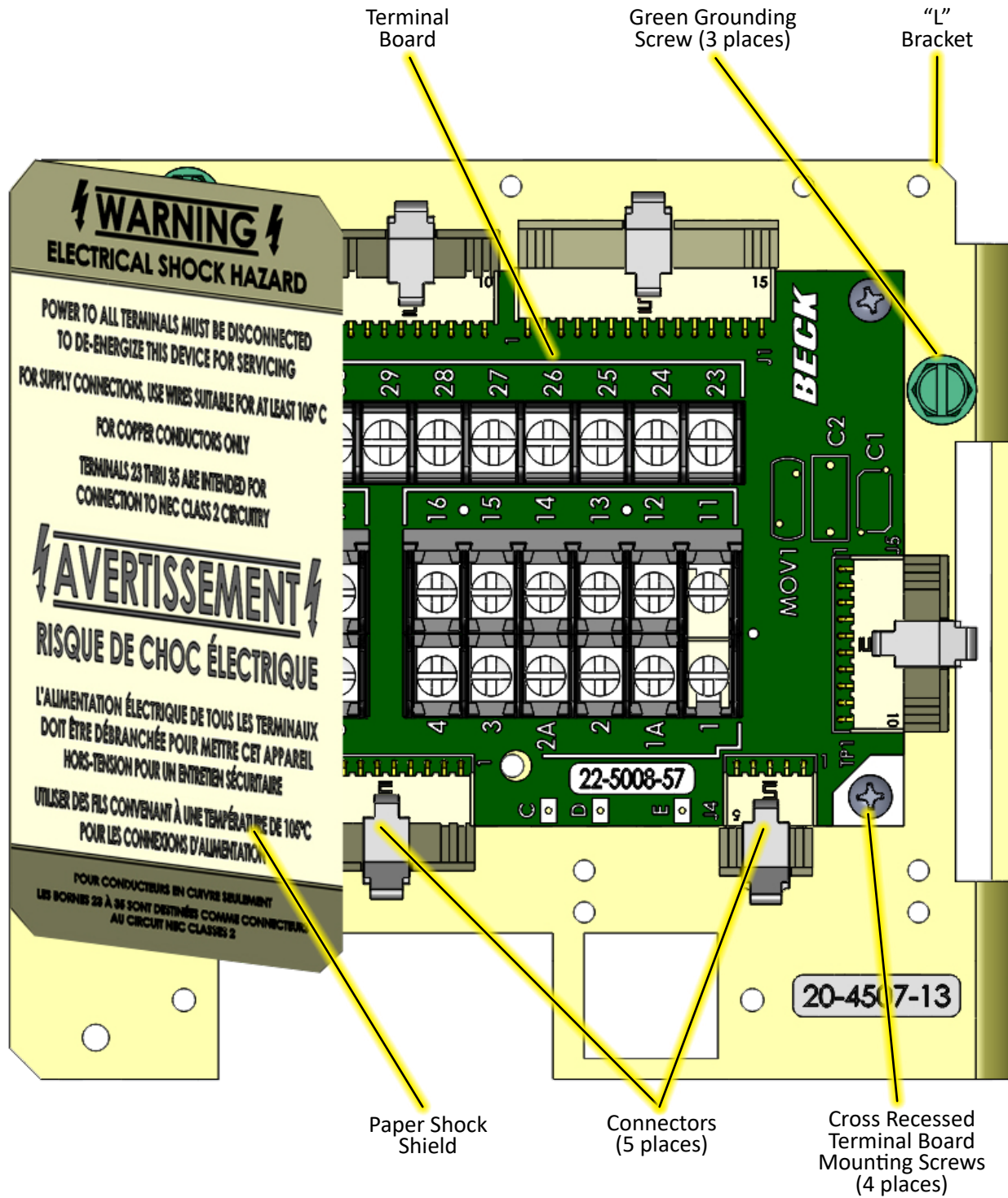

TERMINAL BOARD AND "L" BRACKET

MAINTENANCE

LIMIT AND AUXILIARY SWITCHES

Complete switch assemblies may be replaced. It is not possible to replace individual switches. To replace switch assemblies, follow the instructions below.



WARNING

Electrical shock hazard. Disconnect power before proceeding.

Remove the control end cover by loosening the four captive, socket head cap screws (3/16" hex wrench). Remove the screws holding the switch assembly to the switch plate and slide it out to the side.

Transfer the wires to the terminals of the replacement assembly, ensuring the correct wire is transferred to the correct replacement assembly terminal (wires have push-on lugs). Install the replacement assembly and note that it rotates around one screw to permit an adjustment of the cam-to-switch lever spacing and switch operating point. To set the switch, place a .030" (.75 mm) shim between the cam and switch lever (see photo to right). The switch lever should be on the low or minimum radius portion of the cam when setting the switches. Position the switch assembly so that the switch is just actuated. **DO NOT** overstress the switch lever. Tighten both screws to 10 lb-in (1.13 N•m) torque (using the rectangular washer to cover the gap in the mounting plate) and remove the shim. When properly adjusted, the switch's cam actuated lever will remain in contact with the cam throughout the actuator travel.

ADDING AUXILIARY SWITCHES

If the actuator has two auxiliary switches, or no auxiliary switches, it is possible to add auxiliary switches in the field. Auxiliary switches are available as an assembly consisting of 2 or 4 switches. A Group 75 actuator may have up to four total auxiliary switches.

Remove the control end cover by loosening the four captive, socket head cap screws (3/16" hex wrench). Attach the new switch assembly to the mounting plate (see illustration at the top of this page) using the screws provided -- ensuring that the levers are oriented in the same direction as the limit switches. Adjust according to the preceding instructions.

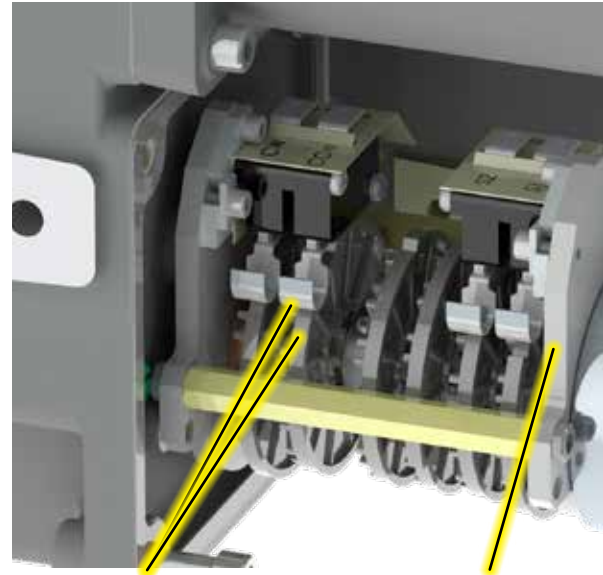

.030" (.75 mm) shim should be inserted between all levers and cams when setting switches.

Mounting Plate

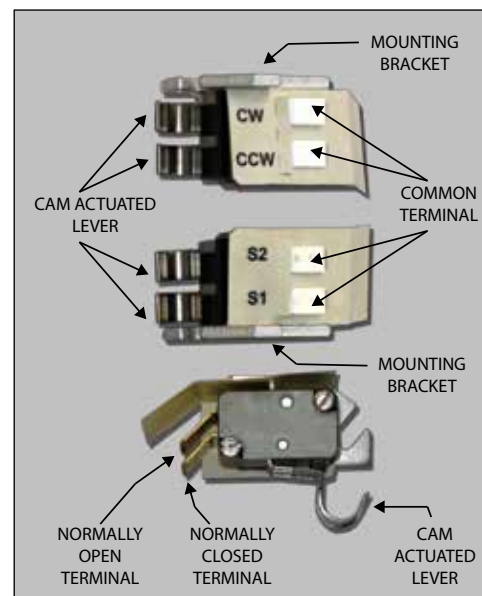

FILM POTENTIOMETER

Field repair of the Film Potentiometer assembly is not recommended. The factory maintains a stock of replacement assemblies for immediate shipment. Follow the instructions below. Refer to the image on page 24 for component identification.



WARNING

Electrical shock hazard. Operating voltage is supplied across CW and CCW limit switches. Disconnect power before replacing the potentiometer.

REMOVE THE EXISTING POTENTIOMETER:

1. Remove power from the actuator.
2. Remove the control end cover by loosening the four captive, socket head cap screws (3/16" hex wrench).
3. Carefully cut the cable tie securing the potentiometer wire sleeve (note location of tie).
4. Detach the potentiometer wire plug from the actuator wire plug.
5. Loosen the set screw holding the insulator/wiper assembly to the flat of the control shaft.
6. Pull the insulator/wiper assembly off of the control shaft.
7. Loosen the (4) potentiometer retaining screws (4-40 x .750 socket head) and rotate the silver, rectangular washers so that they are no longer holding the potentiometer in place.
8. Pull the potentiometer off of the control shaft.

INSTALL THE NEW POTENTIOMETER:

9. Slide the new potentiometer onto the control shaft, ensuring it is flat against the mounting plate with the wire side facing away from the actuator. Orient the potentiometer so that the wire sleeve is at the top of the mounting plate.
10. Rotate the (4) silver, rectangular washers so that they are holding the potentiometer in place. Tighten the (4) potentiometer retaining screws (4-40 x .750 socket head) to 5 lb-in (.56 N•m).



CAUTION

To prevent damage to the potentiometer, do not allow the washers to touch the wire contact surfaces.

11. Carefully slide the insulator/wiper assembly onto the control shaft, ensuring that the wipers face the potentiometer and that the set screw on the collar is on the flat of the control shaft. Gently push the insulator/wiper assembly until it is flat against the potentiometer—being careful not to pinch any wires.



CAUTION

To avoid damage, do not touch the wipers on the back of the insulator/wiper assembly.

12. Tighten the set screw to 2 lb-in (.23 N•m).
13. Connect the potentiometer wire plug to the actuator wire plug.
14. Using a cable tie, secure the potentiometer wire sleeve in the same location as noted in Step 3.
15. Follow the procedure on page 23 to calibrate the potentiometer.

MAINTENANCE

CPS-4 (2-WIRE)

Field repair of the CPS-4 is not recommended. The factory maintains a stock of replacement assemblies for immediate shipment. Refer to the image below for reference.

REMOVE THE EXISTING CPS-4:

1. Remove the control end cover by loosening the four captive, socket head cap screws (3/16" hex wrench).
2. Disconnect the actuator wire plug from the CPS-4 board.
3. Use a fine-point marker to mark the position of the CPS-4 relative to the mounting plate. Mark the plate immediately adjacent to the top of the cutout in the CPS-4.
3. Loosen the four screws (4-40 x 3/8" socket head) and clamps that hold the CPS-4 to the mounting plate. Rotate the clamps so that they are no longer holding the CPS-4 in place.
4. Loosen the outermost setscrew (at the end of the control shaft). Do not loosen the inner setscrew.
5. Gently pull the CPS-4 assembly off of the control shaft.

INSTALL THE NEW CPS-4:

6. Gently slide the new CPS-4 assembly onto the control shaft. Ensure that the top of the notch in the CPS-4 is aligned with the mark from Step 3.
7. Adjust the 4 clamps to hold the CPS-4 in place and tighten the clamp screws to 5 lb-in (.56 N•m).
8. Ensure that the outermost setscrew is aligned with the flat of the control shaft and tighten to 15 lb-in (1.7 N•m). Do not tighten the inner setscrew.
9. Connect the actuator plug to the plug receptacle on the CPS-4 board.
10. Test the actuator for proper operation.
11. If the actuator responds as expected, reinstall the control end compartment cover. First, however, check the gasket for damage and replace, if necessary (see page 35). Tighten screws to 6 lb-ft (8 N•m).
12. If the CPS-4 is not performing as expected, refer to the calibration instructions on page 25.

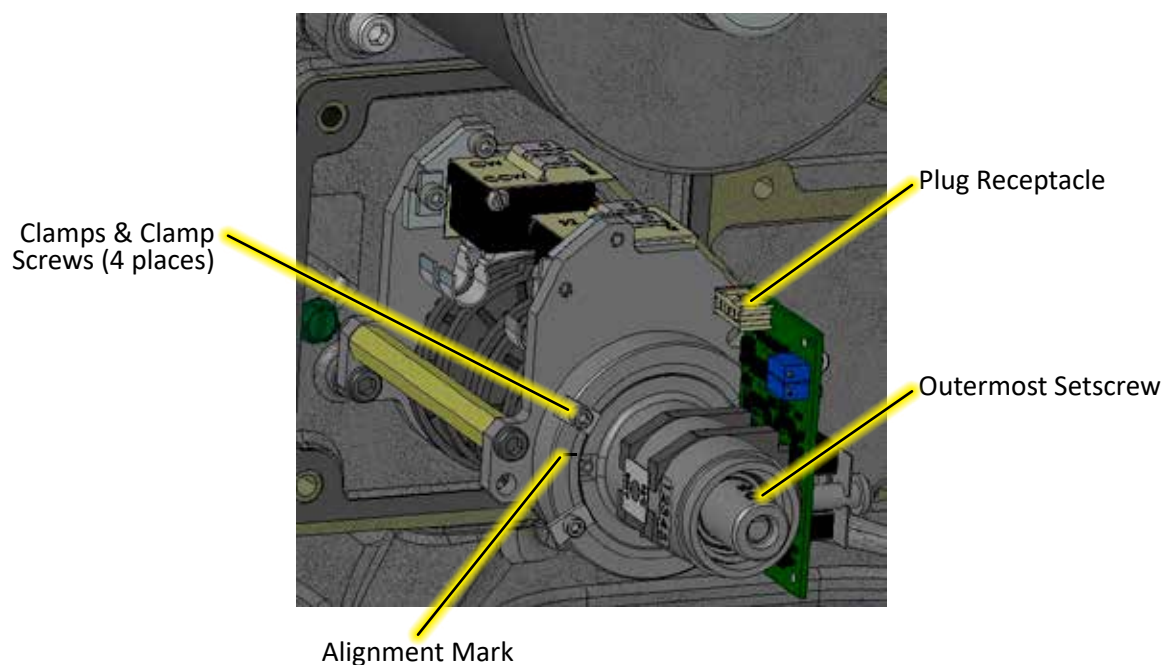

HANDSWITCH



WARNING

Electrical shock hazard. Disconnect power before proceeding.

REMOVE THE EXISTING HANDSWITCH:

1. Remove power from the actuator.
2. Loosen the two captive, socket head cap screws (3/16" hex wrench) on the Handswitch cover. Gently pull the cover and Handswitch assembly away from the actuator until the Handswitch wires are exposed.
3. Clip the five wires from the old Handswitch (removing any tie wraps or sleeving that may interfere).
4. Remove the Handswitch knob by loosening the two inset screws (5/64" hex wrench).
5. Remove the threaded bushing behind the Handswitch knob. The remaining Handswitch assembly components may now be removed from the Handswitch cover.



Captive Handswitch Cover
Screws (2 places)

INSTALL THE NEW HANDSWITCH:

6. Insert the new threaded bushing through the Handswitch cover onto the shaft, then attach the components leading to the switch as shown in the illustration below.
7. Place the seal in the bushing, then insert the knob over the bushing. Tighten the two inset screws to 3 lb-ft (4 N•m).
8. Splice the wires from the new Handswitch assembly to the wires from the actuator, color to color. Ensure the wiring is not exposed after splicing.
9. Replace the Handswitch cover. First, however, check the gasket for damage and replace, if necessary (see page 35). Tighten the captive screws to 6 lb-ft (8 N•m).

NOTE: When the Handswitch is turned fully clockwise, "AUTO" should be indicated. Be sure to place the tab on the tabbed washer into the slot in the actuator body to secure the Handswitch in place.

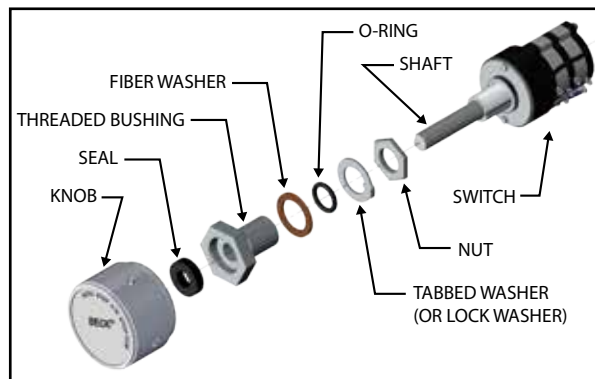

HANDSWITCH COMPONENTS

GASKETS

While performing any maintenance, inspect exposed gaskets for wear or damage. In order to protect internal components, worn or damaged gaskets should be replaced.

To remove existing gaskets, scrape all of the old gasket material and adhesive residue from the cover and actuator mating surface.

Standard Group 75 models are manufactured with self-adhering, silicone rubber gaskets. Peel the backing off of the replacement gasket and carefully apply to the actuator body.

MAINTENANCE

RECOMMENDED SPARE PARTS

A table of common, recommended spare parts is shown below:

Description	Part Number
Film Potentiometer Assembly	20-3060-11
Overtravel limit switch assembly (CW / CCW)	20-3200-06
Auxiliary switch assembly 2 switches (S1–S2) 4 switches (S1–S4)	12-8064-70 12-8064-71
Motor Assembly, Capacitor / Resistor Assembly	See Table Below
CPS-4, 2-Wire Assembly	20-3064-02
Gasket Replacement Kit	12-8064-24

If assistance is required in determining the spare part(s) needed, please contact Beck.

MOTORS & CAPACITOR/RESISTOR ASSEMBLIES

Motor							Capacitor / Resistor Assembly Part Number	Capacitor Value (μ f)	Resistor Value (Ω)
Part Number	Current (Amps)	Torque (N•m)	RPM	Frequency (Hertz)	Torque lb-ft [N•m]	Timing (sec./100°)			
NORMAL TEMPERATURE ACTUATOR MODELS									
20-2700-41	.17	0.5	72	60	40 [54]	40	14-2842-31	2	500
	.20		60	50		48	14-2842-30	3	500
20-2701-41	.31	1.0	72	60	80 [108]	40	14-2842-33	4	475
	.37		60	50		48	14-2842-32	6	360
20-2701-72	.45	1.0	120	60	80 [108]	24	14-2842-35	5	220
	.54		100	50		28.8	14-2842-34	6	220
OPTIONAL HIGH TEMPERATURE ACTUATOR MODELS									
20-2700-40	.17	0.5	72	60	40 [54]	40	14-2842-41	2	500
	.20		60	50		48	14-2842-40	3	500
20-2701-40	.31	1.0	72	60	80 [108]	40	14-2842-43	4	475
	.37		60	50		48	14-2842-42	6	360
20-2701-71	.45	1.0	120	60	80 [108]	24	14-2842-45	5	220
	.54		100	50		28.8	14-2842-44	6	220

NOTE: All motors listed are rated at 120 V ac.

TROUBLESHOOTING

CONDITIONS	POSSIBLE CAUSES	CORRECTIONS
1. Actuator will not hold position with Handswitch in STOP.	a. Self Locking Mechanism (SLM) is worn or damaged.	a. Rebuild the SLM assembly.
2. Motor runs, but the output shaft does not move in one or both directions.	a. Self Locking Mechanism (SLM) has failed.	a. Rebuild the SLM assembly.
3. Output shaft rotates opposite of desired direction.	a. The rotation direction is incorrectly configured.	a. Change the direction of rotation (see page 22).
4. Motor erratic.	a. Motor winding is open. b. Motor capacitor is shorted or open. c. Motor resistor is open.	a. Replace motor assembly. b. Replace capacitor. c. Replace resistor assembly.
5. Actuator will not run in either direction or one direction using Handswitch.	a. Over-travel limit switch failure. b. Handswitch failure.	a. Replace over-travel limit switch assembly (CW/CCW). b. Replace Handswitch assembly.
6. Actuator does not stop at normal or desired limit of shaft travel.	a. Limit switches set incorrectly. b. Over-travel limit switch failure.	a. Readjust the limit switches. b. Replace the over-travel limit switch assembly (CW/CCW).

INDEX

Actuator Options	8–9	Outline Dimension Drawings	6–7
Applications Reviews.....	39	Position Feedback Signal Calibration.....	23–25
Auxiliary Limit Switches	18, 21, 32	Power Quality	15
Setting Switches	21	Precautionary Information	10
Components	5	Product Demonstrations	40
Configuration/Calibration	20–21	Recommended Spare Parts	36
Contactless Position Sensor (CPS-4)..	19, 25, 34	Safety Precautions	10
Control Options.....	18	Self-Locking Mechanism (SLM).....	18, 28–29
Direction of Output Shaft Rotation.....	22	Services	39
Film Potentiometer	19, 23–24, 33	Site Surveys	39
General Specifications.....	4–5	Specification Writing	39
Handswitch	18, 35	Start-up.....	19
Handwheel.....	18	Storage Information	10
How to Obtain Service.....	39	Table of Contents.....	3
Installation	11–17	Terminal Connections	16
Electrical	15	Travel.....	22
Mechanical	11–14	Change Travel	22
Valves	11	Troubleshooting	37
Linkage	12–14	Warranty Statement.....	39
Linkage Requirements.....	12	Wiring Diagrams	16–17
Link-Assist™	13		
Mounting.....	11		
Wiring	16–17		
Introduction.....	2		
Limit Switches.....	18, 20–21, 32		
Setting Switches	20–21		
Linkage Kits	13		
Maintenance	26–36		
Motor Assembly	18, 26		
Motor Capacitor & Resistor Assembly	26–27, 36		

SERVICES

PRODUCT DEMONSTRATIONS

Each of Beck's Sales Engineers has access to a complete set of actuator models so that he can demonstrate virtually any of their features at your location. In order to arrange to see a Beck actuator in your plant or office, contact Beck's Sales Department.

SITE SURVEYS

Beck Sales Engineers are available to discuss your process control requirements. Often a visit to your location is the best way to gain a thorough understanding of your needs, in order to meet them most accurately and completely.

Mounting hardware, torque requirements, linkage, control signal information, and optional equipment can be analyzed most effectively at the work site. Beck's analysis at the job site can help ensure that specifications are accurate, especially in the case of complex applications.

APPLICATION REVIEWS

By sharing your needs with a Beck Sales Engineer you can take advantage of the best application advice for the type of control you need.

This review will yield a better understanding of the versatility of Beck actuators for your installations, as well as complete details on options and accessories to make the process as effective as possible.

SPECIFICATION WRITING

Beck provides specification writing assistance in order to help you specify and order the right actuators for your applications. Beck Sales Engineers will work with you to make it easier for you to obtain the proper equipment and give you confidence that no details are overlooked.

HOW TO OBTAIN SERVICE

Factory repair of actuators or subassemblies is available for both normal and emergency service. To assure prompt processing, contact the factory to receive a Returned Material Authorization (RMA) number. If a repair estimation is desired, please send the name and phone number of your contact for service authorization. It is helpful to include a description of the work desired with the shipment or, in the event of a problem, the malfunction being experienced.

THREE YEAR LIMITED WARRANTY STATEMENT*

Harold Beck & Sons, Inc. (Beck) warrants that our equipment shall conform to Beck's standard specifications. Beck warrants said equipment to be free from defects in materials and workmanship. This warranty applies to normal recommended use and service for three years from the date on which the equipment is shipped. Improper installation, misuse, improper maintenance, and normal wear and tear are not covered.

The Buyer must notify Beck of any warranty issues within 37 months of original shipment date and return the goods in question, at Buyer's expense, to Beck for evaluation. If the product fails to conform to the warranty, Beck's sole obligation and the Buyer's exclusive remedy will be: 1) the repair or replacement, without charge, at Beck's factory, of any defective equipment covered by this warranty, or 2) at Beck's option, a full refund of the purchase price. In no event will Beck's liability exceed the contract price for the goods claimed to be defective.

THIS WARRANTY IS EXPRESSLY IN LIEU OF ANY OTHER EXPRESS OR IMPLIED WARRANTY, INCLUDING IMPLIED WARRANTIES OF MERCHANTABILITY AND FITNESS FOR A PARTICULAR PURPOSE, AND ALL OTHER OBLIGATIONS OR LIABILITIES OF BECK. In no case shall Beck be liable for any special, incidental or consequential damages based upon breach of warranty, breach of contract, negligence, strict tort, or any other legal theory. Such damages include, but are not limited to, loss of profits, loss of revenue, loss of use of the equipment or any associated equipment, cost of capital, cost of any substitute equipment, facilities or service, downtime, the claims of third parties including customers and injury to property.

Buyer acknowledges its responsibilities under OSHA, related laws and regulations, and other safety laws, regulations, standards, practices or recommendations that are principally directed to the use of equipment in its operating environment. Buyer acknowledges that the conditions under which the equipment will be used, its use or combination with, or proximity to, other equipment, and other circumstances of the operation of such equipment are matters beyond Beck's control. **Buyer hereby agrees to indemnify Beck against all claims, damages, costs or liabilities (including but not limited to, attorney's fees and other legal expenses), whether on account of negligence or otherwise, except those claims based solely upon the negligence of Beck and those claims asserted by Beck's employees which arise out of or result from the operation or use of the equipment by Beck's employees.**

*Note: Internal water damage is not covered by warranty.

A 100% EMPLOYEE OWNED COMPANY

BECK

~ founded 1936 ~

SINCE 2021



HAROLD BECK & SONS, INC.

11 TERRY DRIVE • NEWTOWN, PENNSYLVANIA 18940 • USA

PHONE: 215-968-4600 • FAX: 215-860-6383 • E-MAIL: sales@haroldbeck.com

www.haroldbeck.com

Made in USA

