

BECK[®]

INSTRUCTION MANUAL



INTRODUCTION

This manual contains the information needed to install, operate, and maintain Beck Group 57 actuators equipped with the Digital Control Module (DCM), manufactured by Harold Beck & Sons, Inc. of Newtown, Pennsylvania.

The Group 57 actuator is a compact, powerful control package designed to provide precise position control of industrial valves requiring up to 250 lb-ft (339 N•m) of actuator torque.



IMPORTANT: This manual contains information that will make installation simple, efficient, and trouble-free. Please read and understand the appropriate sections in this manual before attempting to install or operate your actuator.



Group 75 compact rotary actuators ...

incorporate a very compact design with high temperature resistance and great mounting flexibility; making these actuators ideal for boiler windbox applications as well as all types of rotary valve applications in tight spaces.



Group 42 linear actuators ...

incorporate a long stroke design providing up to 1,000 lbs. (4450 N) of thrust. These actuators are ideally suited for burner air register type applications.



Group 22 digital actuators

Designed for accurate, reliable, modulating digital control of high torque applications. The actuator is ideal for use in large boiler applications, such as ID/FD fan dampers.



Group 11 rotary actuators

Provide precise position control of dampers, quarter-turn valves, fluid couplings, and other devices requiring up to 1,800 lb-ft (2 440 N•m) of torque.



Group 29 linear valve actuators

Ideally suited for globe valves from 1" to 8" (25 mm to 203 mm) diameter. Beck's unique Tight-Seater™ coupling provides positive seating of valves.



Group 31 compact rotary actuators

Particularly suited for coupling to ball, plug, and butterfly valves up to 4" (102 mm) diameter, and small dampers.

TABLE OF CONTENTS

Introduction	2
General Specifications	4
External Features	6
Outline Dimension Drawings	7
Precautionary Information	8
General Operation Information	9
Installation	10
Mechanical	10
Electrical	11
Wiring	12
Start-up Checklist	12
Electronics	14
Configuration/Calibration	21
Maintenance	40
Troubleshooting	49
Appendices	53
HART®	53
Serial	63
Optional Backup Power Unit	73
Modbus RTU	79
Optional Modbus TCP	113
Optional Wi-Fi	117
Index	118
Services	119

GENERAL SPECIFICATIONS

Actuator	12–30 Vdc (Standard) 12–48 Vdc (optional w/ power conditioner)	Allowable Tolerance								+10% -15%
Power	120, 208, 240, 380, 400, 415, 480, 575 Vac (Optional)									
Supply/Input Voltage	12–30 Vdc	120 Vac	208 Vac	240 Vac	380 Vac	400 Vac	415 Vac	480 Vac	575 Vac	
Power/Current Draw	100W, 8A	1A	0.6A	0.5A	0.3A	0.3A	0.3A	0.3A	0.2A	
Operating Conditions	-50° to 85°C (-58° to 185°F) BPU equipped actuators: -40° to 60°C (-40° to 140°F) 0 to 100% relative humidity, non-condensing									
Torque Output	57-109 -- 120 lb-ft (163 N•m) 57-209 -- 250 lb-ft (339 N•m)									
Stroke Timing	57-109 -- 9 seconds per 90° (configurable for slower speeds) 57-209 -- 14 seconds per 90° (configurable for slower speeds); Vdc 20 seconds per 90° (configurable for slower speeds); Vac									
Communication Interface	HART protocol (Rev. 5—burst mode is not supported) Pushbutton / LEDs DB9 Serial commands Modbus RTU (TCP optional) Wi-Fi (optional)									
Demand Input Signal	4–20 mA signal, ac or dc pulses									
Minimum Step Size	0.1°									
Hysteresis	0.25% of span at any point									
Demand Input Signal Characterization	<p>Linear: Actuator output shaft moves proportionally to the input signal.</p> <p>Square: Actuator output shaft moves proportionally to the square of the input signal.</p> <p>Square Root: Actuator output shaft moves proportionally to the square root of the input signal.</p> <p>Custom: Actuator output shaft moves according to the configurable 20-segment (maximum) response curve.</p>									
Position Feedback Signal	4–20 mA or 1–5 Vdc (standard)									
Isolation	Isolation: Demand input and position Feedback signals are isolated from ground and the AC or DC power line. Signal buffering provides 24 V dc isolation between the Demand and Feedback signals									
Position Status Indication	Configurable LEDs (red, green & yellow) visible through optional terminal compartment window (see page 71 for description). Digital numeric LED position display as a percentage of travel (optional).									
Action on Loss of Power	Stays in place. Optional: Fail-to-safe position with integral Backup Power Unit.									
Action on Loss of Input Signal	Stays in place or drives to any preset position (configurable).									

Stall Protection	If the motor tries to run in one direction for more than 300 seconds (configurable from 30 to 450 seconds), the DCM will shut off power to the motor (feature can be enabled/disabled)—factory default is enabled.
Overtorque Protection (optional)	The DCM shuts off power to the motor if the measured output torque of the actuator exceeds 115% (adjustable from 25% to 115%) of the actuator rating (feature can be enabled/disabled)—disabled is the factory default.
Over-travel Limit Switches	Two cam-operated switches (CW and CCW) provide over-travel protection.
Auxiliary Switches	Up to four (two standard) Form A or B mechanical switches available, rated 10A, 125/250 Vac; .5A, 125 Vdc; .25A, 250 Vdc. See page 23 for a switch-setting diagram and factory default settings.
Relays (programmable)	Three field configurable SPST solid state relays are standard for the indication of: Relay #1 - actuator status Relay #2 - actuator status or output shaft position Relay #3 - actuator status or output shaft position Rating: 120 Vac/Vdc, 80 mA max. Optional interposing electro-mechanical relays: Two SPDT relays that act as interposing relays to boost the voltage and current capacity of Relays #2 and #3. Rating: 250 Vac, 3A max., 30 Vdc, 3A max.
Lockable Handswitch	Permits local electrical operation independent of controller signal (Standard). May be locked in any position to prevent local operation. Auto indication is available at terminals 12–14 (28 Vdc max.; 125 mA max.).
Hand Crank	Provides manual operation without electrical power.
Motor Assembly	Does not coast or overshoot and will not overheat—even under continuous modulation. Motor overtemperature sensing is not needed because Beck motors will not overheat.
Gear Train	High-efficiency, precision-cut, heat-treated alloy steel and ductile iron spur gears.
Mechanical Stops	Internal, fixed (standard).
Enclosures	Precision-machined, aluminum alloy castings painted with corrosion-resistant polyurethane paint provide rugged, dust-tight, weatherproof enclosures. Type 4X; IP66 / IP68, 3 meters/48 hours*. *Internal water damage is not covered by warranty.
Output Shaft Rotation	90 degrees (nominal)
Mounting Orientation	Any orientation—no limitations.
Electrical Safety Certification	CSA labeled (US & Canada)
Hazardous location approvals are available:	
<u>North American</u>	
Class I, Div. 1, Groups B, C, & D; T4A	
Class I, Zone 1, IIB + H2; T4A	
Class II, Div. 1, Groups E, F, & G	
Class III, Div. 1	
T ambient = -50°C to 85°C (-58°F to 185°F)	

EXTERNAL FEATURES

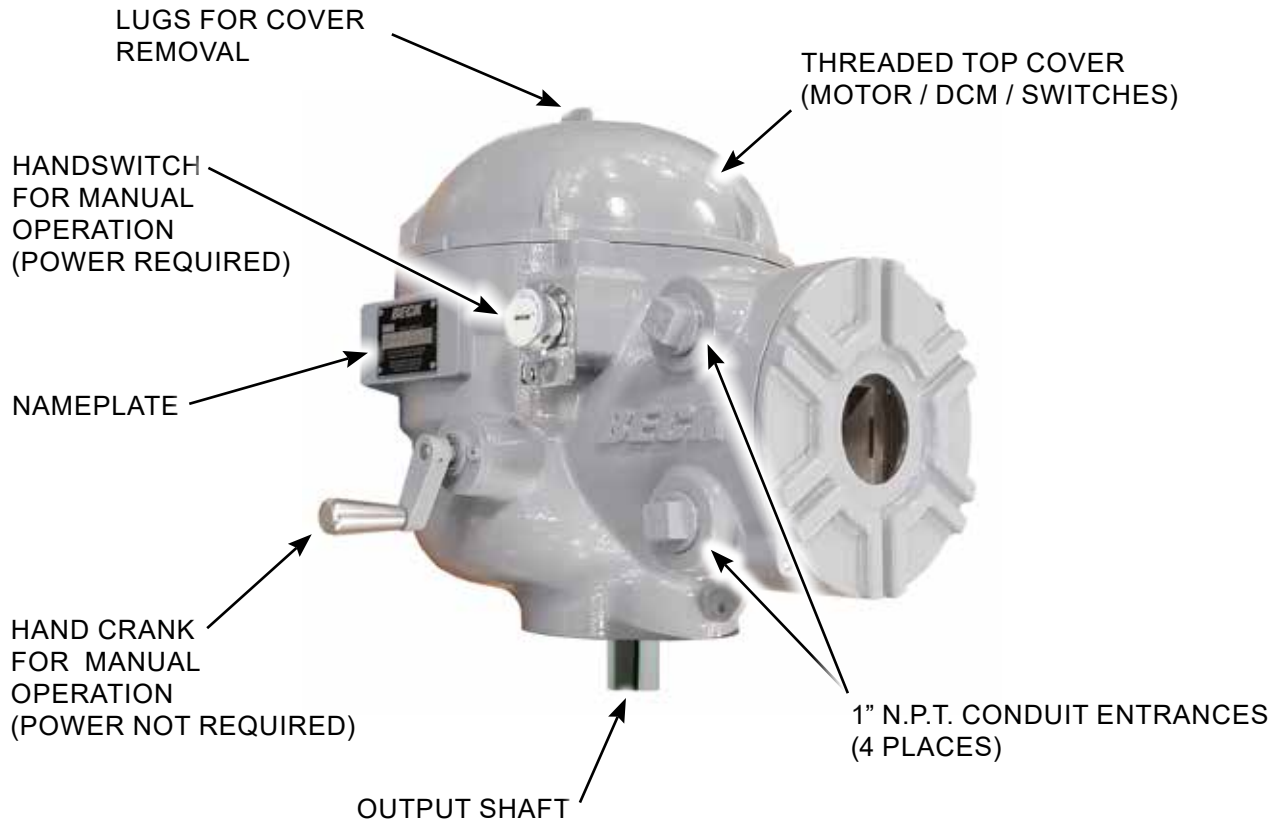

Model No.	Approx. Weight	Rated Torque	Max. Overhung Load
57-109	59 lbs. 27 kgs.	120 lb-ft 163 N•m	750 lbs. 340 kgs.
57-209	85 lbs. 39 kgs.	250 lb-ft 339 N•m	3,000 lbs. 1,361 kgs.

DIRECT MOUNT FASTENER GUIDE

	Size (in.)	Torque* lb-ft [N•m]
Coupling Screws	5/8-18	170 [230]
Actuator Mounting Screws	3/8-16	20 [27]

*May vary per application.

OUTLINE DIMENSIONS

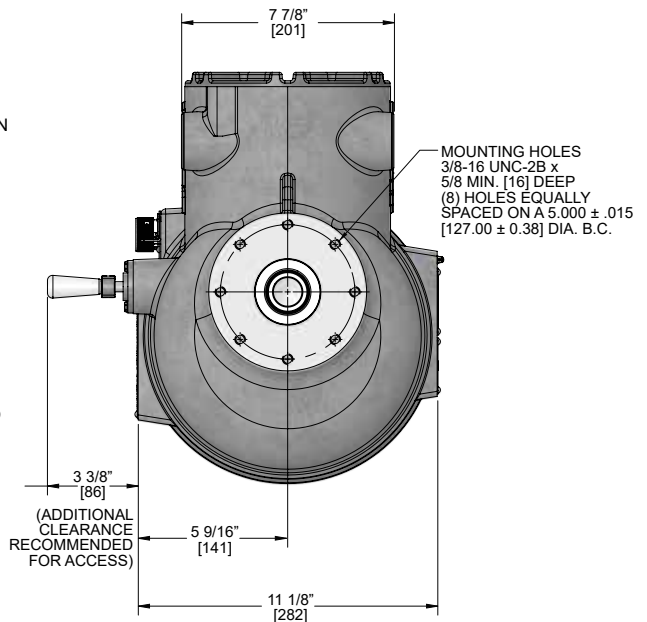
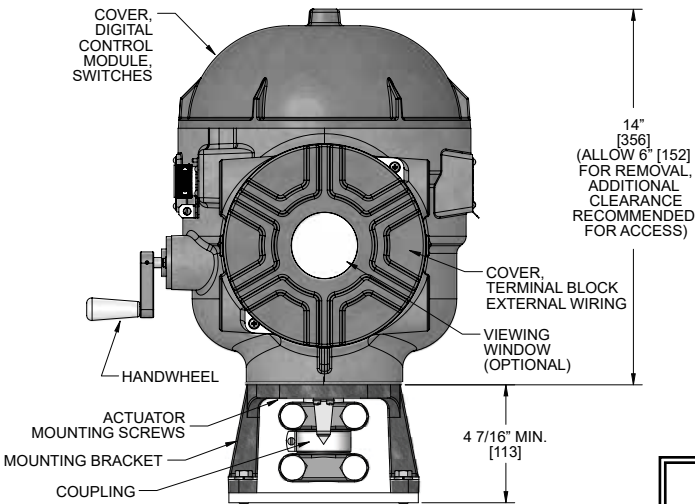
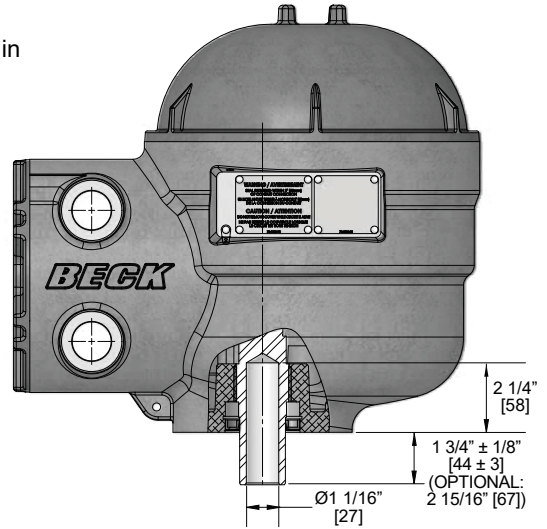
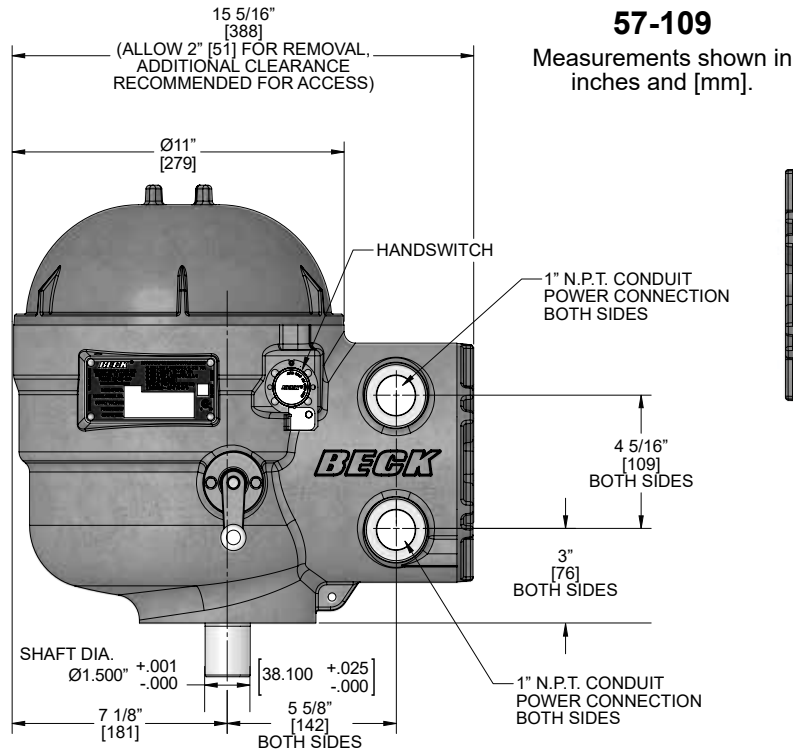

VALVE DIRECT MOUNT HARDWARE

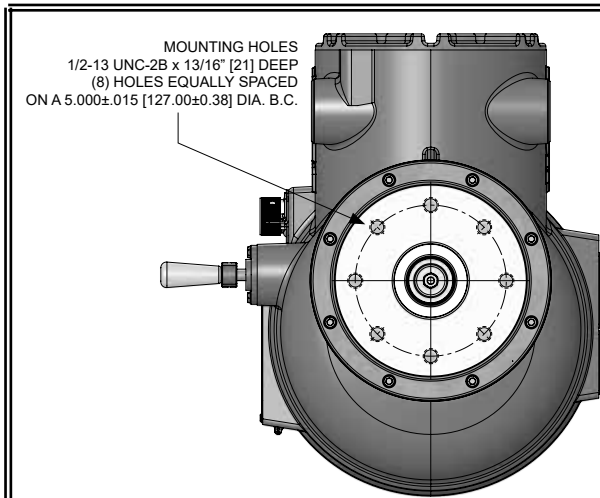

57-209 DIMENSIONAL DIFFERENCES

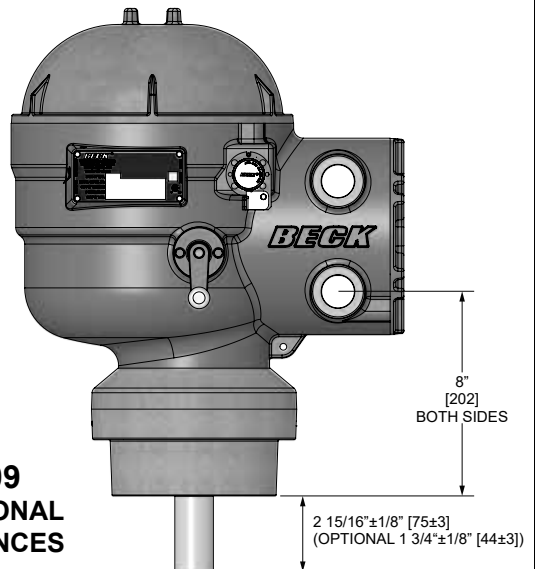

PRECAUTIONARY INFORMATION

STORAGE INFORMATION

Beck actuators should be stored in a clean, dry area where the temperature is between -50° and 85°C (-58° to 185°F).

Damage due to moisture while in storage is not covered by warranty.

SAFETY PRECAUTIONS



WARNING

Installation and service instructions are for use by qualified personnel only. To avoid injury and electric shock, do not perform any servicing other than that contained in this manual. Please read and understand the appropriate sections in this manual before attempting to install or operate your actuator.



CAUTION

For maximum safety, the Beck actuator body should be grounded. Use the green grounding screw in the wiring compartment of the actuator.



CAUTION

Always close covers immediately after installation or service to prevent moisture or other foreign matter from entering the actuator.



CAUTION

Conduit entrances are provided for power and signal wiring. Temporary plugs are installed in the conduit entrances at the factory for shipping only and are not intended for permanent use. Prior to actuator operation, all conduit entrances must be properly sealed in accordance with National Standards or Regulatory Authorities.

VALVE ACTUATOR INSTALLATIONS



CAUTION

Working with valves installed in a pipeline can be dangerous. Take appropriate precautions when mounting to installed valves.

GENERAL OPERATION INFORMATION

MODES OF OPERATION

There are three basic modes of operation:

- **Hand crank**—local mechanical control
- **Handswitch**—local electrical control
- **Automatic**—remote electrical control

Any or all of these modes can be used to test basic operation of your actuator during start-up.

HAND CRANK

The Hand crank permits manual operation of the actuator without power and is particularly useful during initial installation or when power is not available.

If power is available, the Handswitch must be moved to the STOP position before manually operating the Hand crank.

HAND CRANK



LOCKABLE HANDSWITCH

A Handswitch allows local electric control at the actuator. In either of the STOP positions, the motor is blocked from running. In the CW or CCW positions, the motor runs to move the output shaft in the corresponding direction. When moving the output shaft using the Handswitch, the motor will stop when the over-travel limit switches are reached. The Handswitch may be locked in any position to prevent local control.



The Demand signal (or Modbus setpoint) can position the actuator only when the Handswitch is in the AUTO position.

AUTOMATIC MODE

When the Handswitch is placed in the AUTO position, the actuator is in automatic mode and responds to a Demand signal (also called the setpoint). The Digital Control Module (DCM) compares the Demand signal with the output shaft position. When the DCM detects a difference between Demand and Position (referred to as error), the motor will rotate the output shaft until the Position matches the Demand.

Pulsed control: If desired, the actuator can alternatively be pulsed when in the AUTO Handswitch mode. This requires the use of either the dry contact control override inputs or the pulsed Vac control override inputs (see the wiring diagram on page 13).

INSTALLATION Mechanical

Beck Group 57 actuators may be installed in any convenient orientation, because the gearing does not require an oil bath. Refer to the outline dimension drawings for physical dimensions and required clearances.

VALVE ACTUATOR INSTALLATIONS



CAUTION

Working with valves installed in a pipeline can be dangerous. Take appropriate precautions when mounting to installed valves.

Whenever an actuator is being mounted on a valve, refer to the valve manufacturer's maintenance manual for specific valve-related instructions. Consult the Beck Valve Mounting Specification sheet shipped with the actuator for specific instructions on assembly of the Beck actuator and mounting hardware to the valve. It is good practice to remove the valve from service, if possible.

UNITIZED VALVE/ACTUATOR ASSEMBLY INSTALLATION

Inspect the valve and pipe flanges to ensure they are clean. Be certain that other pipelines in the area are free from pipe scale or welding slag that could damage the gasket surfaces.

Carefully lift the assembly and position the valve in the pipeline. Install and tighten the flange bolts according to the valve and/or gasket manufacturer's instructions.

NOTE: The valve may have undergone temperature variations in shipment. This could result in seepage past the stem seals. Refer to the valve manufacturer's maintenance instructions for packing adjustments, if required.

INSTALLATION Electrical

POWER QUALITY

Power quality disturbances such as power outages, transient voltages, harmonic distortions, and electrical noise will adversely affect your actuator performance. Protecting your actuator from these conditions can reduce downtime and promote longer life for the equipment. Following the industry-accepted standards below will help protect your actuator.

- ✦ Select wiring materials according to the correct ampacity ratings dictated by national and local regulations.
- ✦ Shielded, twisted pair cables can be used for signal connections to avoid being affected by electrical noise. These signal wires, based on Noise Susceptibility Level (NSL) per IEEE-518, fall into the level 1 classification. A braided shield will be more effective than a wrapped foil shield. Signal wire shields should be connected to the actuator casting grounding screw. If grounding at the signal source is required, then the shield should not be grounded at the actuator.
- ✦ Raceways such as conduits and trays must be grounded at both ends to properly meet immunity requirements.
- ✦ A power ground connection should be made between the power source and the Beck actuator. Grounding connections including wire and metal conduit are permitted, but the actuator-grounding conductor may not be connected to a structured metal frame of a building.
- ✦ Surge suppression equipment that meets Underwriters Laboratory (UL) Standard 1449 may be used to protect against transient voltage conditions.
- ✦ Power Conditioners may be used to regulate the supply voltage and maintain a constant voltage level. They are helpful in protection against voltage sags and swells, as well as some measure of electrical noise protection.
- ✦ Harmonic filters may be used to minimize the effects of supply voltage waveform distortions and are used in applications that incur a large amount of high-frequency electronic noise.
- ✦ For actuators using DC operating voltage, choose a size of wire that will minimize the voltage drop between the actuator and the power supply. Wire with larger cross-sectional area reduces voltage drop and improves actuator performance.

ELECTRICAL INSTALLATION

Four 1" N.P.T. conduit connections are provided for power and signal wiring to the actuator. Conduits should be routed from below the actuator so that condensation and other contaminants flow away from the conduit. All conduit entrances must be properly sealed in accordance with National Standards or Regulatory Authorities.

Power and signal wires should be routed to the actuator separately and be either shielded cables or installed in conductive conduit and/or cable trays.

Refer to the wiring diagram furnished with your Beck actuator for proper power and signal connections.

It is advisable to provide normal short circuit protection on the DC power line. A copy of the wiring diagram is shipped with each actuator inside the terminal compartment. If there is no wiring diagram available, you may obtain a copy from Beck by providing the Serial number of your actuator.

Connection of a 4–20 mA Demand signal should be made to terminals 36 (+) and 35 (–).

For maximum safety, the Beck actuator body should be grounded. Use the green grounding screw in the wiring compartment of the actuator.

TERMINAL SCREW TORQUES

Each terminal screw should be torqued to the proper specification upon landing the wire.

TERMINALS	TORQUE	
	(LB-IN)	(N•M)
1–3	16	1.8
4–27	12	1.4
28–41	12	1.4



CAUTION

Always close covers immediately after installation or service to prevent moisture or other foreign matter from entering the actuator.

INSTALLATION Wiring

TERMINAL CONNECTIONS

The terminal blocks are located in a separate, gasketed compartment behind a threaded cover at the front of the actuator. Line voltage connections are made on terminal designations 1 and 2 (on the bottom of the board - see drawing at right). Terminal 1 is AC line or DC (-) and terminal 2 is AC neutral or DC (+).

Terminal screws will accept standard spade or ring terminals. Terminals 4 through 41 accommodate #22 AWG and will accept #12–22 AWG (3.31–.326 mm²). Terminals 1 through 3 accommodate #18 AWG and will accept #8–18 AWG (8.36–.823 mm²). For wiring versatility, the screw-down clamp design will also accept unterminated wire.

Typical wiring connections are shown on the next page. Each actuator can be ordered with up to four optional auxiliary switches (wiring connections are described in the Configuration/Calibration section).

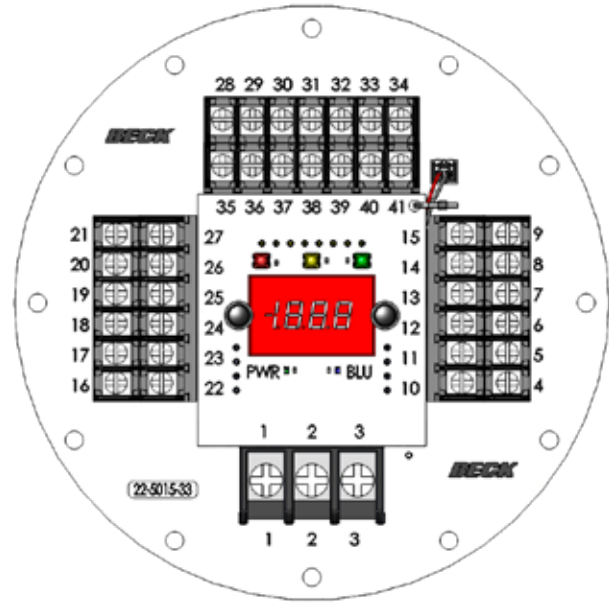

START-UP

NOTE: All Beck actuators are shipped from the factory ready for installation. Each actuator is set-up and calibrated to the customer's specifications that were written into the equipment order. Electrical adjustments are generally not required before placing the actuator in operation.

START-UP CHECKLIST

The following list provides some basic checks that should be performed before placing your actuator into operation.

- Inspect the location and the mounting surface.
- Confirm the actuator is receiving the appropriate operating voltage as shown on the nameplate.
- Check the green DCM Power LED. It should be pulsing (Dim/Bright) to indicate the board is active.
- Using the Handswitch, confirm the actuator moves fully to both the CW and CCW ends of travel.
- Confirm the actuator has a 4–20 mA Demand signal attached to terminals 36 (+) and 35 (–).
- Place the Handswitch in AUTO and vary your Demand signal from 0% to 100%.
- Check for the Status (“STAT”) alarm LED on the DCM. If it is lit, refer to the Troubleshooting section of this manual.
- Verify that the output shaft is moving to the desired 0% position with a 0% Demand signal and moving to the 100% position with a 100% Demand signal. If they are reversed, see the Configuration/Calibration section of this manual for instructions on how to change the direction of output shaft rotation.

TYPICAL WIRING CONNECTIONS

(Each actuator has a specific wiring diagram inside the terminal compartment)

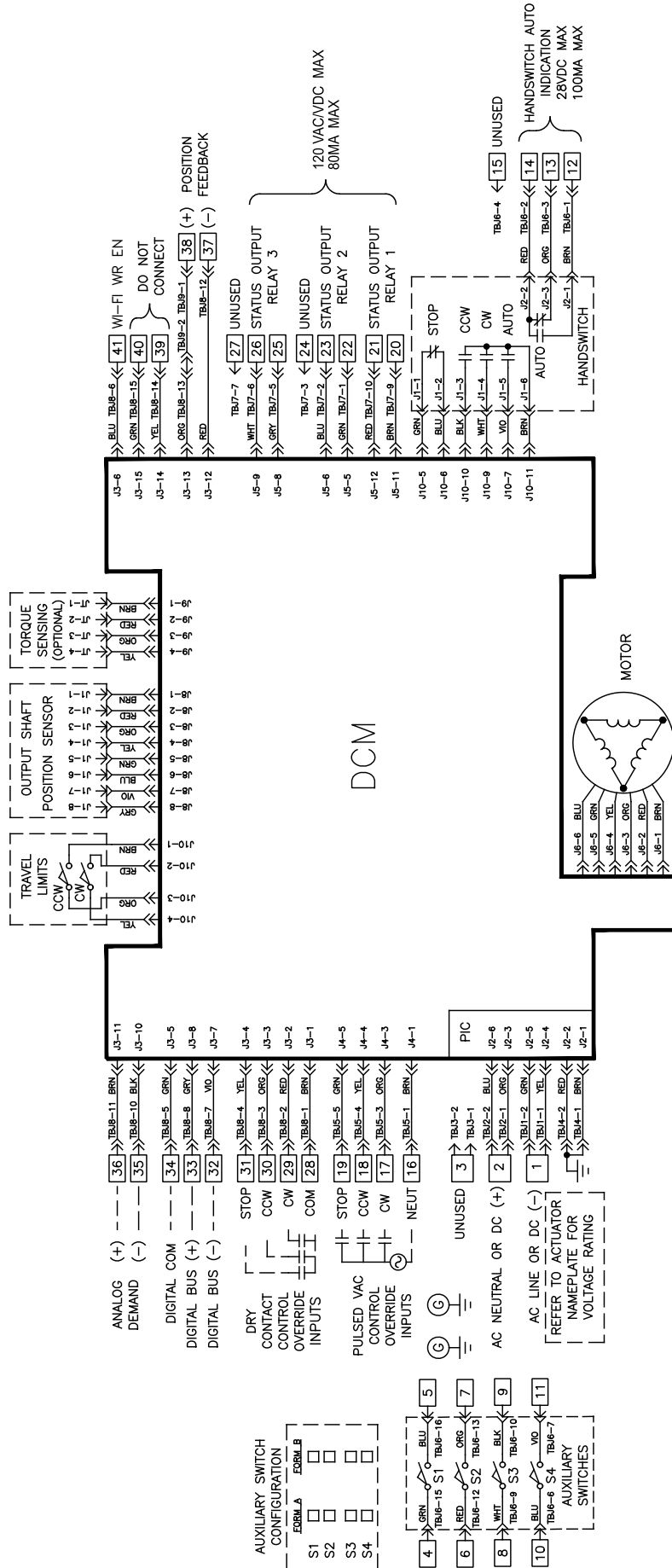

NOTES:

1. INPUT/FEEDBACK SIGNALS: ISA TYPE 4, CLASS U POWER ISOLATED
2. —#— CUSTOMER TERMINAL BLOCK

ELECTRONICS

CONTACTLESS (MAGNETIC VECTOR) POSITION SENSOR

Unlike the contactless position sensors used in other Beck actuators, the Group 57 actuator uses new technology that measures the output shaft position with magnetic vector sensing.

The Group 57 position sensor calculates the rotational angle of the output shaft by determining the direction of magnetic lines of flux passing through it. The sensor is a single, integrated circuit and has no mechanical adjustments.

The sensor continuously transmits the magnet vector angle to the DCM. The DCM then compares the sensor limit values with the live sensor reading to calculate the actual output shaft position.

If the sensor is ever replaced, the actuator should be recalibrated. The procedure for replacing and recalibrating the sensor is outlined in the Maintenance section of this manual on pages 45–46.

NOTE: HART and Serial commands sometimes refer to the position sensor as “CPS”.

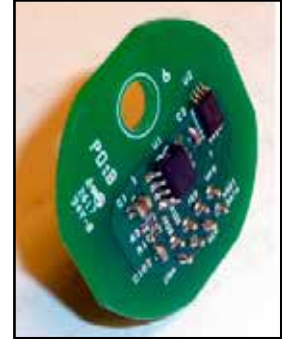

DIGITAL CONTROL MODULE (DCM)

The DCM is a micro-processor based circuit board assembly that serves as the actuator's control center.

The main function of the DCM is to position the actuator's output shaft. The DCM compares the Demand (either Analog 4–20 mA or Modbus setpoint) to the actuator position sensor reading. If

a difference exists between Demand and Position (the error), the DCM synthesizes the motor waveform that will move the output shaft (through the gear train) to correct the imbalance.

The DCM layout is illustrated on page 18 and shows the fuse and test point locations.

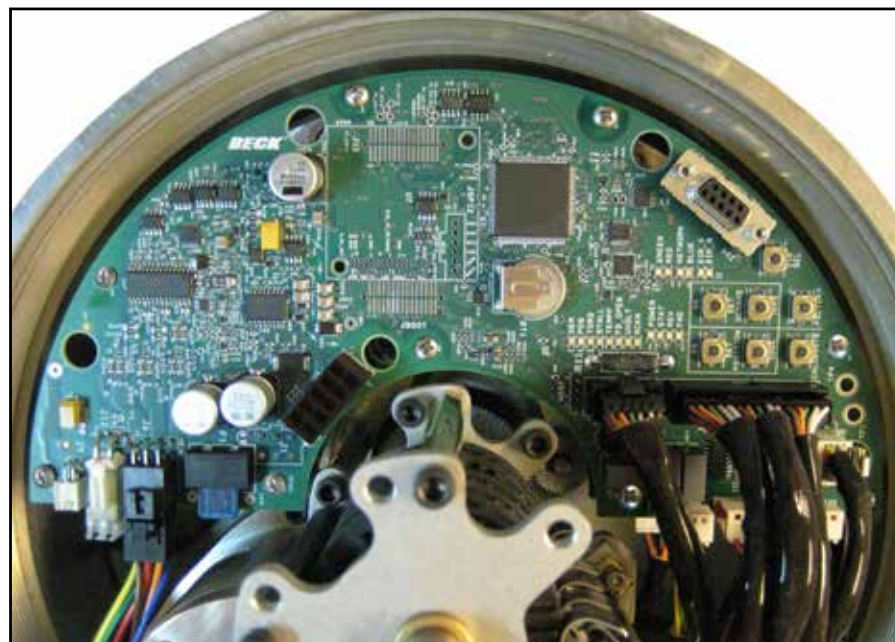

DCM CHASSIS TYPES

AC VERSION

The AC Version of the DCM chassis accepts the line voltage stipulated on the actuator nameplate and converts it to DC for operation of the electronics. The AC version has an integrated transformer and is wired to the terminal block using an AC chassis (white) power connector:

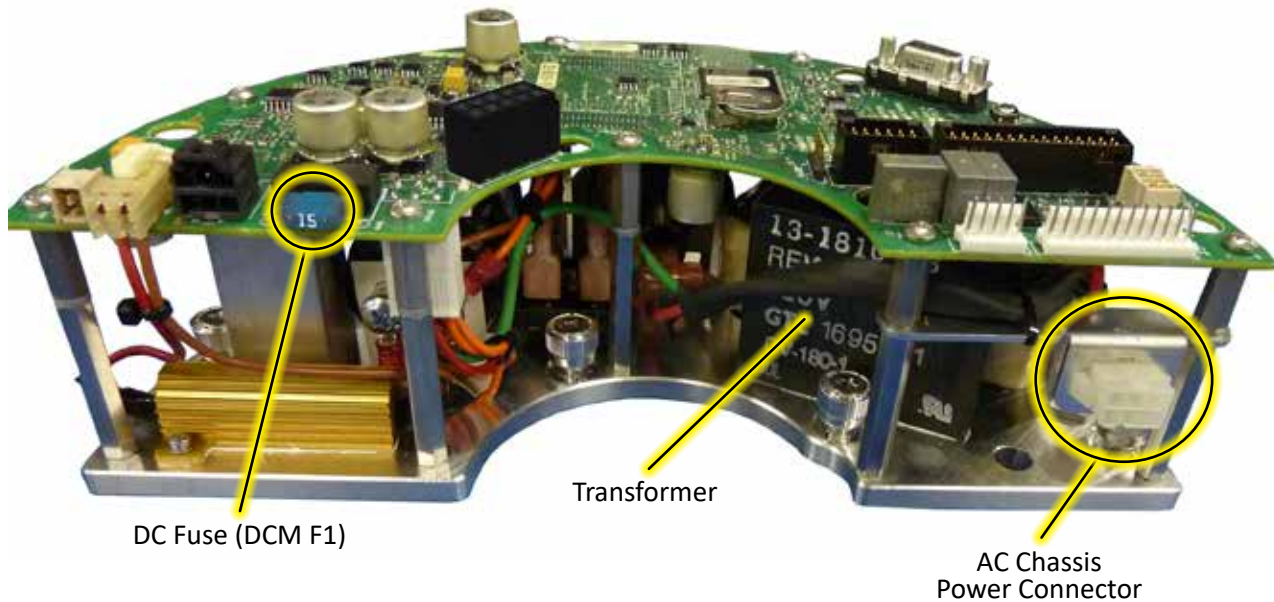

DC VERSION

The DC version of the DCM chassis has a transformer and is wired directly to the terminal block using a DC-type (black) connector:

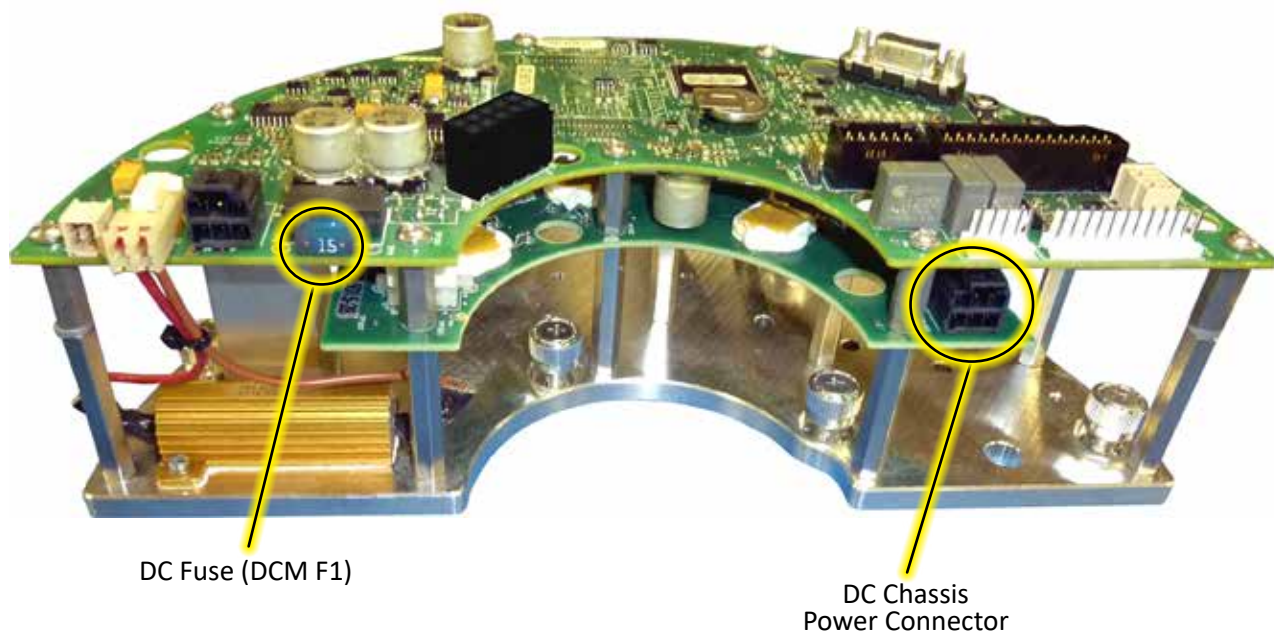

ELECTRONICS

DCM FUSE LOCATIONS

All DCM chassis types have a fuse located on the main circuit board at location F1. This fuse is a standard, blade-type fuse. The fuse should be replaced with the exact same part (see "COMMON RECOMMENDED SPARE PARTS" table on page 48).



"BLADE-TYPE" FUSE (TOP VIEW)

The AC version of the DCM Chassis has an additional fuse at the input to the transformer. This fuse provides additional protection to the actuator. The fuse should be replaced with the exact same part (see "COMMON RECOMMENDED SPARE PARTS" table on page 48).

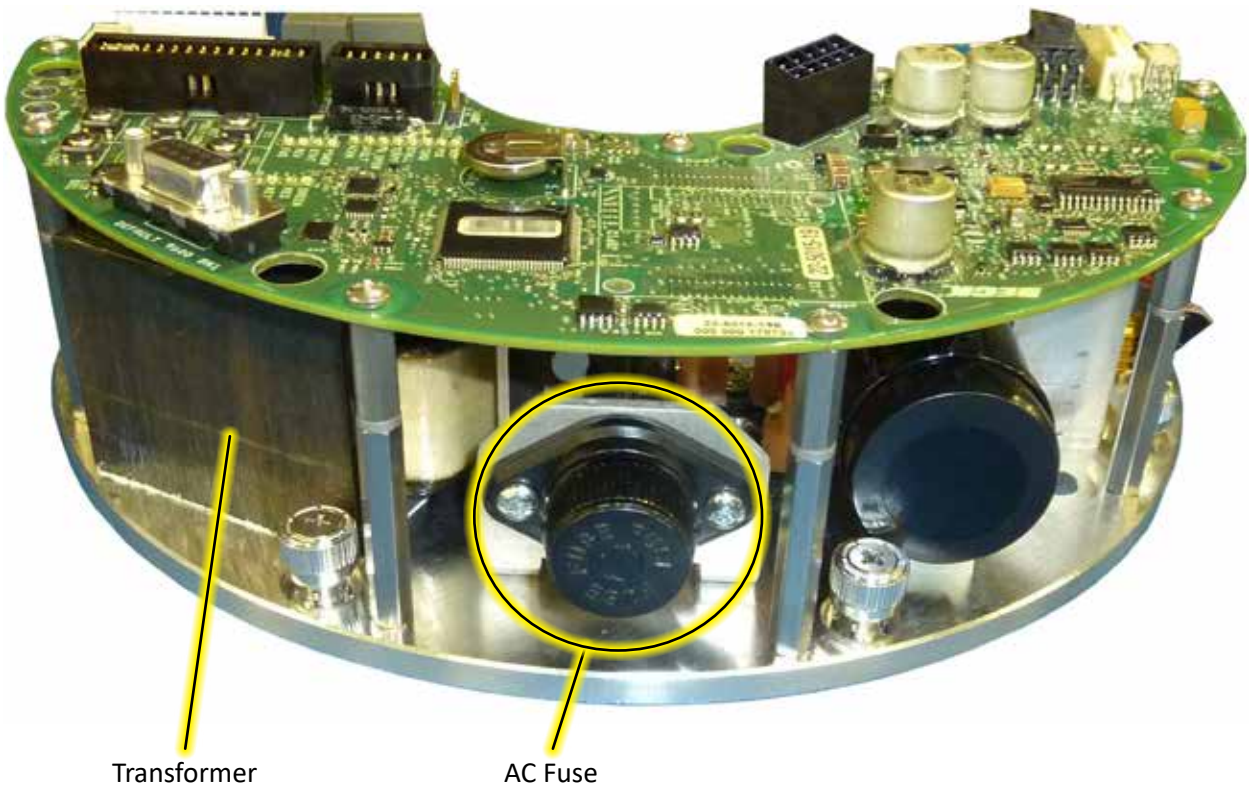

DCM SETUP AND CONFIGURATION INTERFACES

PUSH BUTTONS

The DCM board is equipped with push buttons that can be used to calibrate the Demand signal and configure 0% and 100% positions. It may also be used to configure the direction of output shaft rotation for increasing Demand or to return the DCM to its factory settings.

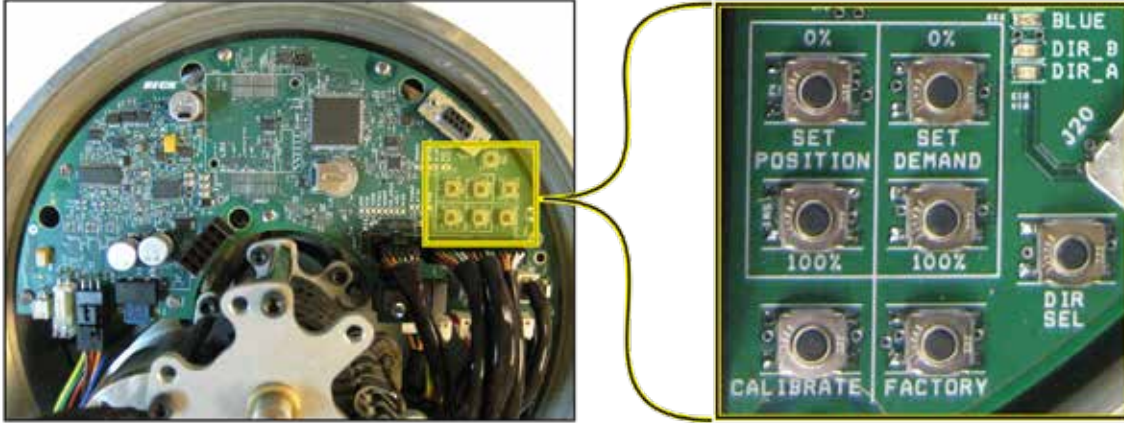

HART

The HART interface is accessible by connecting a HART capable communication device (such as a handheld communicator) to terminals 36 (+) and 35 (-) of the terminal block area. A HART-capable, analog output can be used for the Demand signal as well. All electronic calibration and configuration can be accomplished through the HART interface. NOTE: The appropriate HART device descriptions are required.

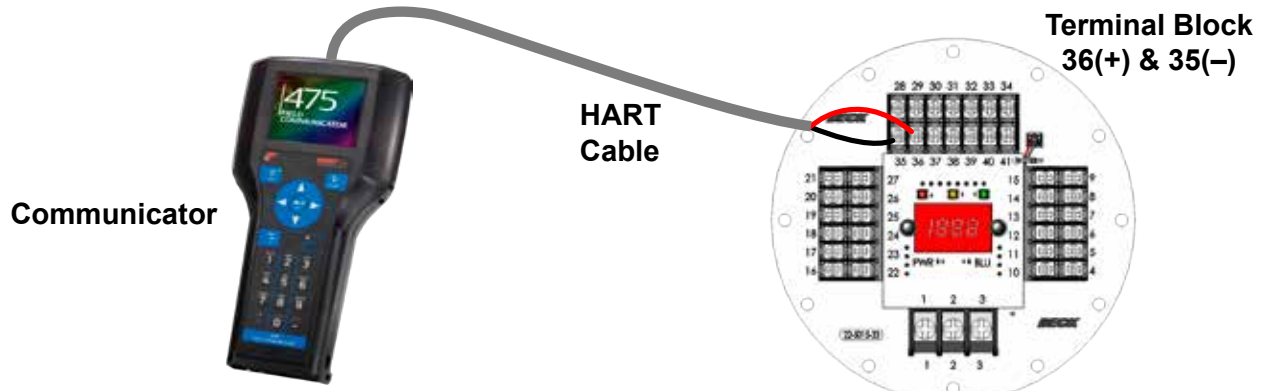

SERIAL PORT

The Serial port interface is accessible by connecting a computer to the DCM using the DB9 connector. See the Serial Communications appendix for details on connecting via the Serial port. All electronic calibration and configuration can be accomplished through the Serial port interface.



MODBUS

Modbus is included with the Group 57 actuator. For setup, configuration and details, see the instructions beginning on page 84. NOTE: Modbus is not an interface, but rather a digital control protocol designed for setup and configuration—there are no Device Descriptions or standardized tools for Modbus.

ELECTRONICS

DCM LAYOUT

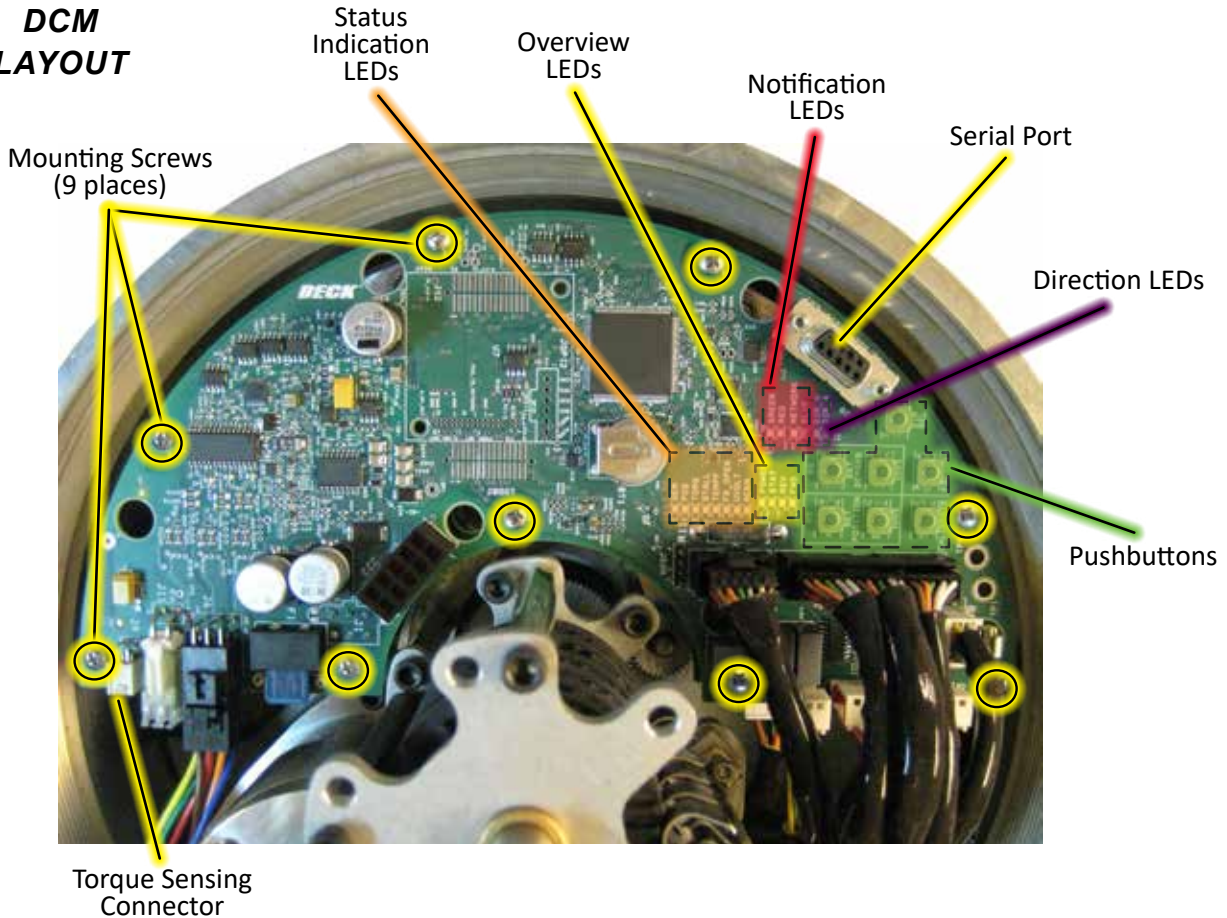

OVERVIEW LEDs

Located on the DCM board (pictured above), these LEDs indicate the basic, real-time state of the actuator. A description of each LED follows.

POWER

This green LED illuminates when power is applied to the actuator. This LED pulses from bright to dim indicating the DCM is operational.

STAT

This red LED illuminates during a system alarm (see Status Indication LEDs, next page). Explanation of the specific alarm is available through the Modbus or Serial interface. See the Troubleshooting section for additional information.

REV

This green LED illuminates when the actuator is receiving a Demand signal less than its position.

FWD

This green LED illuminates when the actuator is receiving a Demand signal greater than its position.



NOTIFICATION LEDs

GREEN & RED

Indicates the position of the actuator (see page 71, mimics the lights on the terminal board).

NETWORK

This green LED pulses when a MODBUS message is received.

BLUE

This blue LED light mimics the light on the terminal board (currently unused).

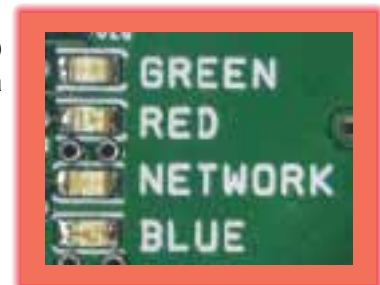

DIRECTION LEDs

These green LEDs indicate the direction of travel resulting from an increasing Demand signal.



A = CCW B = CW

STATUS INDICATION LEDs

When the “STAT” LED is lit, a red indication LED(s) will light to reveal the actuator condition(s). An alarm is available at terminals 20 & 21. When the condition is corrected, the status will automatically reset.

DEM

Loss of the Demand input signal.

POS

The Position signal to the DCM is out of the calibrated range limits. The lower limit is -5% and the upper limit is 115% of the calibrated range. May also indicate an internal wiring failure.

TORQ

This LED indicates that excessive torque is present (over 105% of the actuator rating).

STALL

The actuator is in a stall condition and stall protection has been activated.

TEMPF

Actuator's internal temperature is outside of rating.

FB_OPEN

External position Feedback signal is enabled, but not wired to an external load or the wiring has failed between the actuator and the monitoring device.

UVOLT

Operating voltage is too low for the actuator to function properly.

ACKN

Acknowledges when a calibration procedure has been completed.

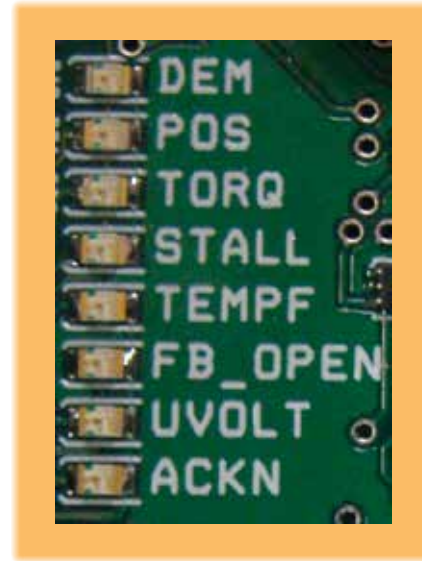

STATUS INDICATION LEDs

PUSHBUTTON CONTROLS

The seven pushbuttons (pictured below) on the DCM are used for calibration. When pressing a pushbutton, pressure should be maintained until the “ACKN” LED is lit; this confirms receipt of the pushbutton command. See the Configuration/Calibration section of this manual for further explanation of calibration procedures.

CALIBRATE

This button must be pressed and held simultaneously with another pushbutton to perform a calibration.



CAUTION

Pressing the following buttons may change calibration and cause the actuator to reposition.

SET POSITION 100%

Press to designate the current position of the output shaft as the 100% position for actuator movement (this will correspond to a 100% Demand signal).

SET POSITION 0%

Press to designate the current position of the output shaft as the 0% position for actuator movement (this will correspond to a 0% Demand signal).

SET DEMAND 100%

Press to designate the current analog Demand input signal as 100% Demand.

SET DEMAND 0%

Press to designate the current analog Demand input signal as 0% Demand.

DIR SEL

Press to change the direction in which the output shaft will rotate in response to an increasing Demand signal.

FACTORY

Press to reset calibration to the factory settings.

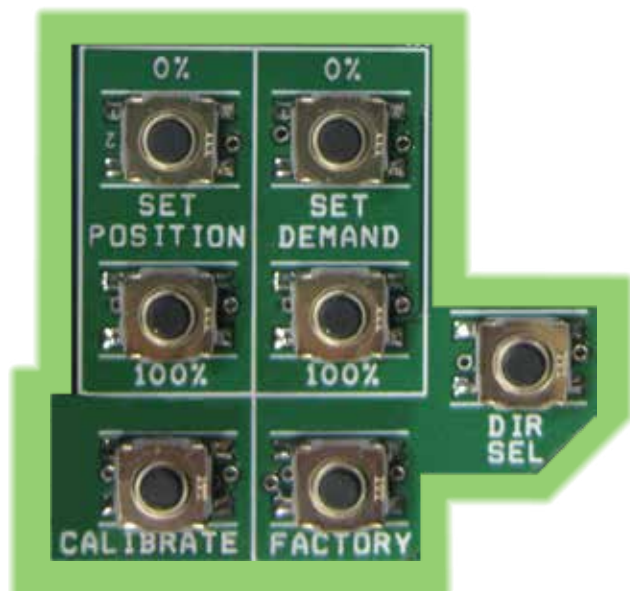

PUSHBUTTON CONTROLS

ELECTRONICS

SIGNAL TEST POINTS

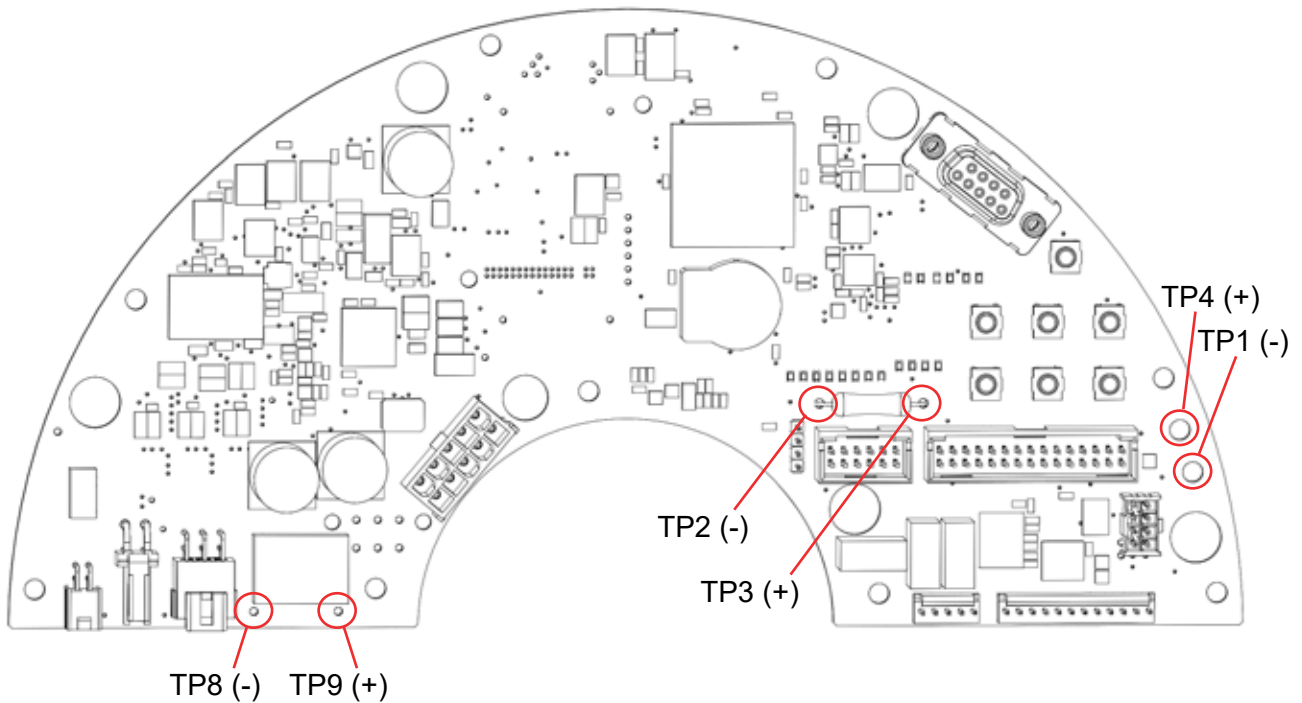

SIGNAL TEST POINT PAIRS

TEST POINT PAIR	SIGNAL DESCRIPTION	EXPECTED RANGE
TP3 (+) and TP2 (-)	Demand Analog Signal. The actual analog Demand current converted to a voltage drop across a precision 250 Ω resistor.	1.0–5.0 Vdc (linear). At 4 mA Demand, the voltage will equal 1.0 Vdc. At 12 mA Demand, the voltage will equal 3.0 Vdc. At 20 mA Demand, the voltage will equal 5.0 Vdc.
TP4 (+) and TP1 (-)	Position Sensor Analog Signal. A voltage that represents the percentage open scaled from one to five volts.	1.0–5.0 Vdc (linear). At 0% shaft position, TP4 equals 1.0 Vdc. At 50% position, TP4 equals 3.0 Vdc. At 100% shaft position, TP4 equals 5.0 Vdc.
TP9 (+) and TP8 (-)	Main DC Bus. The actual DC voltage supplied to the DCM.	11.0–32.0 Vdc (fluctuates). For AC models, this voltage is generated by the built-in power supply. This voltage should be above 11.0 Vdc and below 32.0 Vdc. Voltage may fluctuate while the actuator is running.

CONFIGURATION/CALIBRATION

COVER REMOVAL

TOP COVER

Access to the actuator's electronics and switches requires removal of the threaded top cover. For all subsequent configuration and calibration instructions, remove the top cover by first locating the cross recessed pan head screw located above the Handswitch (see below). This screw is designed to help hold the cover in place. Tighten this screw until it is flush with its base and no longer touching the rim of the cover (5 lb-in (.5 N•m)).



Next, unscrew the top cover from the actuator body (see image below). To loosen, place the shaft of a large screwdriver between the lugs on top of the cover and twist counterclockwise. Replace the cover in the same way by hand-tightening using the shaft of the screwdriver until the rim is flush with the body (approximately 60 lb-ft (81 N•m)).

NOTE: The cover threads are dry-lubricated to permit easy removal.

Loosen the cross recessed pan head screw (shown above) until it is snug against the rim of the cover (27 lb-in (3 N•m)).



TERMINAL COVER

Access to the actuator's terminals requires removal of a threaded cover. For all subsequent configuration and calibration instructions, remove the terminal cover by first locating the (2) cross recessed pan head screws (see below). These screws are designed to help hold the cover in place. Tighten each screw until it is flush with its base and no longer touching the rim of the cover (5 lb-in (.5 N•m)).



Next, unscrew the terminal cover from the actuator body. To loosen, place the shaft of a large screwdriver or rod in one of the channels on the cover and twist counterclockwise. Replace the cover in the same way by hand-tightening using the shaft of the screwdriver until the rim is flush with the body (approximately 50 lb-ft (68 N•m)).

NOTE: The cover threads are dry-lubricated to permit easy removal.

Loosen the (2) cross recessed pan head screws (shown above) until they are snug against the rim of the cover (27 lb-in (3 N•m)).

CONFIGURATION/CALIBRATION

SWITCH CALIBRATION

NOTE: Your Beck actuator was shipped from the factory ready for installation; no electrical adjustments are required before placing it in operation. Each actuator is set up and calibrated to the specifications that were written into the equipment order.

Under normal operating conditions there is no need to recalibrate the actuator. However, if the application requirements change—or are different than specified on the equipment order—the actuator should be recalibrated according to the following procedures.

LIMIT SWITCHES

Actuators are shipped with over-travel limit switches factory-set for 91° of travel unless otherwise specified at time of order. Limit switches must be set inside the range of the built-in, non-adjustable mechanical stops to prevent the possibility of stalling when operating the actuator with the Handswitch. Limit switches can be reset to limit over-travel of the output shaft when the actuator position calibration has been reduced. See the calibration procedure later in this manual. Auxiliary switches are set as shown on the Standard Over-travel Limit and Auxiliary Switch Settings diagram (next page) unless otherwise specified at time of order.

NOTE: To adjust the over-travel limit switches, it is necessary to remove the threaded top cover.

Switches are operated by cams which are clamped onto the shaft. Setting a switch involves positioning the cam so that it operates the switch at the desired point of actuator travel. In the following procedure, the use of a continuity meter is recommended to determine when the switch opens or closes. If such a meter is not available, it is possible to hear the switch click as the contacts open and close.



CAUTION

Do not attach the meter or attempt to move the switch cams until the actuator is disconnected from the line voltage and auxiliary switches are disconnected from external power sources.

SETTING OVER-TRAVEL LIMIT SWITCHES CW AND CCW

This procedure should be used if the factory over-travel limit switch settings are changed in the field. It is advisable to operate the actuator fully in each direction, using the electric Handswitch to check switch settings before attempting to change them. Follow these instructions if they require adjustment:

1. Move the output shaft to the desired CW limit.
2. Turn the Handswitch to the “STOP” position.
3. **Disconnect power from the actuator.**
4. Connect a continuity meter across terminals 2 (DC (+) or AC neutral) and 17 (pulsed AC CW).
5. Insert a small screwdriver into one of the slots on the CW cam (closest to the actuator body). Carefully rotate the cam until the meter shows no continuity (switch contacts open, switch clicks).
6. Disconnect the meter and ensure the Handswitch is in the “STOP” position.
7. Reconnect actuator power.
8. Rotate the actuator’s output shaft in the CCW direction away from the CW travel limit. Note the direction of rotation on the lobe of the cam. The correct cam lobe motion is away from the switch lever with the switch lever on the lower part of the cam. If not correct, return to step 1 and adjust the cam position such that the opposite end of the lobe presses against the switch lever at the desired “trigger” position of the output shaft.
9. Rotate the output shaft again to the desired CW travel limit. If the stopping point is reached, the switch is properly set.
11. Repeat instructions 1–9 for setting the CCW travel limit switch (noting that referenced directions of rotation should be opposite of those used for CW switch setting). Connect continuity meter across terminals 2 (DC (+) or AC neutral) and 17 (pulsed AC CCW).
12. Rotate the index pointer on the output shaft to correspond with the new output shaft position range.

SETTING AUXILIARY LIMIT SWITCHES

Standard switch settings for actuators with 2 (standard) or 4 (optional) auxiliary switches are shown on the following diagram “Standard Over-travel Limit and Auxiliary Switch Settings”. The heavy line indicates a closed circuit. Follow these instructions to change the operating point of auxiliary switches:

1. Move the output shaft to the desired switch trip position.
2. Turn the Handswitch to the “STOP” position.
3. **Disconnect power from the actuator and switch terminals.**
4. Connect the continuity meter across the appropriate terminals. See the actuator wiring diagram under the cover (or the diagram at right).
5. Insert a small screwdriver into one of the slots on the appropriate cam. Carefully rotate the cam until the cam operates the switch.
6. Disconnect the meter and reconnect power.
7. Move the actuator’s output shaft in the desired direction to verify that the cam lobe moves away from the switch lever. If not correct, return to step 1 and adjust the cam position such that the opposite end of the lobe presses against the switch lever at the desired “trigger” position of the output shaft.

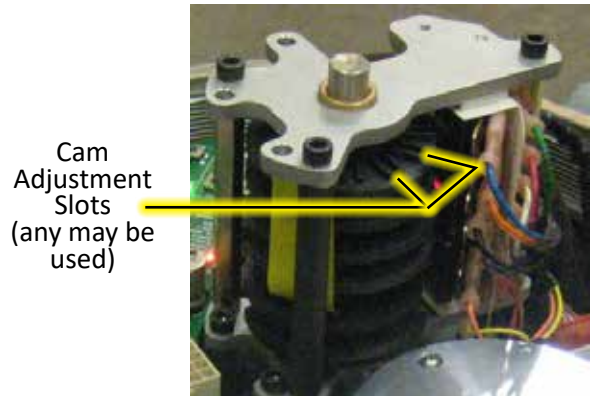

SWITCH CAM ADJUSTMENT

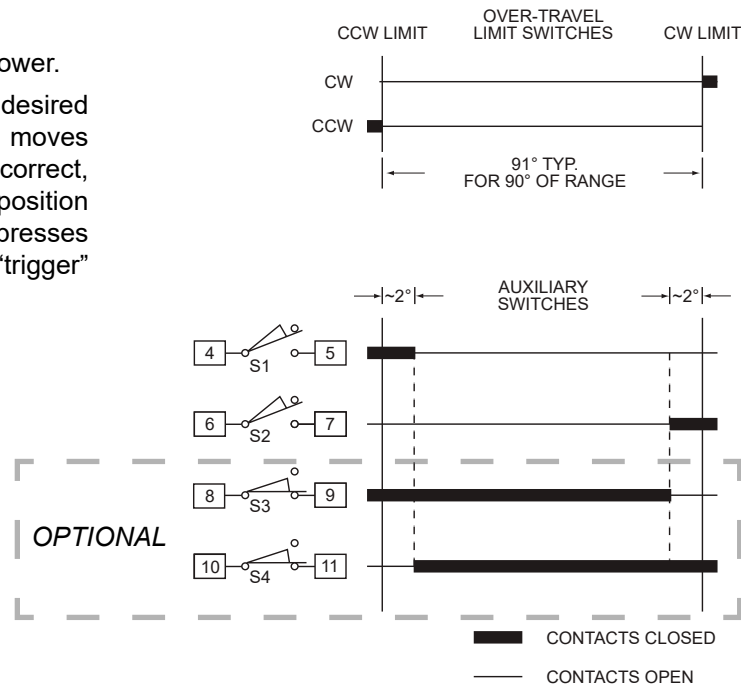

OVER-TRAVEL LIMIT AND AUXILIARY SWITCH SETTINGS

CONFIGURATION/CALIBRATION

CONFIGURING PROGRAMMABLE OUTPUT RELAYS

There are three configurable solid state relays in the Group 57 (see relays 1–3 on the wiring diagram on page 13). All three relays can be configured as alarm relays. Alarm Relay Mode configures the selected relay to activate when a configured alarm condition(s) occurs. The relay polarity (action on alarm) is also programmable.

The three status output relays also have an additional capability: Soft Auxiliary Switch Mode. Soft Auxiliary Switch Mode configures the selected relay to turn on when the actuator output shaft position is outside of the specified percent of full travel.

The following table summarizes the Group 57 relay capabilities:

TERMINAL CONNECTION	RELAY NAME	RELAY CAPABILITIES
Terminals 20 & 21	Relay 1	Single mode alarm relay with programmable activation alarm selection and relay polarity. Configurable via HART, Modbus or with the Serial commands “alarmout”, “alarmoutmask” or “relayconfig 1”.
Terminals 22 & 23	Relay 2	Dual mode Relay. Configurable as a Soft Auxiliary Switch or as an alarm relay with programmable polarity. Configured using the “relayconfig 2” Serial command.
Terminals 25 & 26	Relay 3	Dual mode Relay. Configurable as a Soft Auxiliary Switch or as an alarm relay with programmable polarity. Configured using the “relayconfig 3” Serial command.

ALARM MASK AND POLARITY SETUP

The alarm polarity controls the behavior of the activated relay. The activated relay polarity can be set to:

- “0” setting will open the relay contact when any programmed alarm conditions are active (NC).
- “1” setting will close the relay contact when any programmed alarm conditions are active (NO).

The alarm mask is a bit array that selects which alarm sources will activate the relay. A mask value of zero means that the specific alarm source is ignored. A mask value of one means that the relay will activate if the associated alarm is active.

The alarm mask for each relay is set using the Serial commands listed in the table above. See the “General Configuration Commands” table on page 66 for details.

The alarm mask selection values are shown on page 25.

CONFIGURATION/CALIBRATION

CONFIGURABLE RELAY SETUP

Only the relays at terminals 22/23 and 25/26 are programmable as soft actuator position relays. The "relayconfig" Serial command is used to program this function. Selection of relays with the relayconfig Serial command is as follows:

Number	Terminals	Wiring Diagram Description
relayconfig 1	Terminals 22 and 23	Relay 2
relayconfig 2	Terminals 25 and 26	Relay 3

Details of the "relayconfig" Serial command are listed in the "General Configuration Commands" table on page 66. Shown below are some examples on the use of this command and the resultant relay configuration:

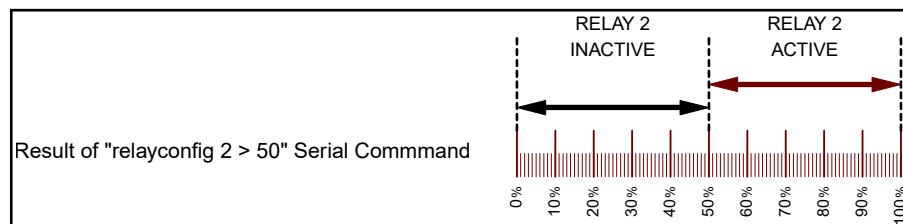
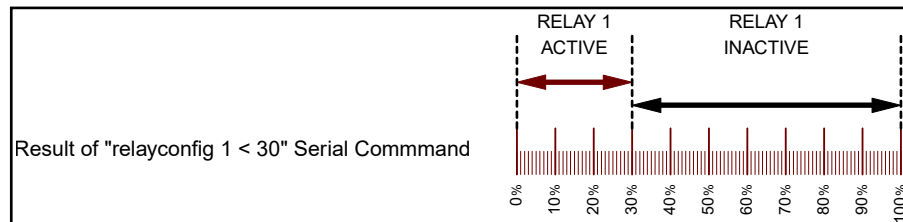
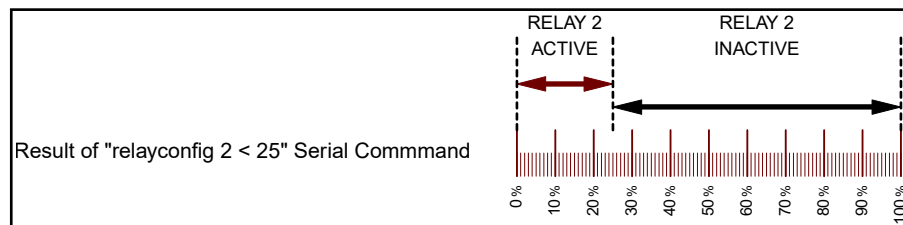
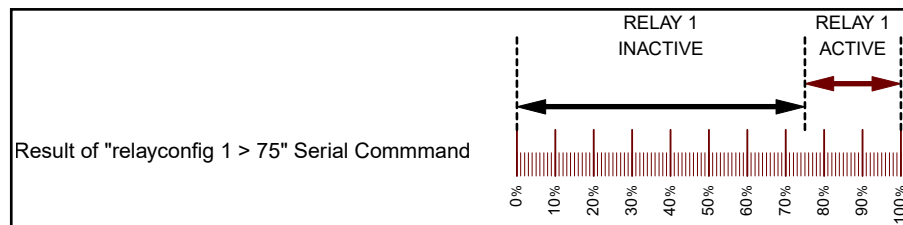

Unlike the physical auxiliary switches, the soft configurable relay function depends on the actuator being powered and a properly functioning position sensor. When the position sensor is in a fault condition, the soft auxiliary relays will be inactive. If the position is not calibrated properly, the relay trip point may not correspond to the expected output shaft position as measured in degrees rotation.

DIRECTION OF OUTPUT SHAFT ROTATION

Rotation direction refers to the direction the output shaft of the actuator rotates in response to an increasing Demand input signal. The rotation is either clockwise (CW) or counterclockwise (CCW) as shown in the figure below. The rotation of the driven load (e.g., damper lever arm) determines the actuator rotation suitable for an application.

Unless otherwise specified at the time of order, the output shaft is factory set to rotate clockwise in response to an increasing Demand signal. The direction of rotation can be changed using one of the following three methods.



Pushbutton method

1. Press and hold the “CALIBRATE” pushbutton, then press the “DIR SEL” pushbutton until the (opposite) direction LED (“DIR_A” or “DIR_B”) is lit.

—OR—

1. Position the actuator at the current 0% position.
2. Press and hold the “CALIBRATE” pushbutton, then press the “SET POSITION 100%” pushbutton until the “ACKN” LED is lit.*

—OR—

1. Position the actuator at the current 100% position.
2. Press and hold the “CALIBRATE” pushbutton, then press the “SET POSITION 0%” pushbutton until the “ACKN” LED is lit.*

—AND—

Ensure the actuator operates as desired.

* If the “ACKN” LED does not light, but the “POS” LED does light, the change was not accepted by the DCM.

NOTE: When any of the above procedures is performed, both the 0% and 100% positions are automatically set.

HART method

Command: Drive Dir

DD Menu Location: MENU 4B

Functions>Configuration>General Setup

Selections:

CW Incr - select if the desired output shaft rotation is clockwise on an increasing Demand signal.

CCW Incr - select if the desired output shaft rotation is counter-clockwise on an increasing Demand signal.

Serial command method

Command: drvdir *n*

Arguments: *n*

0: CW - select if the desired output shaft rotation is clockwise on an increasing Demand signal.

1: CCW - select if the desired output shaft rotation is counter-clockwise on an increasing Demand signal.

Modbus method

Modbus Holding Register 40013, the actuator direction configuration parameter. (See Modbus Holding Register Parameter Map).

STEP SIZE

Step size represents the minimum amount that the Demand signal must change to initiate a change in actuator position.

When the actuator is in AUTO mode, the DCM runs the motor until the output shaft position matches the percentage of Demand signal. When they match, power is removed from the motor. The Demand signal must change by the step size before power is returned to the motor.

The step size is factory set to 0.1°, unless otherwise specified at the time of order. The step size is adjustable from 0.1° to 2.5°. Adjustment is typically not required. The minimum step size regardless of travel is 0.1°.

It may be advantageous in certain applications, where noise or other problems exist, to increase the step size slightly to prevent excessive modulation.

The step size can be changed using the following methods.

NOTE: Changing this parameter online could cause the actuator to reposition.

CONFIGURATION/CALIBRATION

STEP SIZE, con't.

HART method

Command: StepSize

DD Menu Location: MENU 4B

Functions>Configuration>General Setup>

Enter the desired step size between "0.10" and "2.50".

Serial command method

Command: stepsize #.##

Arguments: #.## Desired step size (in degrees) of one incremental movement of output shaft travel. Acceptable range is between "0.10" and "2.50".

Modbus method

Modbus Holding Registers 40021 and 40022, the stepsize floating point register set. (See Modbus Holding Register Parameter Map and the Floating Point Byte Order sections).

RESTORE FACTORY SETTINGS

All DCM's are shipped from the factory configured per the customer instructions at the time of order. A complete copy of the factory configuration is stored on the DCM. You can revert to the factory settings at any time using one of the following methods.

NOTE: When the factory settings are restored, the Operation Mode (HART DD menu location 3E or Serial command "opmode") will not be changed for safety reasons. The operation mode should be set to "Follow" for normal automatic operation.

Pushbutton method

The factory pushbutton is used in combination with the other buttons to restore a limited selection of factory settings related to the button selected. The following chart describes the settings that will be restored:

Pushbutton Combination	HART/Analog Mode Action	MODBUS Mode Action
FACTORY + DEM 0%	Restore the Demand 0% milliAmp value to the factory set calibration.	Restore standard Modbus communications defaults to baudrate, parity and polling address. The standard defaults are 19200-8-E-1 with a polling address of 246.

Pushbutton Combination	HART/Analog Mode Action	MODBUS Mode Action
FACTORY + DEM 100%	Restore the Demand 100% milliAmp value to the factory set calibration.	Restore factory Modbus communications defaults to baudrate, parity and polling address. These defaults are the settings programmed into the actuator when it was ordered.
FACTORY + POS 0%	Restore the actuator output position for 0% end of travel to the factory set calibration.	Same as HART/Analog.
FACTORY + POS 100%	Restore the actuator output position for 100% end of travel to the factory set calibration.	Same as HART/Analog.
FACTORY + DIR SEL	Restore the actuator output shaft rotation direction to the factory set calibration.	Same as HART/Analog.

HART method

Command: Restore to Factory

Running this function will restore all configurable parameters to the original factory settings.

DD Menu Location: MENU 3C

Functions> Configuration

Serial command method

Command: restoremodes *n*

Arguments: *n*

1: Used as a safety measure, the number one must be entered as an argument to prevent someone from running the restoremodes command errantly.

TRAVEL (DEGREES ROTATION)

Travel is defined as the number of degrees of rotation by the output shaft between the 0% and 100% positions. Unless otherwise specified, all models are factory configured for 90 degrees rotation, which is the maximum for 57-109 models. 57-209 models may be configured for a maximum of 100 degrees of travel.

Some exceptional applications may require less actuator travel. Travel calibration can be performed to reduce actuator travel. Travel less than 60 degrees is not recommended.

The output shaft is limited to 98° of rotation by mechanical stops for 57-109 models..

It is possible to change the full travel of the actuator output shaft, if necessary. To change the Beck output shaft full range of rotation, electronic calibration changes can be made by using one of the two procedures below. These procedures can be performed by using the methods that follow.

- 1. 0% and 100% Position Calibration:** Physically drive the actuator to the new 0% and 100% positions. Use the Pushbutton or HART method to set the new end points.
- 2. Changing Travel in Degrees:** This allows the calibration to be changed without moving the actuator output shaft. Use the HART or Serial command method to set the desired full travel rotation in degrees. The 0% position will remain the same, but the 100% position will change to accommodate the new travel setting.

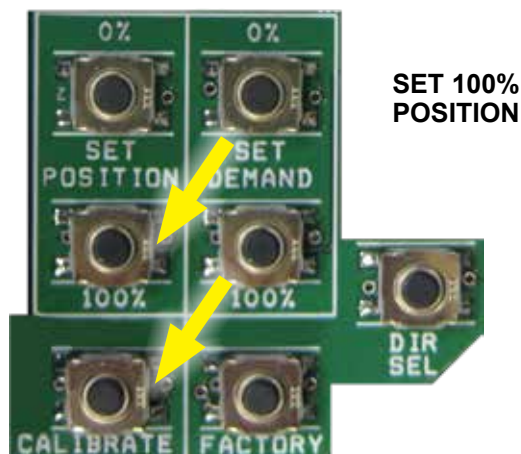
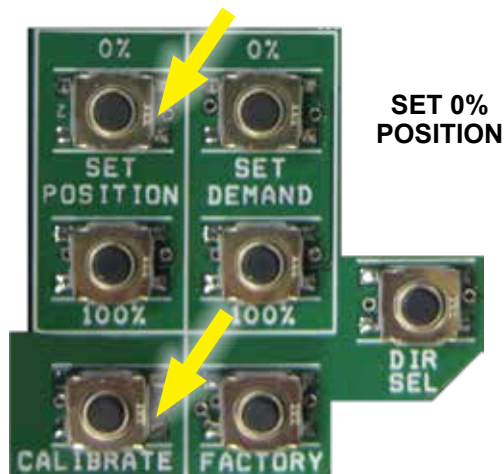

NOTE: In addition to recalibrating the electronics, the CW / CCW over-travel switches should also be adjusted to open just beyond the new electronic limits; this ensures that manual operation with the Handswitch will not cause over-travel or create a stall condition.

Calibrate the 0% and 100% positions:

Pushbutton method

1. Move the output shaft to the desired 0% position.
2. Press and hold the "CALIBRATE" pushbutton then press the "SET POSITION 0%" pushbutton until the "ACKN" LED is lit.
3. Move the output shaft to the desired 100% position.
4. Press and hold the "CALIBRATE" pushbutton then press the "SET POSITION 100%" pushbutton until the "ACKN" LED is lit.
5. Adjust over-travel limit switches as necessary to accommodate the new rotation.

HART method

Command: Set Pos 0%

Select when the output shaft is at the desired 0% position.

Command: Set Pos 100%

Select when the output shaft is at the desired 100% position.

DD Menu Location: MENU 4C

Functions>Configuration>PositionSensrSetup>

Change Travel Degrees:

HART method

Command: Travel

Enter the desired full stroke rotation in degrees.

HART DD Menu Location: MENU 4B

Functions>Configuration>General Setup>

Serial command method

Command: travel ###

Arguments: ### The desired full-stroke rotation in degrees.

Modbus method

Modbus Holding Registers 40052 and 40053, the travelspan value floating point register set. (See Modbus Holding Register Parameter Map and the Floating Point Byte Order sections).

CONFIGURATION/CALIBRATION

DEMAND CALIBRATION

DCM boards are designed to accept a 4–20 mA Demand signal. The input comes calibrated from the factory for the full range unless otherwise specified by the customer. It is not necessary to calibrate the Demand input when the actuator is installed; however, if the Demand needs to be calibrated to accommodate unusual operating conditions, two guidelines must be followed: First, the value for 0% must be greater than 0.5 mA and the value for 100% must be less than 21 mA. Second, the difference between 0% and 100% (minimum span) must be at least 4 mA. Use any of the following methods to calibrate Demand. Actuators may also be configured for split-range operation—contact the factory for details.

Calibrate the 0% and 100% Demand signal:

Pushbutton method

1. Ensure the Handswitch is in the “STOP” position. This will prevent the actuator from repositioning during this procedure.
2. Apply the desired 0% Demand input signal to the actuator (e.g., 4 mA for 4–20 mA signal).
3. Press and hold the “CALIBRATE” pushbutton, then press the “SET DEMAND 0%” pushbutton until the “ACKN” LED is lit.*
4. Apply the desired 100% Demand input signal to the actuator (e.g., 20 mA for 4–20 mA signal).
5. Press and hold the “CALIBRATE” pushbutton, then press the “SET DEMAND 100%” pushbutton until the “ACKN” LED is lit.*
6. Turn the Handswitch to the “AUTO” position. NOTE: The actuator may reposition.
7. Run the actuator through its full operational range to ensure proper response to the Demand input signal.

*If the “ACKN” LED does not light, but the “DEM” LED does light, the calibration is out of acceptable range and was not accepted by the DCM. This is typically caused by trying to set 0% and 100% values too close together (i.e., less than 4 mA difference).

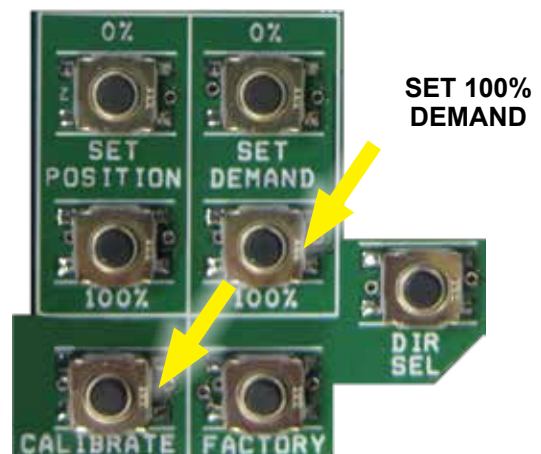
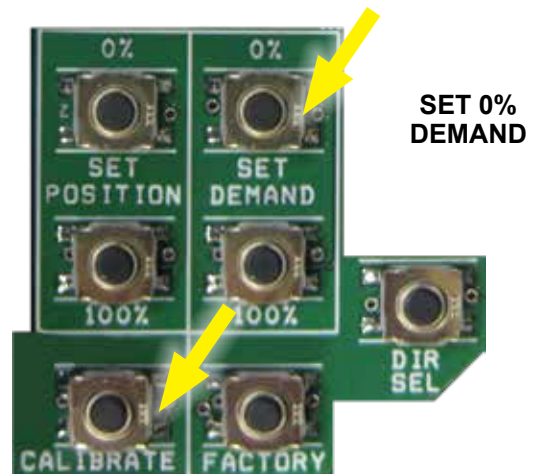

HART method

Command: DemRngLwr

Enter the desired 0% Demand signal ("4.00" to "16.00" mA).

Command: DemRngUpR

Enter the desired 100% Demand signal ("8.00" to "20.00" mA).

DD Menu Location: MENU 4D

Functions>Configuration>Demand Setup>

Serial command method

Command: dem0pctma #.##

Arguments: #.## Desired 0% Demand signal ("4.00" to "16.00" mA).

Command: dem100pctma #.##

Arguments: #.## Desired 100% Demand signal ("8.00" to "20.00" mA).

LOSS OF DEMAND SIGNAL (LOS)

The DCM is capable of determining if the Demand input signal to the actuator is outside of an acceptable range. The DCM uses a configurable loss of signal (LOS) threshold to determine if the Demand signal falls below a minimum value. Unless otherwise specified in the original order, the factory-set threshold is 3.2 mA. When the DCM senses an LOS condition, an alarm condition will result, illuminating the "Demand" status indication LED. The actuator then responds according to the LOS setting. The DCM can be configured for one of two LOS actions:

1. **Stay in Place**—the actuator output shaft stays in place until the Demand signal returns to the acceptable range. This is the factory default.
2. **Go-to-Position**—the actuator output shaft will move to a preset position, designated in percentage of travel. For example, if the LOS action is set for 50%, the actuator output shaft will drive to the 12 mA position (based on a 4-20 mA span).

The LOS parameters can be configured using HART or Serial commands.



CAUTION

The following procedures could cause the actuator to reposition, which can adversely affect the process and cause potentially dangerous conditions.

Configure the LOS threshold:

HART method

Command: DemLimLwr
Enter "0.00" to "12.00" mA. Decimal value of the lower threshold for detecting LOS. (e.g., the typical value for a 4–20 mA system is "3.20").

DD Menu Location: MENU 4D
Functions>Configuration>Demand Setup>

Serial command method

Command: demlos ###

Arguments: ### Enter the desired Demand signal in mA below which LOS occurs (e.g., the typical value for a 4–20 mA system is "3.20").

Configure the LOS mode:

HART method

Command: LOS Mode

DD Menu Location: MENU 4D
Functions>Configuration>Demand Setup>

Selections:

Stay - select if the actuator should hold output shaft position when a loss of signal occurs.

Go-to-Pos - select if the output shaft should go to a specific position when a loss of signal condition occurs. Configure the position with LOS Pos.

Serial command method

Command: demlos *n*

Arguments: *n* Enter the desired mode

sip: (actuator will stay in place).

gtp: (actuator will go to position set in "demlogtp" command)

pat: (same as "sip", but suppresses the alarm).

Configure the LOS position when Go-to-Pos is selected:

HART method

Command: LOS Pos
Enter "-5.00%" to "105.00%". The percentage of full travel the actuator will move upon LOS.

DD Menu Location: MENU 4D
Functions>Configuration>Demand Setup>

Serial command method

Command: demlogtp ##.##

Arguments: ##.## Desired position of actuator if "gtp" is selected in "demlos". Position is expressed as a percentage of actuator travel in decimal form (e.g., 50% = "50.00").

CONFIGURATION/CALIBRATION

DEMAND CHARACTERIZATION CURVES

The DCM can be configured to interpret the applied Demand signal for linear or non-linear output shaft position response. Three predefined Demand signal response curves are available for use including: Linear, Square, and Square Root. A chart of each of these predefined responses is provided for your reference.

In addition to the three predefined characterizer curves, the DCM also allows a custom user-defined curve to be configured. This option is called "Dem Curve Spcl".

The Demand characterization curve type can be configured with the following methods:

Change the Demand characterization curve:

HART method

Command: Dem Curve

DD Menu Location: MENU 4D

Functions>Configuration>Demand Setup

Selections:

Linear - select if the actual position % should match the applied Demand %.

Square Root - select if the actual position % should match the square root of the applied Demand %.*

Dem Curve Spcl - select if a user-defined response is desired (see characterization on the following page to define the desired response curve).

Square - select if the actual position % should match the square of the applied Demand %.

Serial command method

Command: demfunc *n*

Arguments: *n* Enter the integer that represents the desired Demand signal response as follows:

0: Linear - select if the actual position % should match the applied Demand %.

1: Square Root - select if the actual position % should match the square root of the applied Demand %.

4: Special Curve - select if a user-defined response is desired (see characterization on the following page to set the desired response curve).

5: Square - select if the actual position % should match the square of the applied Demand % (e.g., "demfunc 0" sets the actuator to a linear Demand response).

DEMAND SIGNAL RESPONSE CURVES

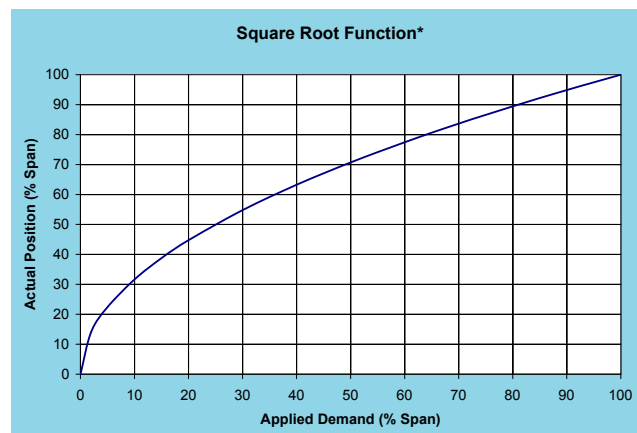
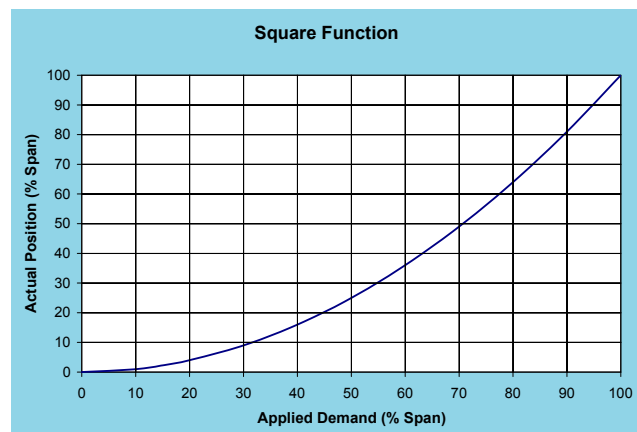
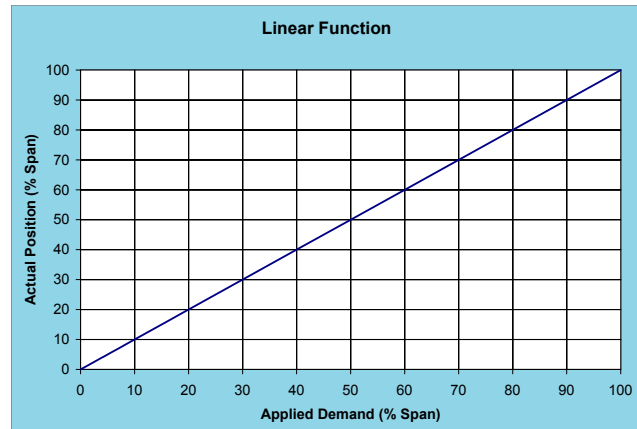

***NOTE**

Implementing a square root characterization creates extremely high gain when the Demand signal is below 10%; this causes instability and is unsuitable for control at this level. Do not apply this curve if the control loop may need to modulate at the lower range of travel.

USER-DEFINED CHARACTERIZATION

Special curves may be created from up to 20 segments, each of which has a node for a starting point and a node for an ending point. All 20 segments do not have to be used, but the used segments must be grouped together starting with segment 1. Segments cannot be skipped.

A node is a coordinate comprised of an X,Y point. When defining nodes, X-values and Y-values must increase as the node number increases. For example, the X-value and Y-value of node 2 must be higher than the X-value and Y-value of node 1. Nodes cannot be skipped. Always start at node 1.

Unless otherwise specified, the Special curve ships from the factory defined as a linear function (i.e., one segment beginning with node 1 at X = 0%, Y = 0% and ending with node 2 at X = 100%, Y = 100%). X-values are typically chosen to give a reasonable spacing in Y-values.

The customer may specify a custom characterization by entering X- and Y-value pairs to define line segments between 0% and 100%.

For example, the table at right uses 5 segments to approximate the square function curve (i.e., $y=x^2$). Segments 1 through 5 are needed, so nodes 1 through 6 are used.

The following methods can be used to configure a user-defined characterization curve:

Change the user-defined characterization:

HART method

Command: DemNode1X

Enter desired X-value as a percentage for node 1

Command: DemNode1Y

Enter desired Y-value as a percentage for node 1

Repeat above procedures for each node required.

DD Menu Location: MENU 5A

Functions>Configuration>Demand Setup>Dem Curve Spcl

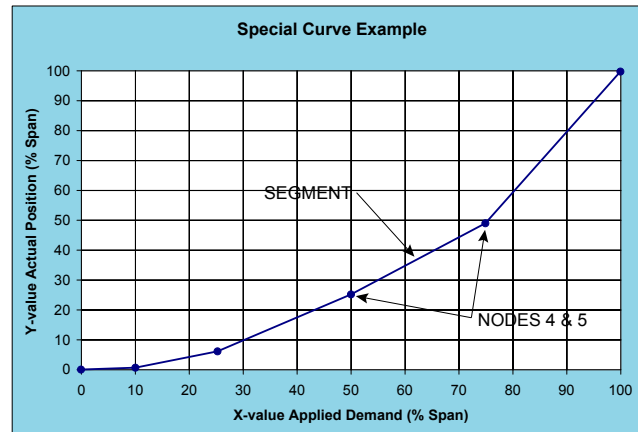

NODE	X-VALUE (DEMAND) % SPAN	Y-VALUE (POSITION) % SPAN
1	0%	0%
2	10%	1%
3	25%	6%
4	50%	25%
5	75%	49%
6	100%	100%

Serial command method

Change the user-defined characterization:

Command: charset *n1*, *n2*, *n3*

Arguments: *n1*, *n2*, *n3*

Where:

n1 = node number.

n2 = X-value as a percentage.

n3 = Y-value as a percentage.

Values must be separated by commas as shown.

Repeat procedure for each node required.

View the user-defined characterization:

Command: charlist ###

Arguments: ### Enter node number between 1 and 21 or "all".

Displays defined nodes.

Clear the user-defined characterization:

Command: charclear ###

Arguments: ### Enter node number between 1 and 21.

Clears a defined node by setting it to unused.

Will also clear any node numerically higher.

CONFIGURATION/CALIBRATION

POSITION FEEDBACK SIGNAL

DCM control electronics provide a 4–20 mA analog output signal that represents the actuator output shaft position. The DCM monitors an internal position voltage from the position sensor, controls the actuator position, and sources a 4–20 mA signal to terminals 37 (–) and 38 (+). The Feedback will correspond with the 0% and 100% output shaft positions, as determined by the position calibration. **There is no need for separate Feedback calibration.**

The user has the option of enabling or disabling the position Feedback signal. The factory default configuration will have the Feedback enabled. When the Feedback is enabled, but not in use (i.e., not wired to a load) the "STAT" and "FB_OPEN" LEDs will illuminate. This status alarm is helpful in alerting the user to open Feedback wiring, but can be a nuisance when the Feedback is purposely disconnected or unused. Disabling the Feedback signal turns off the output and eliminates the status alarm. If HART or Serial communications are not immediately available to disable the Feedback signal, you can apply a 250 ohm load resistor across the Feedback terminals 37 (–) and 38 (+) to simulate a Feedback loop and eliminate the alarm.

If desired, the milliamp position Feedback values for 0% and 100% positions can be configured differently than the respective standard factory calibration of 4 mA and 20 mA. A valid 0% position Feedback signal value can be configured anywhere in a 3–16 mA range, while a 100% signal value can be configured from 7–21 mA. The 100% milliamp value must exceed the 0% value by at least 4 mA.

The factory calibrated relationship between the position Feedback signal and the output shaft position is linear (i.e., 0% to 100% Feedback signal corresponds directly with 0% to 100% shaft position). This relationship is suitable for most applications; however, the Feedback to Demand relationship can be changed to compensate for characterized Demand signals. This relationship is called "Inverse Demand". Configuring this option allows the position Demand feedback signal to match the uncharacterized Demand signal rather than true output shaft position.

The following example assumes 4–20 mA Demand and position signals. If the Demand is set to a square characterization, then a 12 mA Demand corresponds to 25% position. If the position Feedback curve is set to linear, then Feedback at 25% is 8 mA. For some control systems, having the Demand at 12 mA and the Feedback at 8 mA may cause a deviation alarm. The Feedback curve can be set to "Inverse Demand" so the Demand and Feedback match when the actuator is balanced. In this example, with Feedback set to "Inverse Demand" and the output shaft position at 25%, the Feedback signal would be 12 mA.

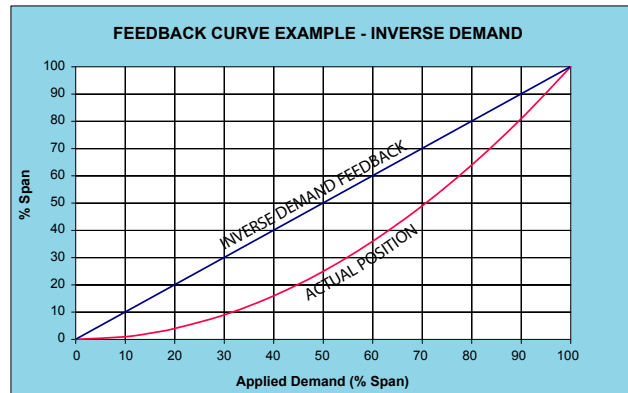
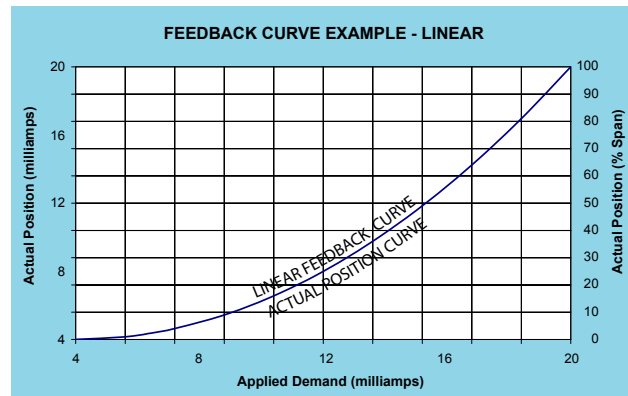

The following methods describe how to enable or disable position Feedback, set the 0% and 100% milliamp values and select the desired Feedback response:

Enable/disable the position feedback:**HART** method**Command:** Feedback**DD Menu Location: MENU 4E**

Functions>Configuration>Feedback Setup>

Selections:**Enabled** - to enable position Feedback.**Disabled** - to disable position Feedback.**Serial** command method**Command:** iomode *n***Arguments:** *n***0:** Feedback disabled.**1:** Feedback enabled.**Modbus** method

Modbus Holding Register 40029, the io_select register. Set to zero to disable analog feedback and one to enable it (See Modbus Holding Register Parameter Map).

Set the feedback range lower and upper values:**HART** method**Command:** FB RngLwr

Enter the milliamp value that corresponds with 0% position. Acceptable range "3.00"–"16.00" (typically, "4.00").

Command: FB RngUp

Enter the milliamp value that corresponds with 100% position. Acceptable range "7.00"–"21.00" (typically, "20.00").

DD Menu Location: MENU 4E

Functions>Configuration>Feedback Setup>

Serial command method**Command:** fdbk0pctma #.##

Arguments: #.## Desired Feedback signal in mA at 0% output shaft position. Minimum value is "3.00".

Command: fdbk100pctma #.##

Arguments: #.## Desired Feedback signal in mA at 100% output shaft position. Maximum value is "21.00".

Modbus method

Feedback lower range is set using Modbus floating point formatted Holding Registers 40030 and 40031. Feedback upper range is set using Modbus floating point formatted Holding Registers 40032 and 40033 (See Modbus Holding Register Parameter Map and the Floating Point Byte Order sections).

Set the feedback characterization curve:**HART** method**Command:** FB Curve**DD Menu Location: MENU 4E**

Functions>Configuration>Feedback Setup>

Selections:**Linear** - to enable a linear feedback signal**InvDem** - to enable an inverted Demand feedback signal.**Serial** command method**Command:** fdbkfunc *n***Arguments:** *n***0:** Linear Feedback signal.**1:** Inverse Demand Feedback signal.

CONFIGURATION/CALIBRATION

TORQUE SENSING (Optional)

Torque sensing is an optional feature that measures the output torque of the actuator as a percentage of its rated torque capability. It provides a number of configurable features including live torque measurement, historical peak torque data, overtorque alarm and overtorque protection. Torque sensing cannot be retrofitted into existing actuators.

Actuators equipped with optional torque sensing are calibrated at the factory. There should never be a need to calibrate the torque measurement; however, if the DCM is ever replaced, the torque sensing calibration constants will need to be set. There are two calibration constants consisting of a torque signal null (zero) and a torque signal span. These calibration constants are unique to the actuator and are recorded at the factory against the actuator Serial number. If the constants are needed to restore calibration, contact the factory by phone or email with the actuator Serial number to obtain the values. As a backup, torque calibration constants are also printed on a label inside the actuator, under the top cover.

Although actuators so equipped are shipped from the factory with torque sensing enabled, the overtorque protection feature is disabled. Torque sensing and overtorque protection can be either enabled or disabled, as desired. In addition, the torque alarm threshold value can be changed, as can the overtorque protection threshold.

The following methods allow the user to enable/disable torque sensing, set the torque null, and set the torque constant. Methods for using and configuring the other torque features also follow:

Enable / disable torque sensing:

HART method

Command: Trq/Thrust

DD Menu Location: MENU 4F

Functions>Configuration>Torque Setup>

Selections:

Enabled - to enable torque sensing.

Disabled - to disable torque sensing.

Serial command method

Command: torqenable *n*

Arguments: *n*

0: disables torque sensing and torque alarm.

1: enables torque sensing and torque alarm.

Modbus method

Modbus Holding Register 40035, the trq_thrust_sensor_installed configuration parameter should be set to 2. Modbus Holding Register 40036, the trq thrust sensor enabled parameter, is set to zero to disable torque sensing and one to enable torque sensing. (See Modbus Holding Register Parameter Map).

Set the torque null and constant values:

HART method

Command: Trq Null

Number representing 0% torque. Enter the torque null value that is affixed to the actuator body inside the terminal compartment.

Command: Trq Const

Number representing the torque span value. Enter the torque constant value that is affixed to the actuator body inside the terminal compartment.

DD Menu Location: MENU 4F

Functions>Configuration>Torque Setup>

Serial command method

Command: torq0k ###

Arguments: ### Number representing 0% torque. Enter the torque null value that is affixed to the actuator body inside the terminal compartment.

Command: torqconst ###

Arguments: ### Number representing the torque span value. Enter the torque constant value that is affixed to the actuator body inside the terminal compartment.

Modbus method

Modbus Holding Registers 40039 and 40040, the trq thrust null floating point register set, are used to set the null. Modbus Holding Registers 40037 and 40039, the trq thrust span floating point register set, are used to set the span. (See Modbus Holding Register Parameter Map and the Floating Point Byte Order sections).

LIVE / HISTORICAL TORQUE (Requires Optional Torque Sensing)

The live torque measurement can be accessed through the HART or Serial port interface. Historical peak measurements are recorded for 10 equal segments of travel in both the CW and CCW travel directions. Historic data is also available through the HART or Serial port interface.

View the live torque measurement:**HART** method**Command:** Trq/Thrust

Displays the present torque reading as a percentage of the actuator's rated torque.

DD Menu Location: MENU 1**Serial** command method**Command:** torq

Displays the torque on the output shaft measurement as a percentage of actuator rating.

Arguments: No argument required.**Modbus** method

Live torque value is available in scaled integer and floating point formats. See the section "Process Variable Data Formats" on page 101.

View historical peak torque values:**HART** method**Command:** Segment 1 through 10

Displays the historical peak torque values. Values are displayed for every 10% segment of full actuator travel and also for both the CW and CCW directions of travel.

DD Menu Location: MENU 4J

Functions>Diagnostics>CW Torque

DD Menu Location: MENU 4K

Functions>Diagnostics>CCW Torque

Serial command method**Command:** torqprof

Displays a three table column:

1. Travel divided into 10 segments
2. peak torque measured in each segment with motor running CW
3. peak torque measured in each segment with motor running CCW

Arguments: No argument required.

OVERTORQUE PROTECTION (Requires Optional Torque Sensing)

Overtorque protection protects both the actuator and driven equipment from damage when the torque exceeds the set threshold (configurable). Actuators normally ship from the factory with this feature disabled, but it can be enabled in the field using either HART or the Serial interface. The factory configured threshold

is 115% of rated actuator torque, and can be configured as low as 25%.

The following methods show how to enable/disable the overtorque protection and how to set the threshold.

Enable / disable overtorque protection:**HART** method**Command:** Ovt Prot**DD Menu Location:** MENU 4F

Functions>Configuration>Torque Setup>

Selections:**Enabled** - to enable overtorque protection.**Disabled** - to disable overtorque protection.**Serial** command method**Command:** ovtstop *n***Arguments:** *n***0:** disables overtorque protection.**1:** enables overtorque protection.**Modbus** method

Modbus Holding Register 40044, the ovtstop parameter is set to zero to disable overtorque protection and one to enable protection. (See Modbus Holding Register Parameter Map).

Set the overtorque protection threshold:**HART** method**Command:** ShutDwnTrq

Enter the overtorque protection threshold as a percentage of rated torque (25%–115%).

DD Menu Location: MENU 4F

Functions>Configuration>Torque Setup>

Serial command method**Command:** ovtstoplevel ###

Arguments: ### the overtorque protection threshold as a percentage of rated torque (25% to 115%).

Modbus method

Modbus Holding Registers 40045 and 40046, the shutdown_trq_thrust_level floating point register set. (See Modbus Holding Register Parameter Map and the Floating Point Byte Order sections).

CONFIGURATION/CALIBRATION

OVERTORQUE ALARM (Requires Optional Torque Sensing)

When the torque reaches an alarm threshold (factory configured for 105% of rated torque), a status alarm will be initiated causing the “STAT” LED to illuminate. Disabling the torque sensor also disables the torque alarm. When the measured torque drops below the threshold the status alarm is automatically reset.

The following method allows the user to set the torque alarm threshold between 61% and 105%.

Set the torque alarm threshold:

HART method

Command: AlarmLevel

Enter the alarm level as a percentage of torque (61%–105%).

DD Menu Location: MENU 4F

Functions>Configuration>Torque Setup>

Serial command method

Command: torqalarm ###

Arguments: ### Alarm level as a percentage of torque (61%–105%).

Modbus method

Modbus Holding Registers 40041 and 40042, the trq_thrust_limit_upper floating point register set. (See Modbus Holding Register Parameter Map and the Floating Point Byte Order sections).

TEMPERATURE SENSING

DCMs are equipped with an internal temperature sensing circuit. The real-time temperature and the historical temperature extremes (low and high) are available.

Temperature units can be selected to show either Fahrenheit or Celsius.

An alarm condition initiates if the actuator’s real-time temperature falls outside the actuator rating (see “General Specifications”, page 4). The “STAT” LED and the “TEMPF” LED will light, and will automatically reset when the temperature is once again within the actuator rating.

View real-time temperature & historical extremes:

HART method

Command: Temp

Displays the real-time temperature as read by the DCM.

DD Menu Location: MENU 1

Command: High Temp

Displays the historical high temperature.

Command: Low Temp

Displays the historical low temperature.

DD Menu Location: MENU 3D

Functions>Statistics

Serial command method

Command: temperature

Arguments:

When entered with no argument, the command returns the real-time temperature as well as the historical high and low temperatures.

Modbus method

Modbus Input Register 30032, the ambient_value_degc parameter contains the signed integer value in Celsius and Modbus Input Register 30033, the ambient_value_degF parameter contains the signed integer value in Fahrenheit (See Modbus Holding Register Parameter Map).

Set temperature units:

HART method

Command: Temperature Unit

DD Menu Location: MENU 4B

Functions>Configuration>General Setup

Selections:

degF - Set the temp. units to degrees Fahrenheit.

degC - Set the temp. units to degrees Celsius.

Serial command method

Command: temperature *n*

Arguments: *n*

F: Set the temp. units to degrees Fahrenheit.

C: Set the temp. units to degrees Celsius.

STALL PROTECTION

The DCM board provides protection for the actuator in the event of a stall. Stall protection is activated when the actuator is unable to achieve the proper position within a defined stall time due to a mechanical impediment or excessive load.

The DCM senses when the motor moves the output shaft in one direction longer than the configured "stall time". The DCM then shuts off power to the motor, preventing further actuator movement. When the stall condition occurs, the "STAT" LED will illuminate.

Resetting due to a stall condition is achieved by reversing the Demand signal, cycling the actuator power, or submitting a reset command via HART or the Serial port.

The stall protection feature can be enabled or disabled and the stall time may be configured between 30 and 475 seconds. This feature is factory enabled and the default setting is 300 seconds. If reconfiguring, it is advisable to configure the stall time with a value greater than the maximum stroke time to avoid false stall protection events and alarms.

Enable / disable stall protection:

HART method

Command: StallProt

DD Menu Location: MENU 4B

Functions>Configuration>General Setup>

Selections:

Enabled - to enable stall protection.

Disabled - to disable stall protection.

Serial command method

Command: stallprot *n*

Arguments: *n*

0: stall protection disabled.

1: stall protection enabled.

Modbus method

Modbus Holding Register 40048, the stall_protection configuration parameter is set to zero to disable and one to enable. (See Modbus Holding Register Parameter Map).

Configure the stall time:

HART method

Command: Stall Time

Enter the stall time in seconds. Valid stall times are 30 to 450 seconds.

DD Menu Location: MENU 4B

Functions>Configuration>General Setup>

Serial command method

Command: stalltime ###

Arguments: ### Enter the stall time in seconds. Valid stall times are "30" to "450".

Modbus method

Modbus Holding Registers 40049 and 40050, the drive_stall_time floating point register set. (See Modbus Holding Register Parameter Map and the Floating Point Byte Order sections).

Reset a stall condition:

HART method

Command: Reset Stall

Select to reset a stall condition.

DD Menu Location: MENU 3E

Functions>Manual Operation>

Serial command method

Command: un stall

Enter to reset a stall condition.

Modbus method

Modbus Holding Register 40025, the utility_command_register will un stall the actuator when a value of **21930** is written to it. During a write operation the actuator will respond with the value written. When read separately, the register will always equal zero (See Modbus Holding Register Parameter Map).

MAINTENANCE

MOTOR ASSEMBLY

The control motor is field replaceable, but not field repairable. **Do not disassemble the motor.** Disassembly of the motor will result in a loss of torque that can only be restored by returning the motor to the factory for re-magnetizing.

Motor assembly replacement instructions follow:



WARNING

Electrical shock hazard. Disconnect power before proceeding.

REMOVE THE MOTOR ASSEMBLY:

Disconnect the motor wire connector on the DCM board (shown below—the larger black connector closest to the motor, labeled “J6”).

Remove the (4) 10-32 x 0.50 socket head cap mounting screws and then carefully lift the motor assembly out of the actuator body.

INSTALL THE NEW MOTOR ASSEMBLY:

Connect the motor wire connector (J6) to the DCM board. Carefully slide the motor into the actuator body. Rotate the motor shaft, if necessary, to engage the pinion with the gearing. Install new motor assembly mounting screws (provided) and torque to 6 lb-ft (8 N•m).



SELF-LOCKING MECHANISM (SLM)

The SLM is assembled to the front of the motor and couples the motor to the gear train. The primary function of the SLM is to lock the gear train in place when the motor is de-energized. When the motor is energized, the SLM releases and allows the motor to drive the gearing.

There is no recommended maintenance interval for the SLM. The SLM can last for many years in normal service. SLM wear is a function of loading and the number of starts/stops the motor experiences over time. Overloading or stalling the actuator will accelerate SLM wear.

Signs of wear include the inability of the actuator to hold position when the motor is de-energized. This could result in persistent on-off oscillation. Severe SLM wear or damage may result in a loss of torque at the output shaft.

Disassembly and close inspection of the SLM components is required to fully evaluate its condition.

LUBRICATION / GEARING

Periodic lubrication is not required.

**WARNING**

Electrical shock hazard. Disconnect power before proceeding.

DISASSEMBLY AND CLEANING

When wear or damage is suspected, disassembly and cleaning may be required to determine the extent of needed repairs. Worn or damaged parts may be replaced by installing a new subassembly (the drive collar, however, is not field replaceable). Refer to the illustration on page 42 for component identification.

For SLM disassembly and inspection:

1. Disconnect power from the actuator.
2. Remove the motor assembly (page 40). Handle the motor with care to avoid damage to the rotor shaft.
3. Remove the two SLM assembly screws (4-40, flat head, cross-recessed).
4. Carefully remove the grease shield.
5. Pushing down firmly on the pinion, measure the gap between the stop collar and the thrust bearing. This gap should measure 0.015 ± 0.005 ". An excessive gap indicates worn SLM components.
6. Use a felt tip pen to mark the location of the stop collar on the shaft. Support the end of the rotor shaft to prevent it from bending, and drive the 1/8" spring pin out. Carefully (the spring assembly is spring-loaded), remove the stop collar, thrust bearing, pinion, spring, steel balls and locking disc. DO NOT remove the drive collar or motor shield.

**CAUTION**

Do not disassemble the motor any further, as it has no other user serviceable parts. Further disassembly will result in demagnetization of the motor and loss of the required torque.

7. Clean grease from the pinion and locking disc for inspection. A small amount of dust residue from the friction liner is normal. Clean the drive collar detents with a rag and inspect for wear. Inspect the friction liner for excessive wear or damage. If the friction liner does not appear to be damaged, clean with alcohol to remove any contaminants.
8. Worn or damaged parts are replaced by installing a new subassembly (provided in the SLM replacement kit, 12-8066-02). Note, wear

on the pinion teeth may indicate wear on the meshing gear. Further inspection of the gearing is recommended. Wear on the meshing gear or drive collar detents will require factory repair.

REBUILD INSTRUCTIONS

If any components need to be replaced, skip to "REPLACEMENT INSTRUCTIONS", page 42).

1. Apply a film of grease (Mobiltemp SHC-32 or equivalent) to the surface of the ball detents (16 places). Apply a *thin* film of grease to the inner diameter of the locking disc bore. Do not let the grease contact any friction surfaces. Excess grease can contaminate the friction surface and reduce SLM effectiveness.
2. With the motor shaft pointed up, place a steel ball into each of the drive collar detents. Install the spur gear and locking disc with friction liner. Place a steel ball into each of the detents on the top of the locking disc.
3. Install the spring and pinion, making sure all steel balls are properly seated in the detents of the drive collar, locking disc, and pinion.
4. Install the thrust bearing, then the stop collar as follows. Align the stop collar with the pen mark made during disassembly, then insert a 1/8" pilot punch through the stop collar hole and into the motor shaft to hold it in place.
5. Pushing down firmly on the pinion, measure the gap between the stop collar and the thrust bearing. This gap should measure $0.015 \pm .005$ ". This space is necessary to ensure proper operation. Add shims, if necessary. Install the 1/8" spring pin while supporting the shaft.
6. Install the grease shield. Rotate the shield to align the holes with the spur gear, then reinstall the (2) SLM assembly screws—torque to 4 lb-in (.5 N•m).
7. Recoat the pinion gear teeth, spur gear teeth and other gearing accessible in the motor cavity with a layer of Mobiltemp SHC-32 or equivalent.
8. Reinstall the motor assembly (see page 40).

Continued

MAINTENANCE

SELF-LOCKING MECHANISM (SLM), con't.

REPLACEMENT INSTRUCTIONS

1. Install a new SLM subassembly provided in SLM Replacement Kit (12-8066-02), as follows.
2. Apply a film of grease (Mobiltemp SHC-32 or equivalent) to the surface of the accessible ball detents (8 places—4 on the drive collar and 4 on the bottom of the locking disc). Also apply a *thin* film of grease to the inner diameter of the locking disc bore. Do not let the grease contact any friction surfaces. Excess grease can contaminate the friction surface and reduce SLM effectiveness.
3. With the motor shaft pointed up, place a steel ball into each of the drive collar detents.
4. Install the subassembly, making sure the steel balls are properly seated in the detents of the drive collar.
5. Install the thrust bearing, then the stop collar as follows: Align the stop collar with the pen mark made during disassembly, then insert a 1/8" pilot punch through the stop collar hole and into the motor shaft to hold it in place.
6. Pushing down firmly on the pinion, measure the gap between the stop collar and the thrust bearing. This gap should measure $0.015 \pm .005$ ". This space is required to ensure proper operation. Add shims, if necessary. Install the new 1/8" spring pin while supporting the shaft.
7. Recoat the pinion gear teeth, spur gear teeth and other gearing accessible in the motor cavity with a layer of Mobiltemp SHC-32 or equivalent.
8. Reinstall the motor assembly (see page 40).



SLM
SUBASSEMBLY

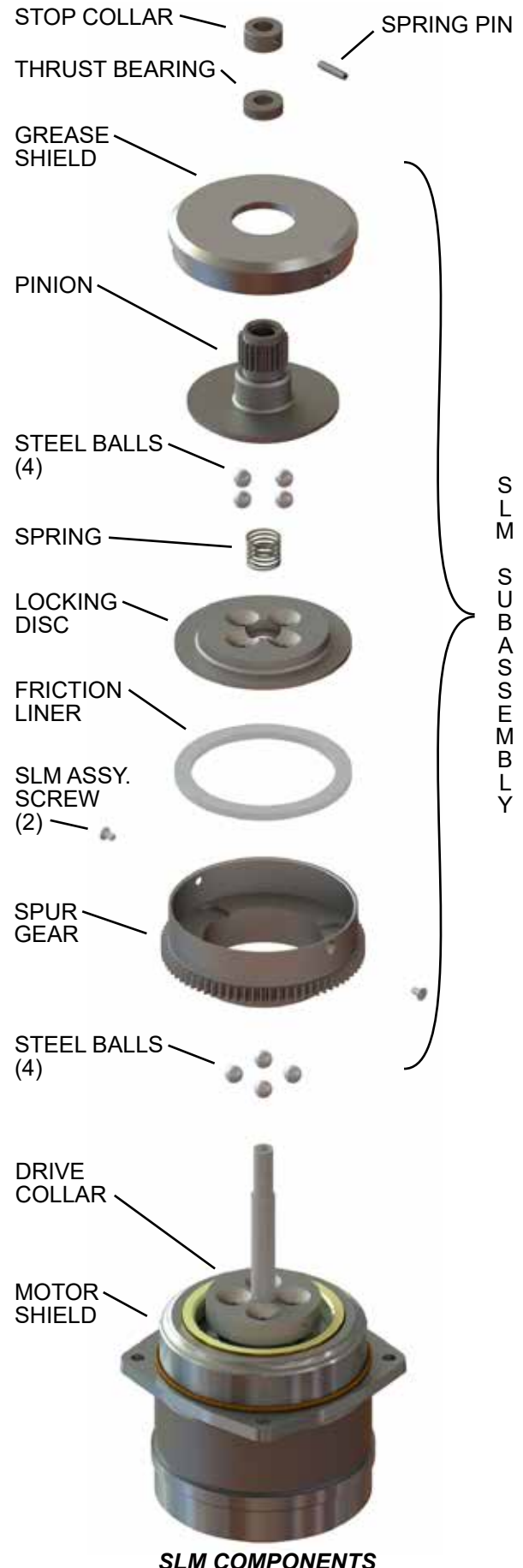

SLM COMPONENTS

OVER-TRAVEL LIMIT AND AUXILIARY SWITCHES

Complete switch assemblies may be replaced. It is not possible to replace individual switches. To replace switch assemblies, follow the instructions below.



WARNING
Electrical shock hazard. Disconnect power before proceeding.

Remove the top cover (see page 21).

Remove the screws holding the switch assembly to the switch plate (top and bottom) and slide it out to the side.

Transfer the wires to the terminals of the replacement assembly, ensuring the correct wire is transferred to the correct replacement assembly terminal (wires have push-on lugs). Install the replacement assembly and note that it rotates around one screw to permit an adjustment of the cam-to-switch lever spacing and switch operating point. To set the switch, place a .030" (.75 mm) shim between the cam and switch lever (see photo at right). The switch lever should be on the low or minimum radius portion of the cam when setting the switches. Position the switch assembly so that the switch is just actuated. DO NOT overstress the switch lever. Tighten both screws to 10 lb-in (1.1 N•m) torque (using the rectangular washer to cover the gap in the mounting plate) and remove the shim. When properly adjusted, the switch's cam actuated lever will remain in contact with the cam throughout the actuator travel.

ADDING AUXILIARY SWITCHES

If the actuator has two auxiliary switches, or no auxiliary switches, it is possible to add auxiliary switches in the field. Auxiliary switches are available as an assembly consisting of 2 or 4 switches. A Group 57 actuator may have up to four total auxiliary switches (see table at right for part numbers).

Install the new switch assembly and adjust according to the preceding instructions. Find the push-on lugs of the auxiliary switches cable assembly. Attach the wires from the cable assembly to the appropriate spades on each switch assembly (N.C. or N.O. & COM) according to the wiring diagram.

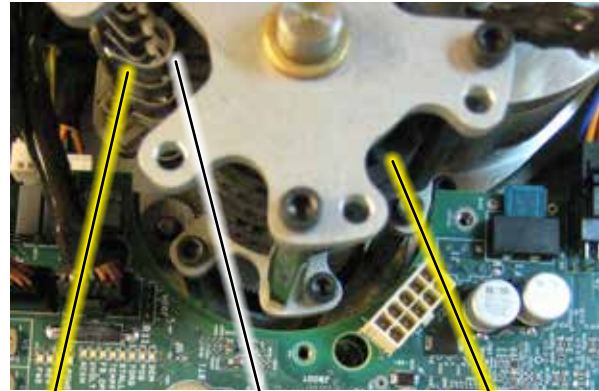

Switch
Lever

Cam

.030" (.75 mm) shim should be inserted between all levers and cams when setting switches.

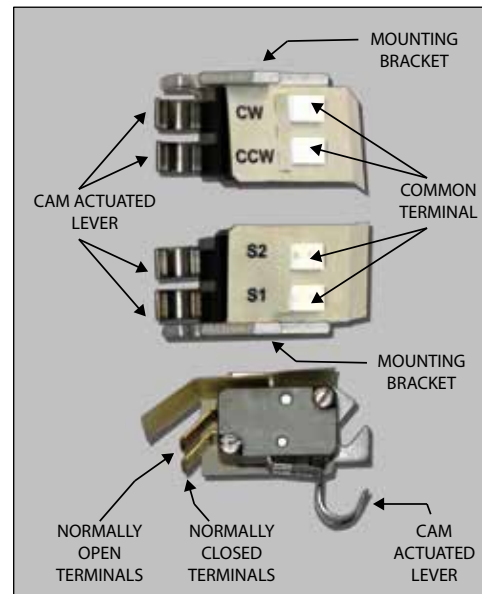

SWITCH PARTS

Description	Part Number
Over-travel limit switch assembly (CW/CCW)	20-3200-06
Auxiliary limit switch assembly, (2) switches (S1/S2)	12-8064-70
Auxiliary limit switch assembly, (4) switches (S1/S2/S3/S4)	12-8064-71
Limit switch cam assembly	11-0931-11
Cable assembly (limit switches)	20-0511-54
Cable assembly (aux. switches)	20-0511-58

MAINTENANCE

DCM BOARD

Field repair of the DCM board is not recommended. However, the board may be replaced in the field as per the instructions below.



WARNING
Electrical shock hazard. Disconnect power before proceeding.

Remove the existing DCM board:

1. Remove the top threaded cover (see page 21).
2. Disconnect all wire connectors, noting the locations for attachment to the new board.
3. Remove the (9) 6-32 x .25" Phillips head mounting screws securing the existing DCM board to the standoffs (see below).
4. Carefully lift the DCM board straight up and out of the actuator.

Install the new DCM board:

5. Carefully place the new board in the actuator, aligning the screw holes on the board with the standoffs.
6. Tighten the (9) 6-32 x .25" Phillips head mounting screws to 5 lb-in (.6 N•m).
7. Reconnect all wiring.

8. Replace the top threaded cover (see page 21).
9. Restore power to the actuator and verify proper operation. Perform Demand and Position calibration, if necessary.

DCM BOARD FUSE

The fuse for the DCM may be easily replaced in the field. Follow the instructions below.



WARNING
Electrical shock hazard. Disconnect power before proceeding.

1. Remove the top threaded cover (see page 21).
2. Remove the old fuse by pulling it straight out of the base.
3. Push the new fuse into the base.

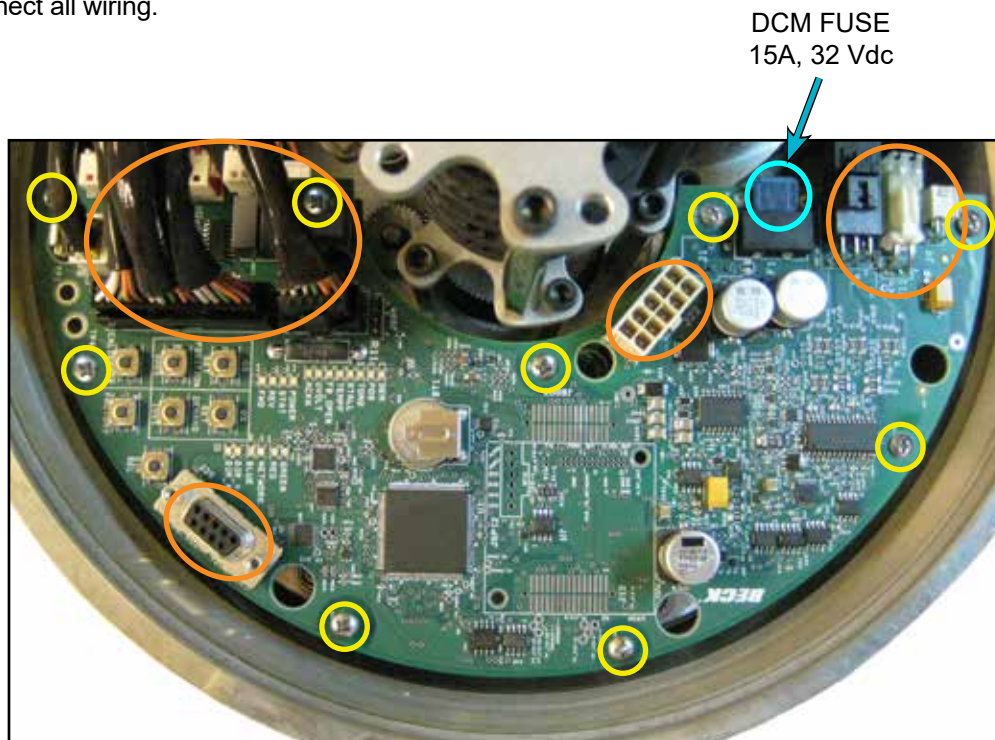

DCM BOARD

 = Mounting Screws (9 places)

 = Wiring Connections

CONTACTLESS (MAGNETIC VECTOR) POSITION SENSOR

The position sensor is not field-repairable. However, the sensor may be replaced in the field as per the instructions below. In most cases, the actuator will require position recalibration using the standard procedures described for all Beck Actuators using the Pushbutton, HART, Modbus or Serial interface (See the "TRAVEL (DEGREES ROTATION)" section on page 28). In most cases, recalibration can use the previous magnetic vector sensor limit values.

Occasionally, accurate recalibration is not possible with the previous magnetic sensor limit values and new values must be entered. The procedure for entering these new values is described in this section.

Once the new sensor limit values are entered, final position calibration should be performed.



WARNING

Electrical shock hazard. Disconnect power before proceeding.

Refer to the photos on this page for component identification and location.

Remove the existing sensor:

1. Remove the top threaded cover (see page 21).
2. Remove the wiring connector.
3. Remove the nut with a 5/8" ratchet.
4. Remove the metal plate.
5. Remove the nomex shield.
6. Remove the position sensor (keep the nomex shield beneath the position sensor in place).

Install the new sensor:

7. Position the new sensor chip side down over the threaded post.
8. Replace the nomex shield.
9. Replace the metal plate.
10. Reinstall the nut with a 5/8" ratchet and torque to 20 lb-in (2.3 N•m).

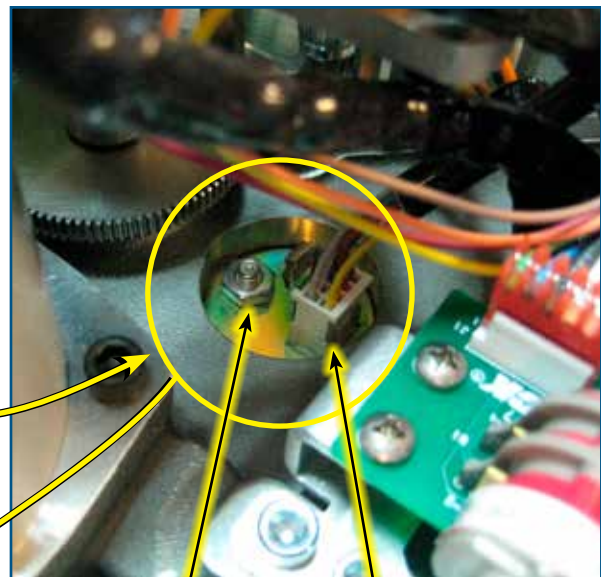

THREADED
NUT

WIRING
CONNECTOR

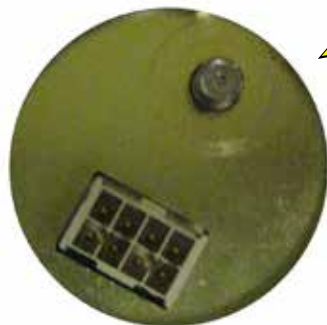

Metal Plate



Nomex Shield

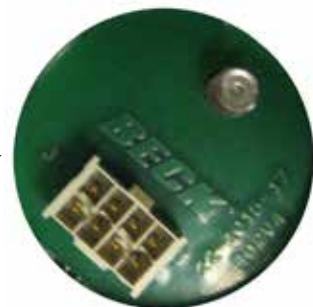

Position Sensor
(circuit side down)

MAINTENANCE

CONTACTLESS POSITION SENSOR, con't.

Enter New Magnetic Vector Sensor Limit Values:

11. Magnetic Vector Sensor Limit Values are only changed after it has been determined that a correct calibration cannot be achieved with the previous sensor limit values. Recalibrate the actuator using the steps outlined in the "TRAVEL (DEGREES ROTATION)" section. If a correct calibration is achieved, skip to step 29.
12. If the previous step was unsuccessful, use the FACTORY+POS0 and FACTORY+POS100 pushbuttons to restore the factory-configured sensor limit values. Recalibrate the actuator using the steps outlined in the "TRAVEL (DEGREES ROTATION)" section. If a correct calibration is achieved, skip skip to step 29.
13. If the previous step was unsuccessful, then the actual sensor limit values will have to be entered using Serial commands.
14. Place the Handswitch in STOP. With the new position sensor cable disconnected, turn on power to the actuator.
15. Move the Handswitch to the CCW position. The actuator will move at its slowest speed to the point where the CCW limit switch will stop the output shaft movement. Move the Handswitch back to STOP.
16. Turn the handcrank in the counterclockwise direction until it can no longer move the output shaft.
17. Then turn the handcrank in the clockwise direction eighteen (18) times. This establishes the working CCW limit of the position sensor.
18. Turn power off to the actuator. Reconnect the position sensor cable. Turn power back on to the actuator.
19. Use the Serial command "posism" to determine the present CCW sensor limit. The actual sensor count will be the second number reported. In the example below, the posism command reports a sensor count of **14418**.

```
DCM-5<3.58>posism
128 14418 8000 18ee 8000 a400 adb3
c000 800 aa 2601 2506651K 0 55839 3953
OK
DCM-5<3.58>
```

20. Use the Serial command "magcntsatposa" to enter this CCW sensor limit. Our example value 14418 read earlier would be entered as follows:

```
DCM-5<3.58>magcntsatposa 14418
```

```
Magnetic Position Sensor Counts At PosA:
14418
```

```
OK
DCM-5<3.58>
```

21. Turn power off to the actuator. Disconnect the position sensor cable. Turn power back on to the actuator.
22. Move the Handswitch to the CW position. The actuator will move at its slowest speed to the point where the CW limit switch will stop the output shaft movement. Move the Handswitch back to STOP.
23. Turn the handcrank in the clockwise direction until it can no longer move the output shaft.
24. Turn the handcrank in the counterclockwise direction eighteen (18) times. This establishes the working CW limit of the position sensor.
25. Turn power off to the actuator. Reconnect the position sensor cable. Turn power back on to the actuator.
26. Use the Serial command "posism" to determine the present CW sensor limit. Again, the actual sensor count will be the second number reported. In the example below, the posism command reports a sensor count of **6162**.
27. Use the Serial command "magcntsatposb" to enter this CW sensor limit. The example value of 6162 counts would be entered as follows:

```
DCM-5<3.58>posism
```

```
128 6162 8000 18ee 8000 9a00 89b3 c000
800 aa 2601 2507302K 0 3446 8711
```

```
OK
DCM-5<3.58>
```

```
DCM-5<3.58>magcntsatposa 6162
```

```
Magnetic Position Sensor Counts At PosB:
6162
```

```
OK
DCM-5<3.58>
```

28. Recalibrate the actuator using the steps outlined in the "TRAVEL (DEGREES ROTATION)" section.
29. Replace the top threaded cover (see page 21).

HANDSWITCH



WARNING

Electrical shock hazard. Disconnect power before proceeding.

REMOVE THE EXISTING HANDSWITCH:

1. Remove power from the actuator.
2. Remove the top threaded cover (see page 21).
3. Ensure the Handswitch knob is in a "STOP" position and loosen the two inset screws (5/64" hex wrench).
4. Disconnect the (2) wiring connectors.
5. Remove the (2) 6-32 x .25" Phillips head screws holding the Handswitch assembly to the bracket.
6. The Handswitch assembly may now be pulled away from and lifted out of the retaining bracket.

INSTALL THE NEW HANDSWITCH:

7. Insert the new Handswitch assembly into the retaining bracket (as shown at right) and slide forward until the screw holes in the Handswitch board align with the holes in the retaining bracket.
8. Insert the two 6-32 x .25" Phillips head screws into the holes and tighten to 5 lb-in (.6 N•m).
9. Reattach the two wiring connectors.

10. From the outside of the actuator, slide the Handswitch knob onto the shaft, ensuring that it is in the same STOP position as the old knob when it was removed. Tighten the two inset screws to 3 lb-ft (4 N•m).

11. Replace the terminal cover (see page 21).

NOTE: When the Handswitch is turned fully clockwise, "AUTO" should be indicated.

HANDSWITCH ASSEMBLY

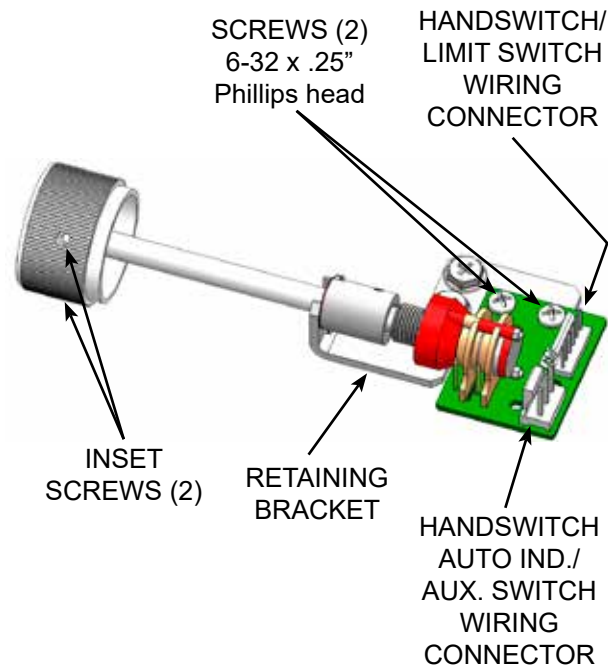

O-RINGS

During routine service, inspect removed O-rings for wear or damage. In order to protect internal components, worn or damaged O-rings should be replaced, as described below.

The Group 57 actuator has two user accessible O-rings (for the top cover and the terminal compartment cover) that are different sizes. Ensure the replacement O-ring is the correct size for its location.

Remove and discard the old O-ring(s). When installing the new O-ring(s), ensure that the ring is properly seated in the correct groove on the cover (farthest from the threads - see illustrations at right). Apply a light layer of Parker Super O-Lube (SLUBE 884-2) or equivalent. Carefully tighten the cover (see page 21).

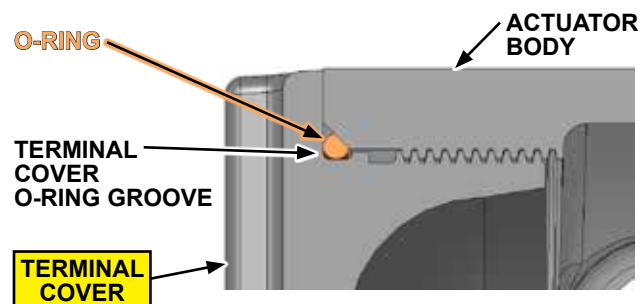
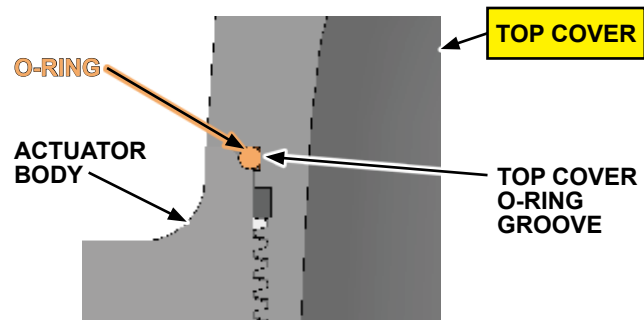

MAINTENANCE

RECOMMENDED SPARE PARTS

The table below lists the common recommended spare parts of the Group 57 actuator.

COMMON RECOMMENDED SPARE PARTS

Description	Part Number
DCM board	22-5015-19
Fuse, 15A, 32 Vdc (For use on DCM)	12-3542-18
Fuse, 1A, 600 Vac, Time Delay Class CC (AC Chassis Only)	11-1372-13
Position Sensor	22-5015-17
SLM Replacement Kit	12-8066-02
Overtravel limit switch assy. (CW / CCW)	20-3200-06
Auxiliary switch assy.	
2 switches (S1–S2)	20-3200-07
4 switches (S1–S4)	20-3200-08
O-ring kit	20-3157-02

TROUBLESHOOTING

The DCM features diagnostics to help troubleshoot problems.

The following list provides a systematic method for isolating any actuator problems.

1. Operating Voltage
2. Handswitch Operation
3. DCM Status Indication LEDs
4. DCM Testpoints
5. DCM Configuration
6. Shaft Position
7. Inhibitors / Statistics

VERIFY OPERATING VOLTAGE

To check the input power supply, view the Overview LEDs on the DCM board (see illustration on page 18). This requires removing the threaded top cover (see page 21).

The PWR LED should pulse from dim to bright, which indicates that power is applied to the actuator and the DCM is successfully completing (continuous) self-tests. If the PWR LED is not lit or pulsing, there may be a problem with the main power supply to the actuator.

Verify that the voltage reaching the DCM is correct by connecting the plus (+) lead of a DC Voltmeter to DCM Test Point 9 (TP9) and the minus lead (–) to Test Point 8 (TP8) as shown on the DCM Testpoint map (page 20). The DC Voltage between these two testpoints should be greater than 11 Vdc and less than 32 Vdc for both AC and DC models. When the actuator is in stop, this voltage should be steady.

For AC models, if the voltage at TP9/TP8 is zero, check the AC Fuse located below the DCM circuit board (See “DCM CHASSIS TYPES” section). If the voltage at TP9/TP8 is correct, verify that the DCM fuse at F1 is functional.

If the DC voltage between DCM TP9 and TP8 is varying excessively or out of specified limits, verify that the actuator is receiving the proper operating voltage (listed on the actuator nameplate). To check the voltage, locate the power terminals on the terminal block (see wiring diagram). Using a voltmeter, measure the voltage applied to those terminals. If the voltage is correct, continue troubleshooting; if the voltage is not correct, apply the proper power.

CHECK HANDSWITCH OPERATION

After confirming correct operating voltage, verify that the Handswitch can move the output shaft fully clockwise (CW position) and counterclockwise (CCW position). If the output shaft fails to move, check the following:

- Verify that the Handswitch cable is connected to Handswitch connector J1.
- Verify that the opposite end of the Handswitch cable is connected to DCM connector J10.
- Verify that the motor is connected to DCM connector J6.
- Verify that the CW and CCW limit switches are configured correctly.

CHECK DCM STATUS INDICATION LEDS

The DCM has seven Status Indication LEDs that provide specific information about the actuator's state (page 19). A lit LED indicates that a condition exists.

CHECK DCM TESTPOINTS

As mentioned previously, TP9 and TP8 are used to measure the DC Voltage supply to the DCM. Other test point pairs are described in the SIGNAL TEST POINTS section on page 20.

VERIFY CORRECT DCM OPERATION CONFIGURATION

Typically, the DCM is shipped preconfigured to customer specification. Should the configuration change or if it is unknown, take the following steps to verify the actuator setup:

- Determine the control interface setting: The Group 57 combines both HART/Analog and Modbus control capabilities in one DCM. Actuators configured for HART/Analog will not respond to Modbus commands and, conversely, actuators configured for Modbus will not respond to the Analog demand signal. The **network** Serial command is used to switch between HART and Modbus interfaces. The “network 0” Serial command activates the HART/Analog control interface. The “network 4” command activates the Modbus RTU interface.
- Determine the Operation Mode Setting: Once it is determined that the correct control interface has been selected, the operation mode can be determined using the following methods:

TROUBLESHOOTING

HART method

For the Actuator to respond to the Analog Demand signal, the “Op Mode” selection in the HART Operation Mode Menu (3E) should be set to “Follow”. The other modes—“Hold,” “RunCW,” “RunCCW,” “Stay” and “Stop”—are available for testing; however, the mode should be set to “Follow” before exiting this menu.

Serial command method

The Serial command “**opmode**” is used to set the operation mode. “opmode 0” sets the actuator to follow analog demand and should be set as a default value for HART/Analog interface actuators. For Modbus interface actuators, the “opmode 0” command will be rejected as the analog signal is switched off for Modbus operation.

“opmode 1” switches the actuator Demand source from the analog signal to a numeric value specified by the “**hold**” Serial command. For actuators configured for HART/Analog, the change to opmode 1 will cause a “Demand Detected Under Digital Control” alarm and the STAT LED will illuminate. HART/Analog Actuators should be changed back to “opmode 0” to clear this alarm. actuators.

opmodes 2 (move full CW), 3 (move full CCW), 4 (stay in position) and 5 (stop) are mainly used for test purposes. After testing has completed, the actuator should be set to opmode 0 (HART/Analog) or opmode 1 (Modbus) to match the actuator network configuration.

Modbus method

Modbus Holding Register 40014 will accept the same numeric values as the opmode Serial command. Setting Register 40014 to 1 will cause the actuator to move to the last entered setpoint. Any attempt to set Register 40014 to 0 (follow) will be rejected, as actuators configured for Modbus cannot follow an analog signal.

CHECK SHAFT SENSOR

The output shaft position sensor communicates continuously to the DCM. If the POS LED on the DCM is illuminated, verify that the cable between the sensor and the DCM J8 connector is installed correctly (see MAGNETIC VECTOR POSITION SENSOR section on page 45).

Use HART, Serial commands or Modbus to read the shaft position percentage and verify that it agrees with the actual position.

Verify that the limit switches do not impinge upon the configured travel span.

CHECK DCM INHIBITORS / STATISTICS

Conditions that prevent the DCM from positioning the actuator are called inhibitors. HART MENUS 5F and 5G list the CW and CCW inhibitors respectively. Inhibitors may also be reviewed by running the Serial command “stat” (see page 69). The following list indicates why the inhibitor would be in the “ON” state.

Balance

Demand and position are balanced.

Supervisory

DCM is initializing.

Stall

A stall condition has been detected.

OverTrq/Thr

Excessive torque load on output shaft.

Switch Block

Not applicable to Group 57 actuators.

Bad Pos Sig

The position signal is out of range.

Bad Dem Sig

The Demand signal is out of range.

Local Cal

The calibrate button is being pressed on the pushbutton panel.

The factory can assist with troubleshooting—please provide the results of the above review to expedite assistance.

CONDITIONS	POSSIBLE CAUSES	CORRECTIONS
1. No DCM LEDs are illuminated.	<ul style="list-style-type: none"> a. No power is applied to the actuator. b. Incorrect power is applied to the actuator. c. DCM malfunction. d. Fuse cleared. 	<ul style="list-style-type: none"> a. Apply operating voltage to the operating voltage terminals. Check the voltage between TP8 and TP9 and verify it is between 11 Vdc and 32 Vdc. b. Verify correct voltage on actuator nameplate and ensure that it is applied at the operating voltage terminals. Check the voltage between TP8 and TP9 and verify it is between 11 Vdc and 32 Vdc. c. Replace DCM. d. Use an ohmmeter to check the DC fuse at F1 on the DCM. For AC Chassis types, check the AC Fuse located under the DCM (see DCM FUSE LOCATIONS section on page 16).
2. STAT LED is illuminated.	<ul style="list-style-type: none"> a. A status alarm is active. 	<ul style="list-style-type: none"> a. Check the status indication LEDs on the DCM. Continue troubleshooting based on the LEDs that are illuminated.
3. DEM LED is illuminated.	<ul style="list-style-type: none"> a. No Demand signal. b. Applied Demand signal is outside of configured range. c. Polarity of applied signal wires is reversed. 	<ul style="list-style-type: none"> a. Apply a Demand signal to terminals 36 (+) & 35 (-). b. Confirm Demand signal value via HART or by measuring DC voltage across DCM test points TP3(+) & TP2(-). Should be 1–5 Vdc for 4–20 mA applied signal. c. Correct the polarity of the applied control signal wires on terminals 36 (+) & 35 (-).
4. POS LED is illuminated.	<ul style="list-style-type: none"> a. Position sensor limit values are incorrect. b. Position sensor malfunction. c. DCM malfunction. 	<ul style="list-style-type: none"> a. Verify that the position sensor limit values are correct using the procedure outlined on page 46. b. Replace position sensor. c. Replace DCM.
5. TORQ LED is illuminated (applicable only to actuators equipped with optional torque sensing).	<ul style="list-style-type: none"> a. Torque exceeding configured limit (typically over 115% of rated torque) is being applied to the output shaft. b. Torque Null and Torque Constant values are not set correctly. c. Torque cable not connected to DCM. 	<ul style="list-style-type: none"> a. Eliminate cause of excessive torque. b. Locate Torque Null and Constant values and set via HART or Serial port. c. Reconnect torque cable to DCM.
6. STALL LED is illuminated.	<ul style="list-style-type: none"> a. Actuator has stalled—unable to achieve desired position within the configured “STALL TIME”. b. The configured stall time is less than the configured Max Travel Time. 	<ul style="list-style-type: none"> a. Eliminate the obstruction and reset the stall by reversing direction on your Demand signal, cycling the power, or issuing the stall reset from HART or Serial command. b. Configure the stall time to exceed the Max Travel Time via HART or Serial command.
7. TEMPF LED is illuminated.	<ul style="list-style-type: none"> a. The measured temperature at the DCM is outside of the normal operating range (typically -58° to 185° F.). 	<ul style="list-style-type: none"> a. Protect the actuator from extreme temperatures below or above the operating range to eliminate the alarm.
8. FB_OPEN LED is illuminated.	<ul style="list-style-type: none"> a. The position Feedback circuit current loop is not complete. b. The position Feedback is enabled, but not in use. 	<ul style="list-style-type: none"> a. Ensure the device measuring the 4–20 mA Feedback is properly terminated on terminals 37 (-) and 38 (+) and is applying a 0–800 ohm load resistance. b. Disable Feedback via HART or Serial command; OR terminate the Feedback loop by applying a 0–800 ohm load resistance across terminals 37 and 40.

TROUBLESHOOTING

CONDITIONS	POSSIBLE CAUSES	CORRECTIONS
9. UVOLT LED is illuminated.	<ul style="list-style-type: none"> a. The applied operating voltage is outside of the tolerance (+10%/-15%) of the nameplate operating voltage. b. The DCM fuse is open. c. A component failure has occurred on the DCM. 	<ul style="list-style-type: none"> a. Apply the correct operating voltage to the actuator per the voltage stamped on the nameplate. b. Replace the open fuse, see page 44. c. Replace the DCM.
10. The actuator will only move at a very slow speed when using the Handswitch or override terminals.	<ul style="list-style-type: none"> a. The DCM does not detect a valid position signal from the position sensor. b. The max. travel time is set to a high value (max. allowable time is 150 seconds for the 57-109 and 400 seconds for the 57-209). 	<ul style="list-style-type: none"> a. Verify the position sensor connection. Use the posism Serial command to read the sensor value. If communications are OK, the posism Serial command should report 128 as the first number. b. Adjust max. travel time via HART (MaxTravelTm) or Serial (drvtiming) closer to the minimum (9 seconds for the 57-109 and 20 seconds for the 57-209).
11. All LEDs are illuminated or flashing.	<ul style="list-style-type: none"> a. A component failure has occurred on the DCM. 	<ul style="list-style-type: none"> a. Replace the DCM.
12. FWD or REV LED is illuminated, actuator is not moving, and there are no other status alarms.	<ul style="list-style-type: none"> a. Handswitch is in the STOP position. b. CW or CCW limit switch is open. 	<ul style="list-style-type: none"> a. Turn the Handswitch to the AUTO position. b. Verify limit switch is set outside of electrically calibrated limits & readjust or replace, if necessary.
14. Actuator will not hold position with Handswitch in STOP.	<ul style="list-style-type: none"> a. Self-Locking Mechanism (SLM) is damaged. 	<ul style="list-style-type: none"> a. Rebuild the SLM assembly, see page 41.
15. Actuator POWER LED is flashing, but does not respond to Demand signal, Handswitch or override terminals.	<ul style="list-style-type: none"> a. The emergency override STOP terminal (31) is connected to the common terminal (28). b. The safety shutoff circuit is damaged. c. The Handswitch is damaged. 	<ul style="list-style-type: none"> a. Remove the connection from terminal 31 to terminal 28. b. Contact the factory. c. Replace the Handswitch, see page 47.
16. HART communications cannot be established with the DCM.	<ul style="list-style-type: none"> a. The Device Description (DD) file is not installed. b. The HART communicator is not compatible with Beck equipment. c. The HART communications circuit on the DCM is damaged. 	<ul style="list-style-type: none"> a. Install the Beck MK-2 DD on your HART device. b. Utilize a compatible HART communicator or configure the actuator through the Serial port. c. Replace the DCM.
17. Position Feedback signal at terminals 37 and 38 remains constant or is erratic.	<ul style="list-style-type: none"> a. The position feedback circuit on the DCM is damaged. 	<ul style="list-style-type: none"> a. Replace the DCM.
18. POWER LED is pulsing bright to dim.	<ul style="list-style-type: none"> a. This is a normal condition indicating the processor is functioning. 	<ul style="list-style-type: none"> a. No action required.
19. Output shaft rotates opposite of desired direction when applying a 4–20 mA Demand signal.	<ul style="list-style-type: none"> a. The rotation direction is incorrectly configured. 	<ul style="list-style-type: none"> a. Configure the rotation direction using pushbutton, HART, or Serial method.
20. Modbus communications cannot be established with the DCM.	<ul style="list-style-type: none"> a. Communications failure, communications errors or other configuration problem. 	<ul style="list-style-type: none"> a. Follow the procedures in the “Modbus Troubleshooting” section beginning on page 96.

APPENDIX HART® Communication

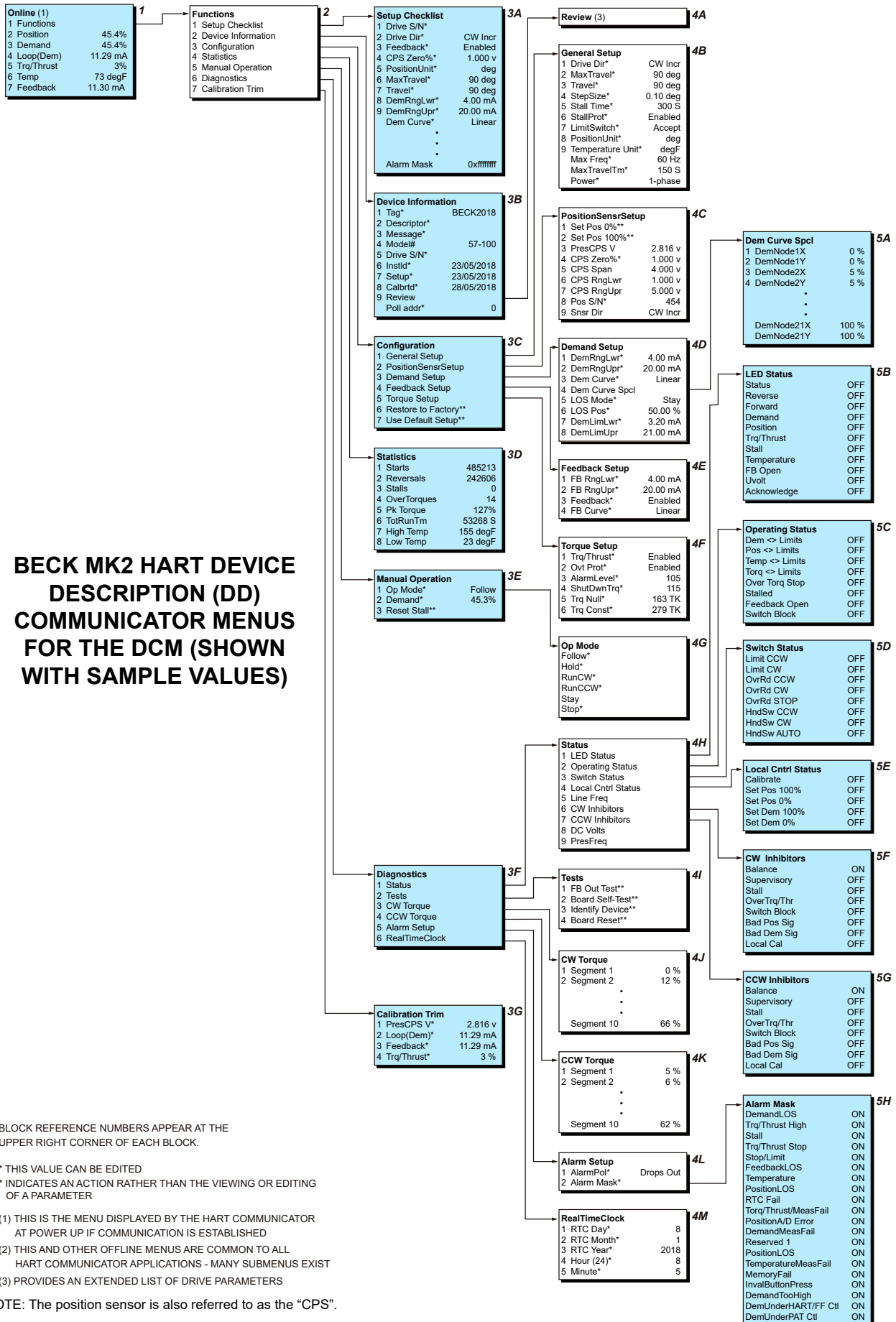

BLOCK REFERENCE NUMBERS APPEAR AT THE UPPER RIGHT CORNER OF EACH BLOCK.

* THIS VALUE CAN BE EDITED

** INDICATES AN ACTION RATHER THAN THE VIEWING OR EDITING OF A PARAMETER

(1) THIS IS THE MENU DISPLAYED BY THE HART COMMUNICATOR AT POWER UP IF COMMUNICATION IS ESTABLISHED

(2) THIS AND OTHER OFFLINE MENUS ARE COMMON TO ALL HART COMMUNICATOR APPLICATIONS - MANY SUBMENUS EXIST

(3) PROVIDES AN EXTENDED LIST OF DRIVE PARAMETERS

NOTE: The position sensor is also referred to as the "CPS".

APPENDIX HART® Communication

The DCM board is the control center of the actuator—configuration and calibration are accessed and set through the DCM board. Using the HART interface requires a HART compatible communicator or any device, computer or controller capable of communicating with HART devices and supporting the Beck DCM Device Description.

HART® INTERFACE

The interface menu tree for communicating with a DCM using the BECK-MK2 Device Description is located on the previous page. This menu tree summarizes possible setup options, features and available information.

HART® COMMUNICATORS FOR BECK-MK2

The BECK-MK2 Device Description requires a HART Communicator that is HART 5 capable and has the ability to import Device Description Language Files (DDL) that are certified by the HART Communications Foundation.

USING THE HART® COMMUNICATOR

The HART Communicator leads should be connected in parallel with the analog Demand signal wiring (see below). This allows the communicator to simultaneously communicate over the analog input wires. This does not disturb the analog Demand signal, or disrupt the DCM functions. However, any program changes to the DCM will momentarily suspend the operation of the board (maintains last state) while the change is implemented. Typically, this is only for a second or two.

After connected, turn on the communicator and wait for communications to be established. When communications are established, the “Online” display will appear. If the actuator is multidropped with other devices on a HART network, the first display screen will list all devices and require a selection before the “Online” display is shown. Follow the HART DD menu on the previous page to navigate.

NOTE: If the communicator is unable to communicate with the DCM, it displays the message, “No Device Found”. If this occurs, check to make sure the leads are securely connected to the Demand wiring and retry. If communications still do not occur, the communicator polling setup may be improperly set. Check the “utility” menu and make sure communications polling is set to “always poll”.

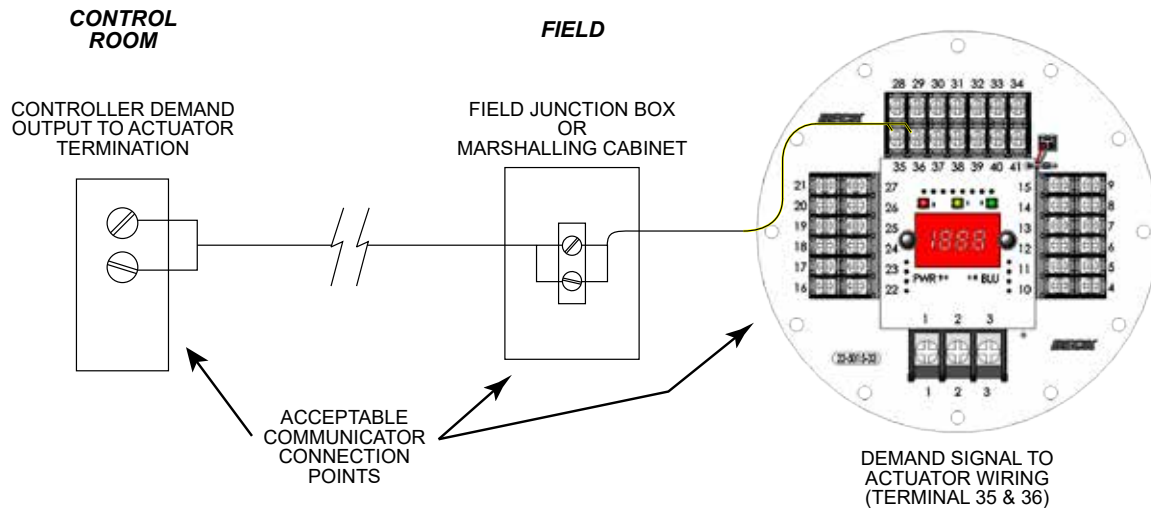

MENU DESCRIPTIONS

(See HART Communicator Menu on page 53)

MENU 1 -- Online

When communications are established, the Home Menu is displayed.

- 1 Functions:** The link to the menu tree.
- 2 Position:** The output shaft position displayed as a percent of range.

- 3 Demand:** The Demand signal displayed as a percent of range.
- 4 Loop (Dem):** The Demand signal measured in mA.
- 5 Trq/Thrust:** The present torque value as applied to the output shaft (optional).
- 6 Temp:** The ambient temperature of the DCM.
- 7 Feedback:** The milliamp output signal representing the present position of the output shaft.

MENU 2 -- Functions

From the Functions menu, any of the DCM menus can be accessed. The menus are organized categorically as follows: Setup Checklist, Device Information, Configuration, Statistics, Manual Operation, Diagnostics, and Calibration Trim.

MENU 3A -- Setup Checklist

The Setup Checklist provides a quick way for the user to setup the key items necessary for basic actuator operation without having to access any other menus.. These items are defined on the following pages in their specific menu locations.

MENU 3B -- Device Information

The Device Information menu provides information about the actuator. These useful information entries may be viewed and/or edited.

- 1 Tag:** An 8 character entry that can be used to identify a specific field device label.
- 2 Descriptor:** A 16 character field that can be used to provide any description desired.
- 3 Message:** A 32 character field that can be used to provide any message desired.
- 4 Model#:** Displays the model number of the actuator in which the DCM is installed. This field may be edited. Note that changing this field may cause the "Use Default Setup" command to not function.
- 5 Drive S/N:** The Serial number as shown on the actuator nameplate. When configured, this will automatically change the actuator model number (see previous item).
- 6 Instld:** Installation date of the actuator or DCM.
- 7 Setup:** The setup date has no affect on actuator operation.
- 8 Calbrtd:** The calibration date has no affect on actuator operation.
- 9 Review:** Link to the Review menu.
- 10 Poll addr:** Used to find the actuator. Most configurations should use "0".

MENU 4A -- Review

The Review menu displays many of the configured parameters in a read-only format. This menu may help ensure that the DCM is configured as desired.

MENU 3C -- Configuration

The Configuration menu serves as the gateway to all of the operating parameters that can be used to configure the actuator based on the desired operation.

- 1 General Setup:** Link.
- 2 PositionSensrSetup:** Link.
- 3 Demand Setup:** Link.
- 4 Feedback Setup:** Link.
- 5 Torque Setup:** Link.
- 6 Restore to Factory:** Restores field-configurable parameters back to the settings in effect when the DCM was shipped from the factory.
- 7 Use Default Setup:** Changes the DCM position sensing voltage ranges to the proper ranges for the actuator model.

MENU 4B -- General Setup

This menu sets actuator operating parameters. The nine parameter entries are as follows:

- 1 Drive Dir:** The direction the output shaft rotates (looking into the output shaft) in response to an increasing Demand signal.
- 2 MaxTravel:** The maximum travel distance of the output shaft in degrees. This number corresponds to the actuator design—if the correct Serial Number is entered, this parameter is 90° (or 100° if model 57-209 and customer specified) and should not be changed.
- 3 Travel:** The number of degrees of output shaft travel for 100% span (60–90°, 57-109 or 60–100°, 57-209).
- 4 StepSize:** The smallest Demand change that will cause an output shaft movement (0.1%–2.5%).
- 5 Stall Time:** The amount of time the motor will run (30–300 seconds) before Stall Protection is initiated and power disabled to the motor.
- 6 StallProt:** This entry is set as either "Enabled" or "Disabled".
- 7 LimitSwitch:** Set as either "Accept" or "Alert". Defines whether or not contacting an overtravel limit switch outside of the normal 0% to 100% travel range causes an alarm condition.
- 8 PositionUnit:** The numeric unit of measure for the output shaft position in angular degrees.
- 9 Temperature Unit:** The unit of measure for temperature sensing. May be "degF" (fahrenheit) or "degC" (celsius).
- 10 Max Freq:** Maximum allowed motor power frequency. This is factory set and should not be changed.

APPENDIX HART® Communication

MENU 4B -- General Setup (cont'd)

- 11 MaxTravelTm:** The time required for the actuator to travel (90°) between the limits (9–150 seconds for model 57-109 and 20–400 seconds for model 57-209).
- 12 Power:** “1-phase”.

MENU 4C -- PositionSensrSetup

This menu includes parameters from the contactless magnetic vector position sensor (also referred to as the “CPS”) that the DCM interprets as voltage equivalents.

- 1 Set Pos 0%:** Sets the 0% position to match the present output shaft position. This does not change the 100% position.
- 2 Set Pos 100%:** Sets the 100% position to match the present output shaft position. Also instructs the DCM to change travel span in relation to the 0% position. This does not change the 0% position.
- 3 PresCPS V:** Displays the CPS signal voltage at the present output shaft position. Not editable.
- 4 CPS Zero%:** Displays the CPS voltage at the 0% output shaft position. May be edited to define the voltage at the lowest operating point of travel. For CW actuator configuration, this voltage should be 1.0 V and for CCW configuration, 5.0 V. The DCM will automatically adjust when the direction of travel is changed.
- 5 CPS Span:** Displays the voltage signal span from the CPS for maximum possible rotation of the output shaft. This is the upper range voltage minus the lower range voltage (typically 4.0 V). Not editable.
- 6 CPS RngLwr:** Displays the CPS voltage signal at the lowest possible point of travel. Not editable.
- 7 CPS RngUpr:** Displays the CPS voltage signal at the highest possible point of travel. Not editable.
- 8 Pos S/N:** Displays the Serial number of the CPS and has no effect on actuator function.
- 9 Snsr Dir:** The direction of output shaft rotation that causes the CPS signal to increase. This direction is typically CW and is not editable.

MENU 4D -- Demand Setup

The parameters on this menu determine the range and characterization of the Demand signal. It also includes parameters that determine behavior when the Demand signal is absent.

- 1 DemRngLwr:** Sets and displays the signal value in mA that represents 0% Demand (default is 4.00 mA, minimum is 0.5 mA). This value should be set above “DemLimLwr”.
- 2 DemRngUpr:** Sets and displays the signal value in mA that represents 100% Demand (default is 20.00 mA, maximum is 21.00 mA). This value should be set below “DemLimUpr”.
- 3 Dem Curve:** Determines the relationship between the Demand signal and the position of the output shaft. Typically set to Linear, but may also be set to Square, Square Root or customized Special Curve.
- 4 Dem Curve Spcl:** Link to the “Dem Curve Spcl” menu.
- 5 LOS Mode:** Action on loss of Demand signal.
- 6 LOS Pos:** If the “LOS Mode” has been set to “Go-to-Pos”, this defines where the output shaft will move (in percent of travel) during loss of Demand signal conditions.
- 7 DemLimLwr:** Sets the threshold (in mA) below which the Demand signal is considered lost. This value should be set below “DemRngLwr”.
- 8 DemLimUpr:** Sets the threshold (in mA) above which the Demand signal is considered invalid. The Demand alarm will activate until the signal is brought below this level. This value should be set above “DemRngUpr”.

MENU 5A -- Dem Curve Spcl

This menu allows setting the Demand signal characterization curve.

MENU 4E -- Feedback Setup

This menu is where all the Feedback signal related actuator parameters are set.

- 1 FBRngLwr:** The value of the Feedback signal (in mA) that corresponds to a 0% output shaft position. This value can range between 3.00 mA and 16.00 mA (default = 4.00 mA).
- 2 FBRngUpr:** The value of the Feedback signal (in mA) that corresponds to a 100% output shaft position. This value can range between 7.00 mA and 21.00 mA (default = 20.00 mA).
- 3 Feedback:** Enables or Disables the Feedback signal.
- 4 FB Curve:** Allows a choice in the relationship between the applied Feedback signal and the actual position of the actuator. Choices are: Linear & Inverted Demand (“InvDem”).

MENU 4F -- Torque Setup

This menu is where all the Torque related actuator parameters are set.

- 1 Trq/Thrust:** Enables or disables torque sensing.
- 2 Ovt Prot:** Enables or disables overtorque protection which will remove power from the motor if excessive torque is detected.
- 3 AlarmLevel:** Sets the value that, if exceeded, will cause the Torque Alarm to activate (20–105%).
- 4 ShutDwnTrq:** Sets the output shaft torque in percentage of actuator rating that, if exceeded, removes power from the motor (25–115%).
- 5 Trq Null:** The torque sensor value that represents 0% output shaft torque. This value is unique for each actuator and may be found on a label inside the actuator.
- 6 Trq Const:** The internal DCM signal span associated with the output shaft torque. This value is determined during manufacture and is noted on a label inside the actuator.

MENU 3D -- Statistics

This menu is where all the actuator's stored operating statistics are available.

- 1 Starts:** The total number of motor starts.
- 2 Reversals:** The total number of times the motor has started in the direction opposite to the previous start.
- 3 Stalls:** The total number of times the stall time has been exceeded.
- 4 OverTorques:** The total number of times that excessive torque was detected at the output shaft.
- 5 Pk Torque:** The highest recorded torque on the output shaft.
- 6 TotRunTm:** Total amount of time the motor has been powered (in seconds).
- 7 High Temp:** Highest temperature recorded in the DCM compartment (in degrees fahrenheit).
- 8 Low Temp:** Lowest temperature recorded in the DCM compartment (in degrees fahrenheit).

MENU 3E -- Manual Operation

This menu is used to allow manual operation using HART® communications. There are three manual operation procedures available:

- 1 Op mode (Menu 4G):** Selects the operating mode of the DCM. There are six possible choices: "Follow", "Hold", "RunCW", "RunCCW", "Stay" and "Stop". "Follow" mode is the normal state of operation and allows the DCM control in response to the analog input Demand signal. "Hold" mode forces the DCM to position according to the HART Demand value (see right). "RunCW" mode forces the actuator to move CW. "RunCCW" forces the actuator to move CCW. The "Stay" mode forces the actuator to maintain its present position. Note that in "Stay" mode, the Handwheel cannot be freely turned. The "Stop" mode removes power from the motor. Note that in "Stop" mode the Handwheel can be freely turned. Note that the Handswitch overrides all operating modes.
- 2 Demand:** This procedure sets the effective Demand signal. If "Op mode" is set to "Hold", entering a valid value (-5% to 105%) will control the motor. If "Op mode" is set to "Follow", the analog Demand signal is displayed (unless an alarm condition exists).
- 3 Reset Stall:** This procedure resets normal actuator operation after a stall condition has caused the motor to shut down. Note that stall conditions can also be reset by simply reversing the input Demand signal or cycling the actuator AC power.

MENU 3F -- Diagnostics

Provides paths to menus that allow investigation of actuator problems through status indicators, self-test routines, output shaft loading history, alarm setup and setting of the DCM real time clock. Menu item links are "Status", "Tests", "CW Torque", "CCW Torque", "Alarm Setup", and "RealTimeClock".

MENU 4H -- Status

This menu provides links to menus that monitor the operational status of the actuator. It also displays one parameter, line frequency.

- 5 Line Freq:** The power line frequency as measured by the DCM.

APPENDIX HART® Communication

MENU 5B -- LED Status

The LED Status parameter allows remote checking of which LEDs on the DCM are illuminated.

MENU 5C -- Operating Status

The Operating Status parameter is a summary of whether process-related conditions are inside or outside of anticipated limits. These conditions control the Status Indication LEDs. Each parameter is listed with an ON or OFF state. The ON state is described below.

- 1 Dem <> Limits:** Caused by the Demand signal falling below or above acceptable levels.
- 2 Pos <> Limits:** Caused by the CPS signal being outside the range anticipated by the DCM.
- 3 Temp <> Limits:** The ambient temperature of the DCM is outside of the rating.
- 4 Torq <> Limits:** Measured torque exceeds the configured alarm level.
- 5 Over Torq Stop:** Overtorque protection is preventing the DCM from running the motor.
- 6 Stalled:** A Stall alarm is active.
- 7 Feedback Open:** The Feedback signal is enabled, but cannot follow the proper current.
- 8 Switch Block:** The DCM cannot power the motor due to an electro-mechanical switch. Check the Handswitch and over-travel limit switches.

MENU 5D -- Switch Status

Each parameter will be listed with an ON or OFF state. The ON state is described below.

Limit CCW: The CCW over-travel limit switch has been reached.

Limit CW: The CW over-travel limit switch has been reached.

OvrRd CCW: The CCW manual override terminal (30) is shorted to the common (28).

OvrRd CW: The CW manual override terminal (29) is shorted to the common (28).

OvrRd STOP: The STOP manual override terminal (31) is shorted to the common (28).

HndSw CCW: The Handswitch is in the CCW position.

HndSw CW: The Handswitch is in the CW position.

HndSw AUTO: The Handswitch is in the AUTO position.

MENU 5E -- Local Cntrl Status

This parameter allows remote monitoring of which buttons on the local configuration interface are being pressed.

MENU 5F -- CW Inhibitors

Allows viewing of the DCM condition that is preventing the actuator motor from running in the CW direction.

MENU 5G -- CCW Inhibitors

Allows viewing of the DCM condition that is preventing the actuator motor from running in the CCW direction.

MENU 4I -- Tests

This menu provides access to some routines that help determine if the actuator is functioning properly.

- 1 FB Out Test:** Allows manual verification of the Feedback output signal to check operation and accuracy.
- 2 Board Self-Test:** Instructs the DCM to check various power and sensing circuits. This test will cause the actuator to reposition, so it should be run offline and only when a DCM problem is suspected.
- 3 Identify Device:** Causes the ACKN LED on the DCM to flash for two seconds. Ensures the HART system is addressing the correct actuator.
- 4 Board Reset:** Causes the DCM to initiate a reset cycle similar to a power-up reset. This manual reset will cause the actuator to reposition. This procedure is not typically necessary.

MENU 4J -- CW Torque

This menu displays the peak output shaft torque measured for 10 segments. These torque values are measured with the motor running and moving the output shaft CW.

MENU 4K -- CCW Torque

This menu displays the peak output shaft torque measured for 10 segments. These torque values are measured with the motor running and moving the output shaft CCW.

MENU 4L -- Alarm Setup

The Alarm Setup menu parameters allow modification of the behavior of the alarm.

- 1 **AlarmPol:** Whether the solid state relay opens on alarm or closes on alarm.
- 2 **Alarm Mask:** Link to the Alarm Mask menu which allows specific alarm conditions to be ignored.

MENU 5H -- Alarm Mask

Allows selection of alarm conditions that will not cause an alarm.

MENU 4M -- RealTimeClock

This menu allows the date and time to be set.

- 1 **RTC Day:** Day of the month (numeric value).
- 2 **RTC Month:** Month (numeric value).
- 3 **RTC Year:** Year (4 digits).
- 4 **Hour (24):** Hour of the day (24 hour format).
- 5 **Minute:** Minute of the hour (0 through 59).

MENU 3G -- Calibration Trim

The Calibration Trim menu sets and displays actuator calibration values. **Note that changing the calibration trim can cause signal measurement difficulties if performed improperly.**

- 1 **PresCPS V:** Displays and/or trims the present voltage of the position signal. This value may also be measured at DCM test points TP1(-) and TP4(+). This trim is set and tested at the factory. Changing this value can cause voltage measurement errors.
- 2 **Loop(Dem):** Displays the Demand signal as measured at terminals (35 & 36). When the Demand control loop signal is being overridden by a special mode of operation, the effective Demand will not correspond to the mA value. This value can be edited to trim the Demand to ensure accurate measurement of the analog signal. Demand can only be trimmed at 4.0 mA and 20.0 mA.
- 3 **Feedback:** Displays the mA signal representing the output shaft position as measured at terminals (37 & 38). This value can be edited.
- 4 **Trq/Thrust:** Displays the load measured at the output shaft as a percentage of rated torque. This is also a short cut to set the 0% torque parameter ("Trq Null") by removing load from the output shaft, then setting this value to "0".

APPENDIX HART® Messages

COMMON HART® MESSAGES

HART® protocol maintains both standard and device specific informational messages that are displayed on the Communicator when various conditions occur.

Below is a table of typical Beck actuator messages and message sequences. It does not include all possible messages, only the most common.

Output Shaft Position Measurement Messages

Message	Description
"Process applied to the primary variable is outside the operating limits of the field device."	This is a standard HART-defined message that appears whenever the HART primary variable (Position signal) is outside the design or calibrated range. This message should be accompanied by a Beck-specific message with more detail.
"The Position Signal is less than -5% or greater than 105%."	This Beck-specific message indicates the DCM is reading a Position signal not within the calibration range limits.
"Position signal in LOS."	This is a Beck-specific message. The DCM is indicating that the Position signal is a problem and is intended to identify a position sensor or wiring failure. This is triggered when the Position signal is outside the minimum and maximum voltage limits.
"Position out of accurate measurement range."	This is a Beck-specific message. The DCM indicates the Position signal is outside of the design range.
"Position sensing error."	This is a Beck-specific message. The DCM circuitry for measuring the Position signal does not appear to be functioning properly.
"Analog output 1 and its digital representation are outside the operating range limits, and not responding to input."	This is a standard HART-defined message that appears whenever the position signal to the DCM is outside the design or calibrated range. This message should be accompanied by a Beck-specific message with more detail.

Handswitch and Over-travel Limit Switch Message

Message	Description
"Motor power is blocked, check switches."	This message will appear if the DCM detects a condition that prevents current flow to the motor.

Stall Protection Message

Message	Description
"Stall condition has been detected (see 'Stall Time' in the 'General Setup' menu)."	This is a Beck-specific message indicating that the actuator is in a stalled condition. This occurs if the actuator cannot reach the Demand position in the time allotted by the stall time setting (configurable from 30–450 seconds).

Demand, Torque and Temperature Measurement Messages

Message	Description
"Process applied to the non-primary variable is outside the operating limits of the field device."	This is a standard HART-defined message that appears whenever the Demand signal or Temperature are outside their design or calibrated ranges. This message should be accompanied by a Beck-specific message with more detail.
"The Demand Signal is outside of the intended limits (see Demand Setup menu)."	This Beck-specific message indicates the Demand signal is invalid.
"Demand out of accurate measurement range."	This is a Beck-specific message that the Demand signal is not only out of the calibrated range, but also out of the design range of the actuator. The lower and upper limits are 0.1 Vdc and 5.5 Vdc, respectively. Note that current input DCM boards utilize a 250 Ohm input resistor to convert the current signal to voltage.
Demand Signal is out of limit.	This Beck-specific message indicates the Demand signal is too high to measure accurately. The upper limit is 5.5 Vdc. Note that current input DCM boards utilize a 250 Ohm input resistor to convert the current signal to voltage.
Demand sensing error.	This is a Beck-specific message. The Demand sensing circuitry does not appear to be functioning properly.
The Torque/Thrust is greater than the output rating.	This Beck-specific message defines an output shaft torque overload problem.
Motor power has been removed due to excessive output torque.	This Beck-specific message indicates the DCM has removed power from the motor due to excessive output shaft torque load. The Handswitch must be in AUTO mode for this alarm to be accurate.
Torque/Thrust out of accurate measurement range.	This is a Beck-specific message. The DCM is not able to read a valid signal from the Torque sensor.
Torque/Thrust sensing error.	This is a Beck-specific message. The DCM circuitry for measuring the Torque signal does not appear to be functioning properly.
The temperature is outside of -58°F to 185°F.	This is a Beck-specific message indicating that the temperature at the DCM is outside of the acceptable range.
Temperature out of accurate measurement range.	This is a Beck-specific message. The DCM ambient temperature reading is extreme and cannot be accurately measured.
Temperature A/D Fail.	This is a Beck-specific message. The DCM circuitry for measuring the ambient temperature does not appear to be functioning properly.
The Feedback Signal is enabled but the loop is open.	This is a Beck-specific message indicating that the Feedback sourcing circuit is unable to create the proper signal current. This message could result from the signal not being wired to an external load, or a wiring failure has occurred at some point between the actuator and the monitoring device.

APPENDIX HART® Messages

Configuration Problem Related Messages

Message	Description
Analog output 1 and its digital representation are in fixed mode, and not responsive to input changes.	Standard HART-defined message that appears whenever the Feedback signal has been manually assigned a value. This message should be accompanied by a Beck specific message with more detail.
Feedback is in fixed mode.	A Beck-specific message indicating that the Feedback signal has been manually set to a fixed value and is not following the Position value.
Local control button pressed while locked-out.	A Beck-specific message indicating an incorrect combination of pushbuttons is being pressed on the local configuration interface, or the local control interface is disabled and a pushbutton is being pressed.
Loop Current Detected while under HART/FF Control.	A Beck specific alarm message that alerts the user that analog current is present on the Demand terminals, but the DCM is in an Op Mode expecting digital control. Make certain the Op Mode parameter is set properly.
Loop Current Detected while set for LOS PAT.	A Beck specific alarm message that alerts the user that analog current is present on the Demand terminals, but the DCM is set to a LOS mode intended to be used without an analog signal.

DCM Failure Messages

Message	Description
Real-time Clock hardware failure.	This is a Beck-specific message. The data in the Real-time Clock appears invalid.
FRAM Memory has failed.	A Beck-specific message. The continuous built-in self-test cannot verify the memory for statistics information is operating properly.
Memory failure.	This is a Beck-specific message. The continuous built-in self-test cannot verify the microcomputer is operating properly.

Miscellaneous HART-Defined Messages

Message	Description
Field device has more status available.	This is a standard HART-defined message that appears whenever the DCM signals HART that an alarm or other undesirable status exists. This is the HART protocol mechanism for displaying the other messages in this section. If this message is displayed without additional details, the status cleared before HART read the additional status.
A reset or self-test of the field device has occurred, or power has been removed and reapplied.	This message is displayed when the DCM has gone through a power-up reset sequence since the last communication. This message is only displayed once after a reset.
A modification has been made to the configuration of the field device.	This message indicates that the DCM has undergone a configuration change since the last time the HART change flag was reset.
Field device has malfunctioned due to a hardware error or failure.	This message indicates that the continuous built-in self-test cannot verify the microcomputer is operating properly.

APPENDIX *Serial Communication*

COMMUNICATIONS

Local configuration of the Beck actuator can be accomplished using Serial commands through the DCM Serial port.



CAUTION

Changes made to the actuator through Serial communications may not necessarily be reflected in asset management systems. Be sure to verify any changes made Serially and make manual corrections to the asset management system if necessary.

The Beck Digital Control Module (DCM) is equipped with a Serial interface which allows for direct communication with a computer. Using a standard DB9 to USB cable, connect the DCM to the computer using the DCM's DB9 connector (see below for location) and one of the computer's USB ports. Note: If your computer is equipped with an active COM port, a DB9 to DB9 cable may be utilized. See below for part numbers of cables available from Beck.

Once connected, communication can be established between the DCM and the computer using a terminal emulation program, such as HyperTerminal®. This method of communication will allow for configuration, calibration and verification of actuator DCM settings without the use of custom software applications.



DB9
Connector

HyperTerminal® SOFTWARE

HyperTerminal is the standard ASCII terminal emulation software provided with Microsoft® Windows®. If using HyperTerminal®, the following instructions will assist in setup. Note that some variation to these instructions may be necessary depending on the version of HyperTerminal® being used.

After connecting the DCM to the (Windows®-based) computer, access HyperTerminal® by clicking first on "Start", then "Programs", then "Accessories", then "Communications", then "HyperTerminal". Double-click on the "Hypertrm.exe" icon to start the program. Once HyperTerminal® is running, it is necessary to set up a file with the proper settings to communicate with the DCM. Proceed as follows:

1. If prompted to install a modem, answer "no". Proceed to enter a name (e.g., "DCM") and select an icon (any will suffice) in the "Connection Description" box. Click the "OK" button.
2. The "Connect to" box should open next. At the bottom of the box, set the "Connect using" selection to the appropriate USB (or COM) port that has been connected to the DCM. Click the "OK" button.
3. The port properties box should open next; this is where the communication settings are established. The correct settings are:
 - a. Bits per second = "9600"
 - b. Data bits = "8"
 - c. Parity = "none"
 - d. Stop bits = "1"
 - e. Flow control = "none"
4. With the appropriate settings entered from Step 3, above, click "OK". Communications should now be enabled.
5. Press the "Enter" key twice. "OK" should be displayed indicating that HyperTerminal® is communicating with the DCM.

Beck Serial Communications Cables



DB9 to USB-A
P/N 20-0511-60



DB9 to DB9
P/N 20-0511-14

APPENDIX *Serial Commands*

COMMANDS AND ARGUMENTS

Commands can be used for a variety of functions including changing the operating configuration of the actuator, verifying operation settings, calibration and accessing diagnostic information. There are essentially four different types of commands:

1. Dual-purpose commands. These commands can be used to either modify actuator configuration settings or display the settings already set in the actuator. In order to set or make a change to the settings, the command requires an argument (*n*). If the command is used for display purposes only, the argument is omitted. Examples of these commands include "temperature" and "demlos".
2. Display only commands. These commands are used to display diagnostic or operating information such as present signal values. No arguments are required. Examples include the "stat" command and the "signals" command.
3. Set only commands. These commands serve only to make a parameter change. Typically, they apply to the actuator calibration. This type of command requires an argument, but unlike dual-purpose commands, they return an error message when entered without an argument. Examples include the "charset" and "trimfdbk4mA" command.
4. Execute action commands. These commands serve to reset, enable or disable features. Entering these commands produces an immediate action. Examples include the "reset" and "restoremodes" command.

The available commands are listed on the next several pages and each is described in detail. The command description explains the use or uses of the command, while the argument column describes any applicable arguments. Arguments are denoted as *n*. Note that the commands described as "sets and/or displays" signify dual-purpose commands that can be used with or without an argument for setting or verifying configuration settings.

The following is a categorized list of Serial commands available through the DB9 interface. These commands are described in detail on the pages that follow.

Output Shaft Position Sensing Commands		
cpsvat0pct	travel	magcntsatposa
magcntsatposb		

General Configuration Commands		
alarmout	alarmoutmask	configformodel
drvdir	limitalarm	opmode
restoremodes	sernum	stallprot
stalltime	stepsize	drvtiming
relayconfig		

Torque Sensing Commands		
ovtstop	ovtstoplevel	torq
torq0k	torq0pct	torqalarm
torqconst	torqenable	torqprof

Communications Configuration Commands		
network	polladdr	modpolladdr
harttype	modbaud	modparity

Diagnostic and Information Commands		
demsources	help	ledtest
reset	signals	stat
temperature	uninstall	posism

Demand Signal Commands		
dem0pctma	dem100pctma	demlos
demlosgtp	trimdem4ma	trimdem20ma

Demand Characterizer Commands		
charclear	charlist	charset
demfunc		

Feedback Signal Commands		
fdbk0pctma	fdbk100pctma	fdbkfunc
trimfdbk4ma	trimfdbk20ma	iomode
ledconfig		

Output Shaft Position Sensing Commands

Command	Description	Argument <i>n</i> and Information
cpsvat0pct <i>n</i>	Sets/displays the DCM voltage used to determine 0% position. For the Group 57, the magnetic vector sensor reading is converted to a voltage scaled from 1 volt to 5 volts over the available travel span. The cpsvat0pct value sets the voltage that will be considered the 0% start point. Typically, this setting does not need to be changed.	<i>n</i> = desired voltage as a decimal (carried out to 3 decimal places).
travel <i>n</i>	Sets/displays the number of degrees that represents 100% travel. This command does not shift the 0% position; when increasing travel from a reduced travel setting, the 0% position may need to be changed first to keep travel within acceptable end points. The end points are defined by the CPS-5 voltage range.	<i>n</i> = desired length of travel in degrees. This value cannot exceed the maximum output shaft rotation of the actuator.
magcntsatposa <i>n</i>	The magnetic vector sensor counts near the mechanical stop. This represents the sensor reading at the lowest available point of travel. Sensor readings are translated to a standard CPS Voltage. The CPS Volts at Zero% represent the calibration setting for the lowest operating point of travel. The lowest available point of travel is the CCW position for the Group 57. This is normally set by the factory based on the type of actuator and is not changed in most applications.	<i>n</i> = The magnetic vector sensor counts near the mechanical stop as displayed using the posism Serial command.
magcntsatposb <i>n</i>	The magnetic vector sensor counts near the mechanical stop. This represents the sensor reading at the highest available point of travel. The highest available point of travel is the CW position for the Group 57. This is normally set by the factory based on the type of actuator and is not changed in most applications.	<i>n</i> = The magnetic vector sensor counts near the mechanical stop as displayed using the posism Serial command.

APPENDIX Serial Commands

General Configuration Commands

Command	Description	Argument <i>n</i> and Information
alarmout <i>n</i>	Sets/displays the polarity of the alarm output solid state relay.	<i>n</i> = "0": open on Alarm <i>n</i> = "1": closed on Alarm Upon loss of power, the relay is open regardless of the setting.
alarmoutmask <i>n</i>	Sets/displays (in hexadecimal format) which conditions will cause an alarm (see the "Alarm Mask and Polarity Setup Section", page 24, for details).	<i>n</i> = "0x0": no listed condition causes a status alarm <i>n</i> = "0xffffffff": all listed conditions cause a status alarm <i>n</i> = hexadecimal value for specific condition(s) which will cause an alarm. Multiple conditions may be selected by performing a hexadecimal addition of the condition values; e.g., Stall Condition and Torque Stop alarms -- hex 0x04 + 0x08 = 0x0C.
configformodel <i>n</i>	Sets certain DCM default values based on the actuator Serial number. These values are direction rotation for an increasing CPS-5 signal, expected range of CPS-5 signal, and the maximum travel.	<i>n</i> = "1": executes command
drvdir <i>n</i>	Sets/displays the actuator output shaft rotation direction resulting from an increasing Demand signal.	<i>n</i> = "0": CW rotation <i>n</i> = "1": CCW rotation
limitalarm <i>n</i>	Sets/displays alarm action if the actuator travels outside of the electronic limits and contacts an over-travel limit switch.	<i>n</i> = "0": mute (no alarm) <i>n</i> = "1": always
opmode <i>n</i>	Sets/displays the mode that controls the Demand signal source. This mode selects analog or digital control.	<i>n</i> = "0": analog Demand <i>n</i> = "1": digital Demand <i>n</i> = "2": run CW <i>n</i> = "3": run CCW <i>n</i> = "4": stay <i>n</i> = "5": stop
restoremodes <i>n</i>	Returns DCM settings to original factory configuration.	<i>n</i> = "1": executes command
sernum <i>n</i>	Sets the actuator Serial number.	<i>n</i> = Serial number
stallprot <i>n</i>	Sets/displays stall protection state.	<i>n</i> = "0": disabled <i>n</i> = "1": enabled
stalltime <i>n</i>	Sets/displays time the actuator runs in one direction before stall alarm is activated.	<i>n</i> = seconds: acceptable range is 30–450 seconds.
stepsize <i>n</i> %	Sets/displays the size of one incremental movement of the output shaft.	<i>n</i> = % of travel desired: acceptable range is 0.10%–2.5%. Include the "%" symbol after the number, otherwise the unit of measure will be degrees.
drvtiming <i>n</i>	Sets/displays the time required for the actuator to travel (90°) between the limits.	<i>n</i> = seconds. Acceptable range is: 9–150 (model 57-109) 20–400 (model 57-209)

General Configuration Commands

Command	Description	Argument <i>n</i> and Information
relayconfig <i>n1 n2 n3</i>	Configure a programmable output relay. Only one relay can be configured in a single command. Relays can be configured as either alarm relays or soft auxiliaries (See "CONFIGURING PROGRAMMABLE OUTPUT RELAYS", page 24).	<p><i>n1</i> = relay number: "1" selects the first programmable relay and "2" selects the second programmable relay.</p> <p><i>n2</i> = relay mode: greater-than (">") or less-than ("<") characters selects Soft Auxiliary Switch Mode. "0" or "1" selects alarm relay mode with alarm polarity that matches the function of the "alarmout" Serial command.</p> <p><i>n3</i> = operating value: For Soft Auxiliary Switch Mode <i>n3</i> is the position percent of travel relay trip point. For alarm relay mode, <i>n3</i> is the alarm mask which is the same format as used with the "alarmoutmask" Serial command.</p>

Torque Sensing Commands

Command	Description	Argument <i>n</i> and Information
ovtstop <i>n</i>	Sets/displays whether motor power will be removed during severe overtorque conditions. Torque sensing must be installed and enabled.	<p><i>n</i> = "0": disabled</p> <p><i>n</i> = "1": enabled</p>
ovtstoplevel <i>n</i>	Sets/displays the torque magnitude associated with severe output shaft torque conditions.	<i>n</i> = allowable torque magnitude (without stopping motor) in percent of actuator rating. May be set from 25% to 115% (factory set to 115%).
torq	Displays the torque on the output shaft measurement as a percentage of actuator rating. Also displays related values such as torq0k and torqconst.	No argument.
torq0k <i>n</i>	Sets/displays the value of DCM internal measurement corresponding to 0% torque on the output shaft.	<i>n</i> = the zero torque value in counts (noted on label inside DCM cover).
torq0pct <i>n</i>	This is an alternate method for setting torq0k, and is useful when the correct torq0k value is not already known. To use this command, remove all load from the output shaft, then execute torq0pct with argument "0" to let the DCM know that the torque sensing should be reading 0%.	<i>n</i> = "0"
torqalarm <i>n</i>	Sets and/or displays the torque magnitude associated with the first level of alarm.	<i>n</i> = allowable torque magnitude without alarm, in percent of actuator rating.
torqconst <i>n</i>	Sets/displays the value of DCM internal measurement corresponding to the torque span (the measurement at 100% minus the measurement at 0%).	<i>n</i> = the torque span value in counts (noted on label inside DCM cover).
torqenable <i>n</i>	Sets/displays the status of torque sensing.	<i>n</i> = "0": disabled; <i>n</i> = "1": enabled
torqprof	Displays a three table column: 1. Maximum travel divided into 10 segments 2. peak torque measured in each segment with motor running CW 3. peak torque measured in each segment with motor running CCW	No argument.

APPENDIX Serial Commands

Communications Configuration Commands

Command	Description	Argument <i>n</i> and Information
network <i>n</i>	Sets/displays the network to be utilized.	<i>n</i> = "0": HART/Analog <i>n</i> = "4": Modbus
harttype <i>n</i>	Sets/displays the DCM HART DD (Device Description). "239" is the proper DD; other DDs are for temporary use if the new DD is not available.	<i>n</i> = "1": ESR-D <i>n</i> = "10": Beck DCM <i>n</i> = "239": Beck MK2
polladdr <i>n</i>	Sets/displays the polling address used by HART to find individual devices if the HART bus has more than one device.	<i>n</i> = the polling address (a number between "0" and "15"). Unless multiple HART devices are connected in parallel on a single bus, the polling address should be set to "0".
modbaud <i>n</i>	Sets/displays the Modbus data rate.	<i>n</i> = "0": 300; <i>n</i> = "1": 600; <i>n</i> = "2": 1200; <i>n</i> = "3": 2400; <i>n</i> = "4": 4800; <i>n</i> = "5": 9600; <i>n</i> = "6": 19200; <i>n</i> = "7": 38400
modpolladdr <i>n</i>	Sets/displays the Modbus interface polling address.	<i>n</i> = a value between "1" and "247"
modparity <i>n</i>	Sets/displays the means of error checking individual Modbus characters. The actuator must be set to the same parity format as the control system.	<i>n</i> = "0": Even parity/One Stop Bit <i>n</i> = "1": Odd parity/One Stop Bit <i>n</i> = "2": NO parity/Two Stop Bits <i>n</i> = "3": NO parity/One Stop Bit

Diagnostic and Information Commands

Command	Description	Argument <i>n</i> and Information
demsorce	Provides a readout of information regarding the Demand on the actuator including the source of the Demand signal (Handswitch, demlos or Analog I/P), mode (follow, hold, CW, CCW, Stay or Stop), currently applied Demand signal as a %, the Demand function (linear, square root, square, or special), and the Demand out as a % (dem out shows the signal adjusted when using a non-linear Demand function (demfunc command)).	No Argument
help <i>n</i>	Displays help text for a specific command or lists all available Serial commands.	<i>n</i> = command name <i>n</i> = "all"
ledtest <i>n</i>	Tests the functionality of the DCM LEDs individually or as a group. If "all" is selected, the command will consecutively cycle through each LED twice. If an individual LED is selected, it will flash 12 times.	<i>n</i> = "1": DEMAND <i>n</i> = "2": POSITION <i>n</i> = "3": TRQ/THRUST <i>n</i> = "4": STALL <i>n</i> = "5": TEMP °F <i>n</i> = "6": FB OPEN <i>n</i> = "7": STOP/LIMIT <i>n</i> = "8": ACKNOWLEDGE <i>n</i> = "100": FWD <i>n</i> = "101": REV <i>n</i> = "102": STAT <i>n</i> = "All"
reset <i>n</i>	Performs the same reset sequence as when power is removed and reapplied.	<i>n</i> = "1": must equal "1" for command to execute.
signals	Displays the present DCM readings of four signals: Position signal from CPS-5 Demand Feedback Torque	No argument = signal readings are displayed. <i>n</i> = "all": an extended set of data is displayed.

Diagnostic and Information Commands

Command	Description	Argument <i>n</i> and Information
stat	Displays information on the status of the actuator, including: Time / Date, Demand, Position, Error (Demand minus Position), Step size, Dead band, Motor Status, Motor Run Time, Line Frequency, Motor Starts, Motor Reversals/Stalls, Number of Overtorque conditions, Positive & Negative Peak Torque (%), CW and CCW Inhibitor Status, Alarms	No argument
temperature <i>n</i>	Displays three values describing the ambient temperature in the actuator. Low extreme, present, high extreme. Can also change the temperature units.	No argument = temperatures are displayed. <i>n</i> = "F": changes units to Fahrenheit <i>n</i> = "C": changes units to Celsius
un stall	Resets the Stall Protection alarm to restore power to the motor. If the motor is still physically stalled, the Stall Protection alarm will recur.	No argument.
posism	Displays the magnetic field vector angle register value and associated diagnostic information. The first number reported reads zero when the cable is disconnected, otherwise it reads 128 with the cable properly connected. The second number is the magnetic vector angle register value. This number is used in conjunction with the "magcntsatposa" and "magcntsatposb" Serial commands.	No argument.

Demand Signal Commands

Command	Description	Argument <i>n</i> and Information
dem0pctma <i>n</i>	Sets/displays the Demand signal value that corresponds to 0% actuator position.	<i>n</i> = Demand signal as a decimal in mA. Minimum value is 0.50; maximum value is 100% Demand less 4.00 mA (e.g., if 100% Demand is 20.00 mA, the 0% value must be set for 16.00 mA or less).
dem100pctma <i>n</i>	Sets/displays the Demand signal value that corresponds to 100% actuator position.	<i>n</i> = Demand signal as a decimal in mA. Minimum value is 0% Demand plus 4.00 mA (e.g., if 0% Demand is 4.00 mA, the 100% value must be set for 8.00 mA or greater). Maximum value is 21.00 mA.
demlos <i>n</i>	Sets/displays the Demand signal threshold, below which the DCM recognizes the signal has been lost. The threshold is entered as a value in mA. This command also sets/displays the action initiated by the actuator during LOS (Loss Of Signal). LOS action options are "sip" (stay in place) or "gtp" (go to position). Demlos always reports both settings, but only sets one argument at a time. Demlos must be used twice to set both the threshold and action.	<i>n</i> = Demand signal in mA below which LOS occurs (e.g., the typical value for a 4–20 mA system is 3.20). -OR- <i>n</i> = "sip", "gtp" or "pat". The "pat" argument acts the same as "sip", but also suppresses the alarm--this is used in some pulsed applications.

APPENDIX Serial Commands

Demand Signal Commands

Command	Description	Argument <i>n</i> and Information
demosgtp <i>n</i>	Sets/displays the position to which the actuator will run upon loss of the Demand signal (LOS). This command has no effect if the actuator is set to "sip" (stay in place).	<i>n</i> = desired position of actuator expressed as a percentage of actuator travel in decimal form (e.g., 50% = 50.00).
trimdem4ma 4	Trims the Demand analog-to-digital sensing circuit to be accurate at 4 mA. This command should only be used when the Demand signal at the actuator is exactly 4.0 mA. Trim is factory set and should not normally require recalibration.	" 4 " is the only acceptable value; this trim can only be performed at 4 mA.
trimdem20ma 20	Trims the Demand analog-to-digital sensing circuit to be accurate at 20 mA. This command should only be used when the Demand signal at the actuator is exactly 20.0 mA. Trim is factory set and should not normally require recalibration.	" 20 " is the only acceptable value; this trim can only be performed at 20 mA.

Demand Characterizer Commands

Command	Description	Argument <i>n</i> and Information
charclear <i>n</i>	Clears a preconfigured Demand characterizer curve node by setting it to "unused". Any node numerically higher will be set to "unused" also.	<i>n</i> = node number: between 1 and 21.
charlist <i>n</i>	Displays the X-values and Y-values of Demand characterizer curve node(s).	<i>n</i> = node number: between 1 and 21. <i>n</i> = "all": displays all nodes
charset <i>n1, n2, n3</i>	Sets the X-values and Y-values of a specific node of the characterizer curve. The three arguments must be separated by commas.	<i>n1, n2, n3</i> = (<i>n1</i> is node number to modify, <i>n2</i> is X-value as a percentage, <i>n3</i> is Y-value as a percentage)
demfunc <i>n</i>	Sets/displays the Demand signal characterization function.	<i>n</i> = "0": linear <i>n</i> = "1": square root <i>n</i> = "4": special curve <i>n</i> = "5": square

Feedback Signal Commands

Command	Description	Argument <i>n</i> and Information
fdbk0pctma <i>n</i>	Sets/displays the mA value of the Feedback signal that represents the 0% output shaft position.	<i>n</i> = desired Feedback signal in mA at 0% output shaft position. Minimum value is 3.00 mA and the maximum must be at least 4.00 mA less than the Feedback signal value for the 100% output shaft position.
fdbk100pctma <i>n</i>	Sets/displays the mA value of the Feedback signal that represents the 100% output shaft position.	<i>n</i> = desired Feedback signal in mA at 100% output shaft position. Minimum value must be at least 4.00 mA greater than the Feedback signal value for the 0% output shaft position. Maximum value is 21.00 mA.
fdbkfunc <i>n</i>	Sets/displays the curve used to calculate the Feedback signal.	<i>n</i> = "0": linear <i>n</i> = "1": inverse Demand (curve enabled)

Feedback Signal Commands

Command	Description	Argument <i>n</i> and Information
trimfdbk4mA <i>n</i>	Trims the Feedback signal at 4 mA. Calibrated at the factory, should not normally require calibration.	<i>n</i> = present Feedback signal from the DCM in mA.
trimfdbk20mA <i>n</i>	Trims the Feedback signal at 20 mA. Calibrated at the factory, should not normally require calibration.	<i>n</i> = present Feedback signal from the DCM in mA.
iomode <i>n</i>	Sets/displays the function of a DCM connector pin. May be enabled for Feedback or potentiometer.	<i>n</i> = "0": none <i>n</i> = "1": Feedback enabled <i>n</i> = "2": potentiometer power enabled.
ledconfig <i>n1 n2</i> *	Changes the point within the position of travel that causes the red or green LEDs to light. May be used to turn the yellow LED on or off, swap the LED end point assignments or to individually turn off each LED. May also be used to turn off all of the LEDs at once.	<p><i>n1</i> = "red": sets the red LED to the <i>n2</i> argument.</p> <p><i>n1</i> = "green": sets the green LED to the <i>n2</i> argument.</p> <p><i>n2</i> = argument defining position of travel at which the selected LED (<i>n1</i>) will light. Accepts any number representing a valid percentage of travel position. <u>or</u></p> <p><i>n2</i> = "off": turns off the LED defined in <i>n1</i>.</p> <p>-----</p> <p><i>n1</i> = "yellow": sets the yellow LED to the <i>n2</i> argument.</p> <p><i>n2</i> = "off" or "on": turns off or on the yellow LED.</p> <p>-----</p> <p><i>n1</i> = "noninverted": Position <green turns on green; position >red turns on red.</p> <p>-----</p> <p><i>n1</i> = "inverted": Position <red turns on red; position >green turns on green.</p> <p>-----</p> <p><i>n1</i> = "defaults": Loads the default LED configuration, which is "noninverted" mode (green = 1%, red = 99%).</p> <p>-----</p> <p><i>n1</i> = "disable": all LEDs (red, green, yellow) are turned off.</p> <p>-----</p>

NOTE: In the event of a red/green position overlap, the red LED will be turned on. Error checking in the Serial command was added to help eliminate this possibility. In the case that only a single red or green position is defined, the yellow LED automatically remains off.

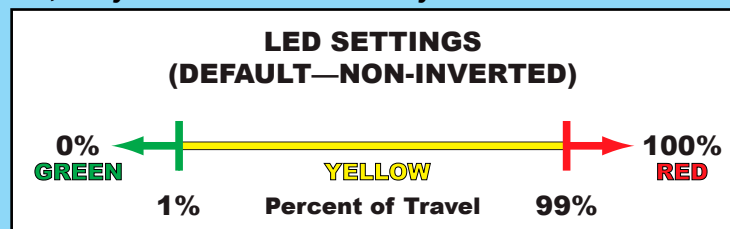

APPENDIX Serial Commands

BPU Command

Command	1st Argument	2ndArgument	Description
BPU <i>n1 n2</i>	4		Stay-In-Place: Sets the BPU Operation mode so that on Loss of Power, the LOP Alarm is asserted and the actuator will stay in place.
	3	[Position as a percentage of actuator travel in decimal form; e.g., 50% = "50.00"]	Sets the BPU Operation mode so that on Loss of Power, the LOP Alarm is asserted and the actuator will go to the position supplied in the 2nd Argument.
	2		Maintain Control: Sets the BPU Operation mode so that on Loss of Power, the LOP Alarm is asserted while the actuator continues to respond to the control system.
	1		Maintain Control/Mute Alarm: Sets the BPU Operation mode so that on Loss of Power, the actuator continues to respond to the control system. The LOP alarm is not activated.
	0		BPU is not installed. All BPU commands will be ignored.
	CPSFAIL	SIP	Sets the BPU mode with a failed position sensor such that the LOP Alarm is asserted and the actuator will stay in place.
	CPSFAIL	RUNCW	Sets the BPU mode with a failed position sensor such that the LOP Alarm is asserted and the actuator will run in the Clockwise direction until it hits the limit switch.
	CPSFAIL	RUNCCW	Sets the BPU mode with a failed position sensor such that the LOP Alarm is asserted and the actuator will run in the Counterclockwise direction until it hits the limit switch.
	ALARMVOLTS	[Volts]	The input voltage level at which the Loss of Power alarm will activate after the alarm delay period. The default value is 18.0V.
	ALARMDELAY	[Seconds]	The delay (in seconds) before the Loss of Power action and alarm will initiate after the main supply voltage falls below the alarm voltage threshold. Acceptable delay range is 0.0 to 25.5 seconds. The default value is 0.3 seconds.

NOTE: "ALARMDELAY" sets the delay for the BPU response, also.

APPENDIX *Optional Backup Power Unit*

DESCRIPTION OF THE OPTIONAL BACKUP POWER UNIT (BPU)



WARNING

When power is lost, the actuator may suddenly move position.

The optional BPU stores energy through the use of supercapacitors and is able to operate the actuator by moving to any position after a total loss of power. A fully charged BPU is capable of energizing the actuator for up to five full strokes running with seven seconds timing at rated load.

The BPU consists of a single Printed Circuit Board (PCB) containing the energy storage components as well as the charge management circuitry and DCM power inverter. The BPU is mounted directly to the DCM inside the Group 57 enclosure (see next page).

There are four available operation modes:

OPTION	OPTION NAME	DESCRIPTION
BPU Mode One	Maintain Control/Mute Alarm	Upon Loss of Power, the BPU provides bumpless power backup. The actuator will follow the control input and will NOT activate the power failure alarm. All other modes WILL activate the power failure alarm.
BPU Mode Two*	Maintain Control (Default)	Upon Loss of Power, the BPU provides bumpless power backup. The actuator will follow the control input.
BPU Mode Three	Go To Position	Upon Loss of Power, the BPU signals the DCM to initiate an automatic Loss of Power movement. The actuator will ignore the control input and will move to a preprogrammed position.
BPU Mode Four	Stay in Place	Upon Loss of Power, the BPU signals the DCM to stop. The actuator will ignore the control input and will stop at the position where the power failure occurred.

* Default mode

The BPU Mode can be changed using Modbus (see registers 40304 through 40306 on page 112) or by using the BPU serial command (see page 72).

The position to which the actuator travels in "Go To Position" mode is also programmable using Modbus (see registers 40305 and 40306 on page 113) or by using the BPU serial command (see page 72).

Regardless of the mode selected, the BPU will instantly return to normal service when power is restored.

The following BPU options are configurable using BPU serial commands (page 72) or Modbus (page 112):

- Programmable BPU actions with a failed position sensor.
- Voltage threshold adjustment.
- Loss of Power action delay.

VOLTAGE AND TIMING OPTIONS

To avoid false power failure alarms, the DCM uses a programmable alarm voltage level and delay timer to ignore intermittent power glitches. The factory default of these programmable values are optimized for both Vac and 24 Vdc versions of the Group 57:

- Alarm Voltage Threshold: 18 Vdc
- Alarm Delay Time: 300ms

Because of the DCM input selection circuitry, power glitches are bumpless events, with the DCM automatically switching between input and BPU power. The DCM will not signal a power failure alarm for a dropout that is less than the alarm delay.

While the alarm delay function can reduce nuisance power failure alarms, the trade off is a corresponding delay before the control system can respond to the event.

APPENDIX *Optional Backup Power Unit*

POSITION SENSOR FAILURE MODE OPTIONS

There is an additional configuration option to handle a power loss event during the unlikely occurrence of a position sensor failure. Operating without a position sensor is “open loop” with the termination of any movement controlled by the actuator limit switches.

The position sensor failure mode options are:

OPTION	DESCRIPTION
RUNCW	If the position sensor is not functioning, upon Loss of Power, the actuator will run in the clockwise direction until it hits the limit switch.
RUNCCW	If the position sensor is not functioning, upon Loss of Power, the actuator will run in the counterclockwise direction until it hits the limit switch.
SIP (Default)*	If the position sensor is not functioning, upon Loss of Power, the actuator will maintain its position.

* Default mode



Supercapacitors (4)

Mounting Screws (6)

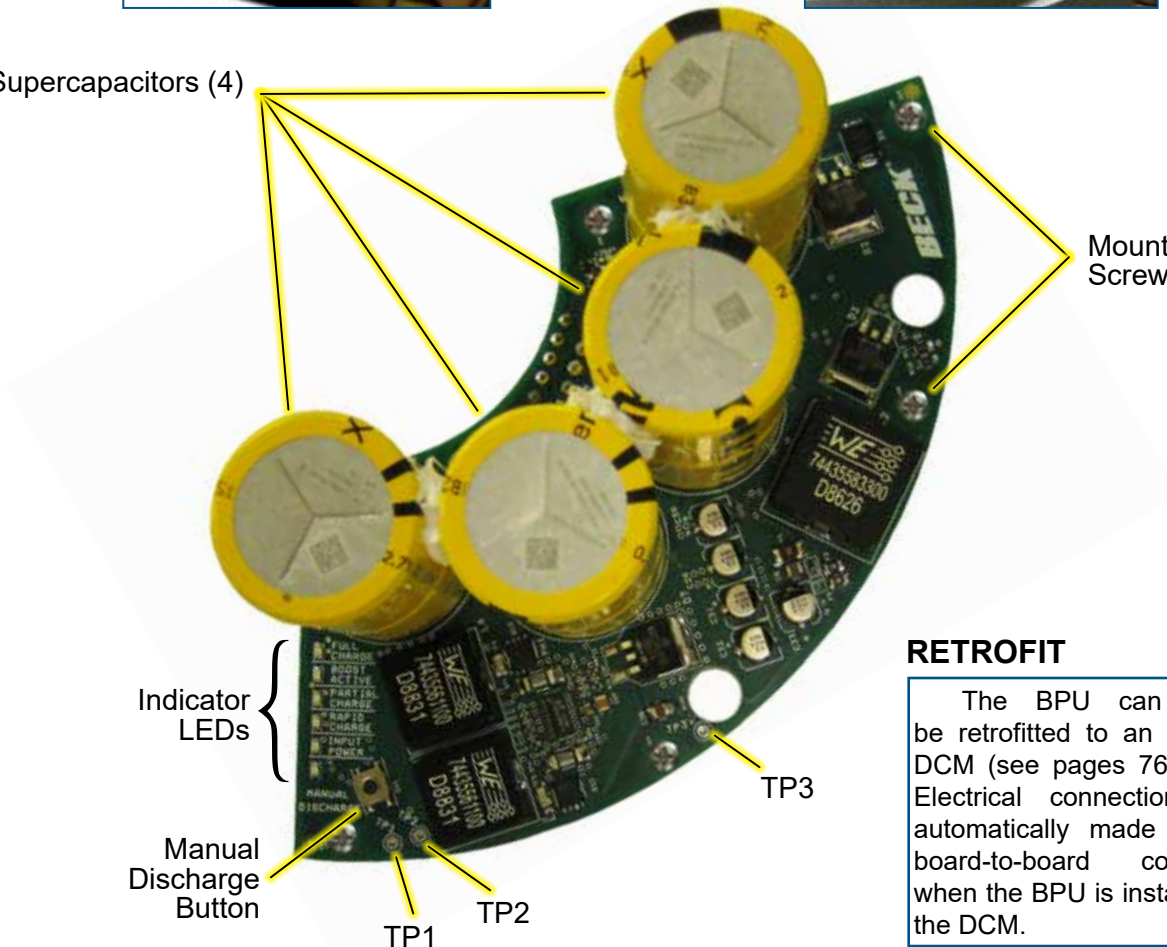

RETROFIT

The BPU can easily be retrofitted to an existing DCM (see pages 76 & 77). Electrical connections are automatically made with a board-to-board connector when the BPU is installed on the DCM.

Indicator LEDs

The function of each indicator is described in the following table (for location, see page 74):

INDICATOR	DESCRIPTION
INPUT POWER	When lit, indicates there is power at the input of the BPU charging circuit. This LED does not designate high or low voltage, but simply that some voltage is present.
RAPID CHARGE	When lit, indicates that the capacitors are charging as fast as the charge circuit allows (6.3A or more).
PARTIAL CHARGE	When lit, indicates there is more than 2 Vdc total charge on the four capacitors. This voltage level is suggested by UL as the threshold for safety. Values less than 2 Vdc are considered safe under all conditions.
BOOST ACTIVE	Is illuminated whenever the voltage regulator on the output side of the capacitor or circuit is producing a higher voltage than the total voltage on the capacitor bank. In practice, this LED indicates that the output voltage regulator is functional and is ready to supply power to the actuator.
FULL CHARGE	When lit, indicates the capacitors have reached approximately their full rated voltage.
MANUAL DISCHARGE	Lights to indicate that a circuit has been activated to discharge the capacitor bank.

Manual Discharge Pushbutton and Indicator

Prior to servicing, all power to the actuator must be removed. In addition, the BPU must be fully discharged before installing or removing the unit. The Manual Discharge system provides a method to accomplish a full discharge within approximately 45 minutes. Without the Manual Discharge function, it would take many hours for the BPU to fully discharge on its own.

With the input power to the actuator turned off, press the MANUAL DISCHARGE button (for location, see page 74). The MANUAL DISCHARGE Indicator will light when the button is pressed. The MANUAL DISCHARGE function will then shut down the output voltage to the DCM and motor.

In the event input power to the actuator is restored when the MANUAL DISCHARGE function is active, the BPU will automatically exit from the MANUAL DISCHARGE mode and begin charging.

Pressing the MANUAL DISCHARGE button while input power to the actuator is on has no effect.

Test Points

The following table describes each of the three BPU test points (for location, see page 74):

TEST POINT	DESCRIPTION	VOLTAGE RANGE
TP1	Common connection for measuring TP2 or TP3 voltage.	N/A
TP2	Supercapacitor positive bus.	With the BPU fully charged, the voltage should be ~10 Vdc. Completely discharged, the voltage should be 0 Vdc. The nominal minimum useful voltage is ~5 Vdc.
TP3	Output voltage from the BPU used to power the actuator.	If TP2 is greater than 5 Vdc, the voltage at TP3 should be 17.5 Vdc.

APPENDIX *Optional Backup Power Unit*

BPU CHARGING AND SUPERCAPACITORS

The Backup Power Unit (BPU) stores energy in supercapacitors and can use this energy as a short-term actuator power supply in the event of an input power failure.

To manage power into and out of the supercapacitors, there is a charging circuit to charge the capacitors from the power supplied to the actuator, and a voltage regulation circuit to correct the voltage to the Control Board as energy is withdrawn from the capacitors. This regulator boosts the capacitor voltage to a level of 17.5 Vdc. The general intention is that the input voltage being supplied to the actuator is higher than the regulated voltage from the supercapacitors. Specifically, input voltage to the actuator must be above the 17.5 Vdc level for the BPU to charge.

The input voltage to the actuator is needed to run the actuator motor and charge the BPU. The priority between these two functions is:

First Priority: Supply power to run the actuator motor per the input control signal to maintain control at all times. While the motor is active, the BPU is in slow charge mode.

Second Priority: Supply power to fast charge the BPU energy storage components to attain a full charge as soon as possible (when the motor is stopped).

Third Priority: Once a full charge is attained, slow charge the energy storage components to maintain the charge level.

BPU RETROFIT / INSTALLATION INSTRUCTIONS



WARNING

Electrical shock hazard and risk of ignition of hazardous atmospheres. Disconnect actuator power before installing or removing. Do not remove the top cover in a hazardous atmosphere. Fully discharge the BPU by depressing the Manual Discharge button and waiting until ALL indicators are off.



CAUTION

Static sensitive device. Handle only using ESD protection practices in a static safe environment.



CAUTION

Reinstall covers immediately after installation or service to prevent moisture or other foreign matter from entering the actuator.

When ordered separately, the BPU assembly (Beck P/N 22-5015-26) includes six hex standoffs as well as the BPU circuit board (Beck P/N 22-4015-26). The steps to install the BPU are detailed below:

- After removing the top cover (see page 21), replace the (6) 6-32 cross recessed pan head screws with the hex standoffs in the locations shown below. Tighten the standoffs to 5 lb-in (.6 N•m).



- Install the BPU so that it mates with the corresponding connector on the DCM, as shown below.

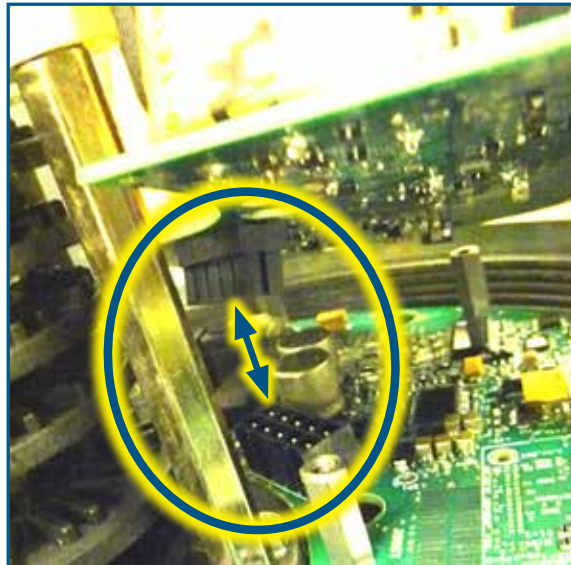

- Secure the BPU in place using the screws removed earlier. Tighten the (6) 6-32 cross recessed pan head mounting screws to 5 lb-in (.6 N•m).
- Replace the top cover (see page 21).

APPENDIX *Optional Backup Power Unit*

BPU MAINTENANCE

ENERGY STORAGE COMPONENT INFORMATION

Supercapacitors have a typical maximum temperature rating of 65°C. (149°F.) and a qualified maximum temperature rating of 85°C. (185°F.). The BPU complies with the circumstances for 85°C. (185°F.) operation; however, the life expectancy of the BPU is reduced as the temperature increases.

The published typical lifespan of the supercapacitors (as provided by the manufacturer) are:

- 10 years at room temperature.
- 3 years at 30°C. (86°F.) ambient.
- 1,500 hours at 65°C. (149°F.) ambient.

PERIODIC VERIFICATION TEST

It is recommended that the BPU be tested during planned power outages at regular intervals to ensure that it functions according to the configured options. Regular planned power outage testing is a critical part of any power loss contingency program.

APPENDIX *Modbus RTU*

PRECAUTIONARY INFORMATION



WARNING

Repeated changes to actuator configuration parameters within a control algorithm may result in process instability and actuator damage.

NOTE: When network security is a concern, the actuator should be placed in write protect mode.

APPENDIX *Modbus Installation*

TERMINAL BLOCK ASSIGNMENTS

Terminal Block Assignments		
Terminal	Common Name	Modbus Name
33	Data+	D1
32	Data-	D0
34	Common	Common

RECOMMENDED CABLE

The following cable has been documented as meeting Modbus interface requirements:

- Belden 3106A
- Alpha Wire 6454

TERMINATION AND LINE POLARIZATION

For error-free data exchange, line termination and line polarization (as specified in the Modbus standard) are required. The rules of termination in the Modbus specification are:

- Line termination shall be placed at the two ends of the bus that are the greatest wire-length distance apart.
- Line polarization shall be provided at only one location on the bus, typically near the Modbus client.

Because Modbus RTU is a multi-drop network, there is no provision for built-in termination or line polarization in the actuator. When needed, termination hardware can be connected at the actuator terminal block.

Because line polarization is typically provided at the Modbus client, Beck Actuators do not provide bias voltage for this function. The diagram at right shows a typical termination and line polarization connection for a two actuator network.

APPENDIX Modbus Installation

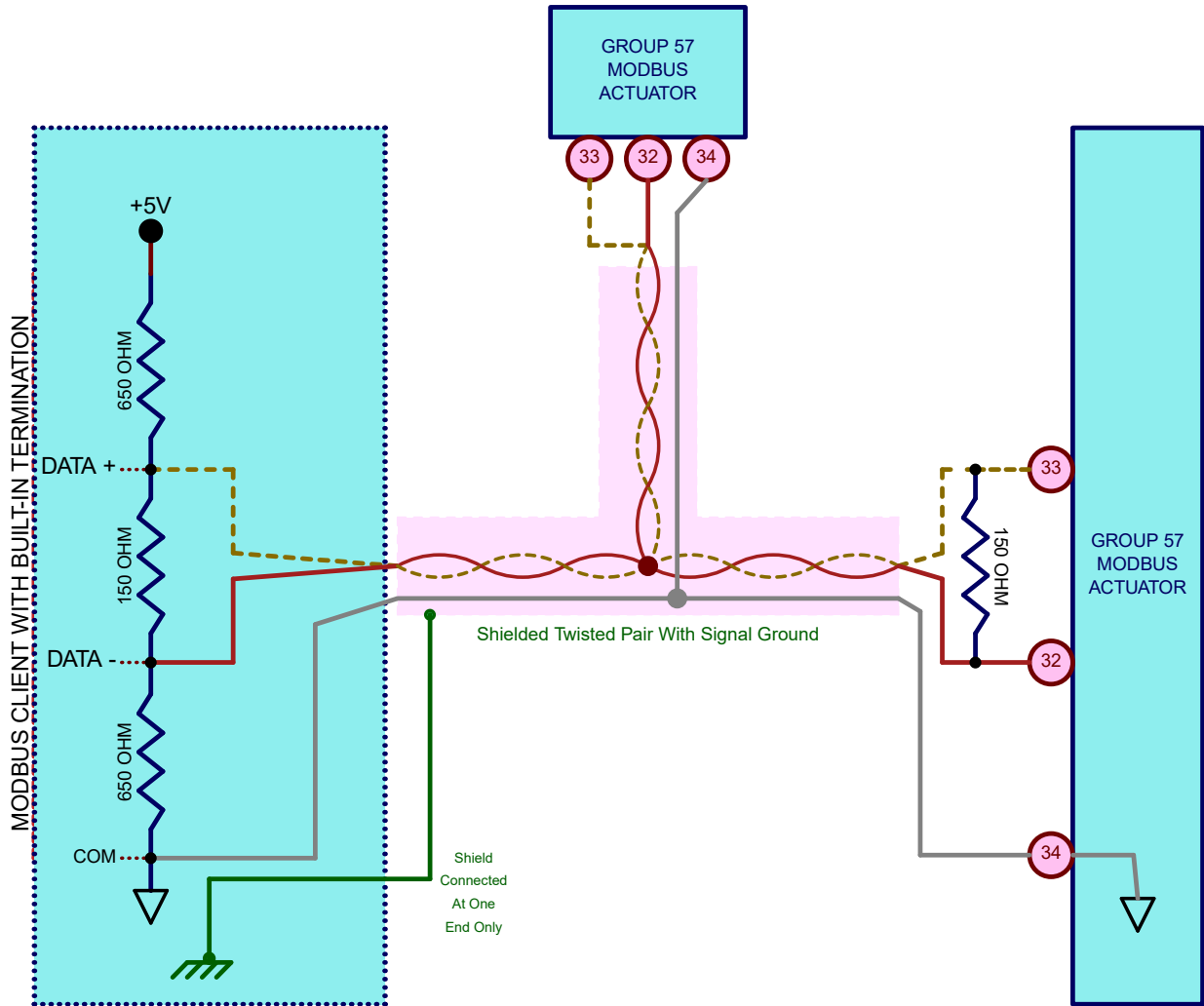

For control systems that do not provide for termination or line polarization, a separate device must be added to provide it. One such module is the Loytec LT-B4 (shown below).



Photo courtesy of Loytec

APPENDIX *Modbus Interface Setup*

MODBUS CONFIGURATION INTERFACES

The DCM-3 has three configuration interfaces available for Modbus setup: the Pushbuttons, the Modbus interface itself and the Serial port.

Pushbuttons

Two pushbutton combinations are available to reset the Modbus interface to standard and factory defaults (see the “Modbus Defaults Pushbutton Combinations” section).

Modbus Interface

It is possible to change the Modbus baudrate, parity and polling address via the Modbus interface itself using the following steps:

- If the baud rate, parity or polling address are not known, use the pushbuttons to set the DCM to known Modbus defaults.
- Establish Modbus communications to the DCM.
- Change the polling address to the desired value by writing to Register 40018.
- Reestablish communications at the new polling address.
- Change the parity to the desired value by writing to Register 40017.
- Reestablish communications with the new parity configuration.
- Change the Baudrate to the desired rate by writing to Register 40016.
- Reestablish communications at the new Baudrate.
- Once the basic communications settings have been updated, further modification to the DCM configuration is possible by changing any of the configuration holding registers listed in the “Holding Register Parameter Map”.

Serial Port



CAUTION

Changes made to the actuator through Serial communications may not necessarily be reflected in asset management systems. Be sure to verify any changes made Serially and make manual corrections to the asset management system if necessary.

The Serial port interface is accessible by connecting a computer to the DCM using the DB9 connector (See the “DCM Interfaces” Section). Basic Modbus Serial commands are listed in the “Communications Configuration Commands” table.

APPENDIX *Modbus Interface Setup*

MODBUS PHYSICAL INTERFACE

Modbus is a Serial digital interface that transmits information over a twisted pair of wires plus a common wire. The electrical interface for Modbus is a 5V level differential signal scheme called RS- 485 (or EIA-485). The Modbus terminology for this interface is Modbus “Two-wire” (2W-MODBUS).

BASIC MODBUS COMMUNICATIONS SETUP

Polling Address

Each actuator on the Modbus network must be assigned a unique polling address. This address is a number that ranges from 1 to 247. There are two ways to configure the polling address:

- Using the Serial command “modpolladdr”.
- Using the Modbus address holding register: *40018*.

Note that address 246 is the default and is normally reserved for commissioning.

Data Rate

The actuator must be set to the same data rate as the control system. Beck Modbus actuators support the following data rates: 300, 600, 1200, 2400, 4800, 9600, 19200 and 38400 bps. There are 2 ways to select the Modbus baudrate:

- Using the Serial command “modbaud” followed by the desired baudrate.
- Using the Modbus baudrate holding register *40016* with the following codes:

Code	Baudrate
0	300
1	600
2	1200
3	2400
4	4800
5	9600
6	19200
7	38400

Parity

Parity is used as a means of error checking individual Modbus characters. The actuator must be set to the same parity format as the control system.

EVEN, ODD or NO parity is available. Parity can be set through the “modparity” Serial command or the modbus parity register (40017). Both of these options use the following codes:

Code	Parity/Stop Bit
0	Even Parity/One Stop Bit
1	Odd Parity/One Stop Bit
2	NO Parity/Two Stop Bits
3	NO Parity/One Stop Bit

ADDITIONAL MODBUS SETUP SERIAL COMMANDS

In addition to the “modbaud”, “modparity” and “modpolladdr” commands described earlier, there are additional commands available to configure other aspects of the Modbus interface. These additional commands are:

MODENDIAN Command

This command sets byte order for modbus floating point and 32 bit register sets. More information is available in the “Modbus Message” section. The selection options are:

Command	Value
modendian 0	Big Endian
modendian 1	Middle-Little Endian
modendian 2	Little Endian
modendian 3	PDP Endian

MODSCALING Command

This command sets the scaling factors for scaled integers types. There are 6 options:

Command	Range	Limits
modscaling 0	0-10000 counts representing 0% to 100%	-500 (-5%) to 10500 (105%)
modscaling 1	0-1000 counts representing 0% to 100%	-50 (-5%) to 1050 (105%)
modscaling 2	0-100 counts representing 0% to 100%	-5 (-5%) to 105 (105%)
modscaling 3	0-255 counts representing 0% to 100%	-12 (-4.7%) to 267 (104.7%)
modscaling 4	0-4095 counts representing 0% to 100%	-204 (-4.98%) to 4299 (104.98%)
modscaling 5	0-65535 counts representing 0% to 100%	0 (0%) to 65535 (100% demand/position, 120% torque)

MODCONFIG Command

This command takes two arguments. The command modifies normal DCM Modbus behavior. The first argument controls whether Modbus client broadcast messages are ignored. The second argument controls whether the demand status value is forced to “good”. The demand status value is available for control systems that map control system Analog Output Function Blocks to Modbus. The MODCONFIG command fields are:

modconfig [Broadcast Override: 0=Ignore/1=Accept] [Demand Status: 0=Ignore/1=Active]

modconfig 0 0	Broadcast messages are ignored. Demand status ignored.
modconfig 0 1	Broadcast messages are ignored. Demand status value is active.
modconfig 1 0	Broadcast messages are accepted. Demand status ignored.
modconfig 1 1	Broadcast messages are accepted. Demand status value is active.

The default configuration is: **modconfig 1 0**.

Configuration Lockdown Serial Command (Write Protect)

When the DCM is placed in configuration lockdown, all attempts to change Modbus configuration parameters will be rejected. Modbus process parameters will still be writable.

The default state of configuration lockdown/write protection is OFF (i.e., writes are allowed).

Configuration lockdown/write protection can be switched on or off using the “wrprot” serial command:

- **wrprot 0**: writes are allowed
- **wrprot 1**: writes are blocked

Write protection can also be switched off using the eeprom_select parameter at Register 40074.

Since the Modbus protocol does not define a response code to denote write protect status, exception code 4 (server device failure) will be returned when write protect mode is active when an attempt to change a configuration parameter is made.

Network Configuration Serial Command

The Beck DCM has built-in support for multiple communication protocols. In most cases, a DCM will be set at the factory to operate as a Modbus server; however, in some cases when the DCM is setup from scratch, it is necessary to manually turn on the Modbus interface.

The basic Serial command for accomplishing this is the “network” command.

- **network 4**: (Modbus hardware active)

The “network 4” setting is required for normal Modbus operation. There is no Modbus access available for this function.

APPENDIX Modbus Operation

Modbus Default Settings

Factory and Standard Defaults

When a Modbus actuator ships from the factory, the Modbus interface will be configured to match customer requirements for baudrate, parity and server address. These customer-supplied defaults are stored in the DCM as *factory defaults*.

In the absence of a customer directive, *standard defaults* are stored. Standard Default settings are the same for all DCMs. They are:

- Server Address: The standard default server address is **246**.
- Baud Rate: The standard default baud rate is **19200**.
- Parity: The standard default parity is **EVEN**.

Modbus Defaults Pushbutton Combinations

Because access to the Serial command port is not always available, the DCM pushbutton interface has been expanded to support resetting Modbus communication parameters to factory or standard default values.

Since analog demand is disabled when using the Modbus interface, the DCM pushbuttons related to analog demand have been re-purposed for this function.

Restore Standard Modbus Defaults Pushbutton Combination: Standard defaults will be restored with the following pushbutton combination:

[FACTORY] + [0% SET DEMAND]



Restore Factory Modbus Defaults Pushbutton Combination Factory defaults will be restored with the following pushbutton combination:

[FACTORY] + [100% SET DEMAND]



NETWORK ACTIVITY LED

The Modbus Network Activity LED is located on the DCM board, as shown below.



The Network Activity LED blinks only when a Modbus message addressed to the DCM with a proper CRC-16 value is received. Because Modbus clients have no specified polling or timeout intervals, the Network Activity LED will continue to blink for 15 seconds after the last valid message has been received.

MODBUS BINARY SIGNAL MAP

The majority of binary parameters are available individually as Discrete Inputs or as part of a bit array within an Input Register. The relationship between these two formats is described in the diagram on the next page (see page 91 for the availability notes).

Note that binary parameters represented by Discrete Inputs 10001 through 10032 (Input Registers 30041 and 30042) can be masked using the “alarmoutmask” Serial command.

APPENDIX Modbus Operation

GROUP 57 MODBUS BINARY SIGNAL MAP

(DCM-5 Rev. 3.62) Rev. 20201203

	Handswitch is in the AUTO position.		Discrete 10044	Register 30044-BIT 7
	Handswitch is in the CW position.		Discrete 10043	Register 30044-BIT 6
	Handswitch is in the CCW position.		Discrete 10042	Register 30044-BIT 5
	CW over-travel limit switch has been reached.		Discrete 10041	Register 30044-BIT 1
	CCW over-travel limit switch has been reached.		Discrete 10040	Register 30044-BIT 0
	Torque/Thrust out of accurate measurement range. (2)		Discrete 10038	Register 30043-BIT 11
	Ambient Temperature out of accurate measurement range.		Discrete 10037	Register 30043-BIT 10
	Demand out of accurate measurement range.		Discrete 10036	Register 30043-BIT 9
	Position sensor out of accurate measurement range.		Discrete 10035	Register 30043-BIT 8
	Analog Position feedback is overridden with a fixed value.		Discrete 10034	Register 30043-BIT 0
31	Eventlog Memory Self Test Failure.		Discrete 10032	Register 30042-BIT 15
30	Excessive Power Supply Ripple Detected.		Discrete 10031	Register 30042-BIT 14
29	Limit Switch sensing error.		Discrete 10030	Register 30042-BIT 13
28	Handswitch sensing error.		Discrete 10029	Register 30042-BIT 12
27	Analog Demand has been detected while under PAT Control.		Discrete 10028	Register 30042-BIT 11
26	Analog Demand has been detected while under HART/FF/Profibus/Modbus Control.		Discrete 10027	Register 30042-BIT 10
25	Invalid Discrete Input (Overrides) signal combination detected.		Discrete 10026	Register 30042-BIT 9
24	Serial Communications Hardware Failure.		Discrete 10025	Register 30042-BIT 8
23	Unused.		Discrete 10024	Register 30042-BIT 7
22	Unused.		Discrete 10023	Register 30042-BIT 6
21	Loss of Power (BPU Equipped Units Only). (2)		Discrete 10022	Register 30042-BIT 5
20	Handswitch Not In Auto.		Discrete 10021	Register 30042-BIT 4
19	DC bus not ready (G22: Possible lost Phase).		Discrete 10020	Register 30042-BIT 3
18	Unused.		Discrete 10019	Register 30042-BIT 2
17	Demand signal is over allowable limits.		Discrete 10018	Register 30042-BIT 1
16	Invalid DCM pushbutton combination detected.		Discrete 10017	Register 30042-BIT 0
15	Memory Self-Test Failure.		Discrete 10016	Register 30041-BIT 15
14	Temperature Sensor Hardware Failure.		Discrete 10015	Register 30041-BIT 14
13	Position Sensor Bad Communications or Cable Problem.		Discrete 10014	Register 30041-BIT 13
12	Internal DCM hardware problem (I2C Interface).		Discrete 10013	Register 30041-BIT 12
11	Demand A/D converter problem.		Discrete 10012	Register 30041-BIT 11
10	Position Sensor Hardware problem.		Discrete 10011	Register 30041-BIT 10
9	Torq/Thrust Hardware Failure: Bad sensor signal or A/D converter problem. (2)		Discrete 10010	Register 30041-BIT 9
8	RTC (timekeeping IC) Failure. Eventlog Information will not be reliable.		Discrete 10009	Register 30041-BIT 8
7	Position Sensor Out of Normal Range.		Discrete 10008	Register 30041-BIT 7
6	Temperature Out of Normal Range.		Discrete 10007	Register 30041-BIT 6
5	Feedback Loop is Open.		Discrete 10006	Register 30041-BIT 5
4	DC Volts Low.		Discrete 10005	Register 30041-BIT 4
3	Overtorque Stop. (2)		Discrete 10004	Register 30041-BIT 3
2	Stall Alarm.		Discrete 10003	Register 30041-BIT 2
1	Torq/Thrust High. (2)		Discrete 10002	Register 30041-BIT 1
0	Demand Loss of Signal.		Discrete 10001	Register 30041-BIT 0

Alarm Mask Bit

Note

Discretes

Input Registers

HANDSWITCH, LIMIT SWITCH AND OVERRIDE INPUTS CROSS REFERENCE

The state of the Handswitch, limit switch and override inputs are available in register and discrete input format.

Handswitch and limit switch values are mapped to Discrete Inputs 10040 to 10045 and Input Register 30044. Override inputs are only available at Input Register 30044. The relationship between these items is shown in the following diagram:

Modbus Handswitch, Limit Switch and Override Inputs BIT MAP

(DCM Rev 3.22 or later) TGB 20180731 Rev 1.0

Unused: Normally Reads zero.	15	Register 30044-BIT 15
Unused: Normally Reads zero.	14	Register 30044-BIT 14
Unused: Normally Reads zero.	13	Register 30044-BIT 13
Unused: Normally Reads zero.	12	Register 30044-BIT 12
Unused: Normally Reads zero.	11	Register 30044-BIT 11
Unused: Normally Reads zero.	10	Register 30044-BIT 10
Unused: Normally Reads zero.	9	Register 30044-BIT 9
Unused: Normally Reads zero.	8	Register 30044-BIT 8
AUTO Handswitch Position when true.	7	Register 30044-BIT 7
CW Handswitch Position when true.	6	Register 30044-BIT 6
CCW Handswitch Position when true.	5	Register 30044-BIT 5
STOP Override Input is active when true.	4	Register 30044-BIT 4
CW Override Input is active when true.	3	Register 30044-BIT 3
CCW Override Input is active when true.	2	Register 30044-BIT 2
CW Limit Switch is active when true.	1	Register 30044-BIT 1
CCW Limit Switch is active when true.	0	Register 30044-BIT 0
		Discrete 10044
		Discrete 10043
		Discrete 10042
		Discrete 10041
		Discrete 10040

APPENDIX *Modbus Operation*

MODSTAT Serial Command

The “MODSTAT” Serial command provides a snapshot on what the actuator will send for position and what it received for demand. “MODSTAT” also includes information on the Modbus interface configuration which can be read with a single command.

A typical “MODSTAT” command output is as follows:

```

*** Modbus Reporting for Present Position: [49.93]
Register 30002 [0x4247] (49.933)
Register 30001 [0xBBC1] (49.933)
Register 30008 [0x01f3] (Type 1: 0% = 0 span = 1000)
*** Modbus Reporting for Present Demand: [49.93]
Register 40002 [0x4247] (49.933)
Register 40001 [0xBBC1] (49.933)
Register 40007 [0x01f3] (Type 1: 0% = 0 span = 1000)
Modbus Demand Address: Latest-- | RECEIVED: [ 40007 ] |
Modbus Coils: NONE
Modbus Network Silent Seconds Count: [ 9 ]
Modbus Message Count: [ 6 ]
Modbus CRC Error Count: [ 0 ]
Modbus Exception Count: [ 0 ]
Baudrate: 19200
modparity [0-3]: [Code 0 = 8 Data/EVEN/1 Stop]
Modbus Polling Addr: [ 246 ]
Floating Point Format: [Endian 0: (ABCD translated to ABCD)]
Scaled Integer: Type 1 Configuration [(0%=0 CNTS) (SPAN=1000 CNTS)]
Poll Addr 0 Broadcast Messages are ACCEPTED.
Demand Status Ignored
OK

```

In this example, the actuator reports that there are no Modbus Coils that are active and that it has been 9 seconds since a Modbus message has been processed on the wire (Modbus Network Silent Seconds Count) and that there have been zero CRC and Exception errors.

Demand (Setpoint) Hierarchy

For Group 57 Beck Actuators, there is a fixed hierarchy of sources that determine the actual setpoint controlling the output shaft position. This hierarchy is:

- 1. Handswitch Setting.
- 2. Limit Switch Status.
- 3. Sensor Status.
- 4. Logic-Level Discrete Inputs.
- 5. Network (Modbus) Setpoint. Since the Modbus control interface has the capability of handling multiple setpoint formats and sources, an additional hierarchy is established to determine what the effective network setpoint will be. This network setpoint hierarchy is:
 - 5.1 The Actuator Stop Override Coil (00001).
 - 5.2 The Actuator 100% Demand Override Coil (00002) or the Actuator 0% Demand Override Coil (00003).
 - 5.3 The latest modulating setpoint in Scaled Integer (demand_scaled at Register 40007 or floating point registers 40001 and 40002).

The following table defines the relationship between the override coils and the setpoint holding registers:

Network Setpoint: Override Coil/Setpoint Holding Register Relationship				
Actuator Stop Override Coil	Actuator 0% Override Coil	Actuator 100% Override Coil	Condition	Outcome
1	X	X	Actuator Stop Override Coil is asserted	The actuator ceases all movement. All other network setpoint sources are ignored. The actuator Handswitch and logic level overrides can bypass this coil.
0	1	1	Illegal Override Coil Request	When both the 0% and 100% override coils are asserted, the Stop Override Coil is automatically asserted.
0	1	0	Actuator 0% Override Coil is asserted	The actuator moves to the 0% setpoint. With the exception of the Actuator Stop Override Coil, all other network setpoint sources are ignored. The actuator Handswitch and logic level overrides can bypass this coil.
0	0	1	Actuator 100% Override Coil is asserted	The actuator moves to the 100% setpoint. With the exception of the Actuator Stop Override Coil, all other network setpoint sources are ignored. The actuator Handswitch and logic level overrides can bypass this coil.
0	0	0	All Actuator Overrides are Inactive	The actuator will not move when the overrides become inactive, but will move to the next setpoint holding register value when it is received.

There are 2 methods of determining the active Network Setpoint:

- Modbus Demand Address Readback Registers 30076 and 30077.
- The “MODSTAT” Serial command.

APPENDIX *Modbus Operation*

Modbus Demand Address Readback Registers

To determine which network setpoint is controlling the actuator, two input registers are available to determine the active source:

- **Last Setpoint Address Received:** The Modbus Address of the last received setpoint (Input Register 30077).
- **Last Setpoint Address Accepted:** The last accepted setpoint (Input Register 30076).

For either Register (30077 or 30076), the value 0xFFFF (65535) indicates that no applicable demand address has been accessed.

For example, if the the stop coil was previously asserted after a setpoint has been received at Address 40007 these registers will report:

- Register 30076 (last accepted setpoint) will contain the decimal value of 00003 (since the stop coil outranks Register 40007).
- Register 30077 (last received setpoint) will contain a value of 40007 decimal (0x9C47).

Demand Setpoint Reading with “MODSTAT” Serial Command

The “MODSTAT” Serial command will display each demand source and which is controlling the actuator. In the previous example, the stop coil has been asserted and has blocked an incoming setpoint from Address 40007.

The active network demand source is described by the the line that begins “Modbus Demand Address.” It shows that latest demand address RECEIVED was 40007 while the present ACCEPTED address is 00003 (the stop coil):

```
-----
*** Modbus Reporting for Present Position: [49.94]
Register 30002 [0x4247] (49.935)
Register 30001 [0xBDE3] (49.935)
Register 30008 [0x01f3] (Type 1: 0% = 0 span = 1000)
*** Modbus Reporting for Present Demand: [49.93]
Register 40002 [0x4247] (49.933)
Register 40001 [0xBBC1] (49.933)
Register 40007 [0x01f3] (Type 1: 0% = 0 span = 1000)
Modbus Demand Address: Latest-- | RECEIVED: [ 40007 ] | ACCEPTED: [ 00003 ] |
Modbus Coils: StopCoil |
Modbus Network Silent Seconds Count: [ 9 ]
Modbus Message Count: [ 22 ]
Modbus CRC Error Count: [ 0 ]
Modbus Exception Count: [ 2 ]
Baudrate: 19200
modparity [0-3]: [Code 0 = 8 Data/EVEN/1 Stop]
Modbus Polling Addr: [ 246 ]
Floating Point Format: [Endian 0: (ABCD translated to ABCD)]
Scaled Integer: Type 1 Configuration [(0%=0 CNTS) (SPAN=1000 CNTS)]
Poll Addr 0 Broadcast Messages are ACCEPTED.
Demand Status Ignored
OK
-----
```

Process Variable Input Register Block

Key process variables in Scaled integer format can be retrieved in a single Function Code 4 transaction by reading input registers 30038 to 30041. This single FC04 command returns:

- 30038: Duplicate scaled position (mirrors register 30008)
- 30039: Duplicate scaled torque (mirrors register 30009)
- 30040: Duplicate scaled demand (mirrors register 40007)
- 30041: Alarm Bytes 1 and 0 (mirrors discrete inputs 10001 to 10016)
- 30042: Alarm Bytes 2 and 3 (mirrors discrete inputs 10017 to 10032)

APPENDIX *Modbus Troubleshooting*

Communications Failure Troubleshooting Checklist

The main symptom of a communications failure is when the Modbus controller is transmitting to the actuator, and the Network Activity LED is not blinking. Here are some suggestions to solve this problem:

- Check the communications link for shorts and opens.
- Verify that the terminal connections are correct: Modbus RTU is polarity sensitive. If the data lines are reversed, communications cannot occur. A signal ground connection is mandatory and must be connected to the proper terminal.
- Verify that line termination at both ends of the network is installed. Termination is installed between the DATA+ and DATA- lines. Paragraph 3.4.5 of the Modbus Serial specification suggests that either a 150 Ohm resistor or a 1nF Capacitor in series with a 120 Ohm resistor are appropriate terminations.
- Two Line polarization resistors should be installed at the Modbus controller. Paragraph 3.4.6 of the Modbus Serial specification recommends a value between 450 and 650 Ohms. A 650 Ohm value supports a greater number of devices on the segment.
- Use an appropriate tool such as an oscilloscope to verify correct signal levels at the actuator terminals. The differential voltage between DATA+ and DATA- should be between 1.5V and 6V. Long cable runs may require the use of a repeater.
- Verify that the Actuator baudrate, parity and polling address settings match the Modbus controller settings.
- Verify the actuator DCM is configured for Modbus using the “network” Serial command. The network setting must be four (network 4).
- Verify that the Modbus controller is transmitting frequently enough to the actuator to keep the Network Activity LED blinking. If the controller transmits a Modbus message at a rate of less than every 15 seconds, the Network Activity LED will stop blinking despite the fact that there is nothing wrong with the connection.

Communications Errors Troubleshooting Checklist

Diagnostics built into modern control systems are capable of reporting communications errors. Such errors include:

- Message Retries: More than one transmission of a particular request was required for a successful response from the actuator.
- Message Timeouts: A message request was abandoned because the actuator never responded.
- CRC Errors: A message from the actuator contained a CRC value that did not match the Modbus controller calculated value.

Many of the causes of communications failures can contribute to communications errors, so it is a good idea to verify the items in the previous checklist with the emphasis on confirming proper line termination, polarization, signal levels and link settings. Other possible communications error sources are:

- Verify that there is only one Modbus device for each polling address on each communications link. Actuators configured with duplicate polling addresses will interfere with each other.
- Verify that there are no additional line terminators installed other than the two connected at the far ends of the network. Adding a third line terminator may allow some devices to communicate and block others.
- Line polarization is important for error-free communications. A separately powered RS-485 polarization and termination module may be required for control systems with optically isolated RS-485 ports.
- For shielded cable, verify that the shield is connected on only one end to Earth. Connecting both ends can sometimes result in a circulating ground current that can interfere with communications.
- Verify that the parity setting on the actuator matches the setting on the Modbus controller.
- Long communication links can introduce sporadic errors. A repeater may be required to strengthen signal levels to eliminate the errors.

APPENDIX *Modbus Troubleshooting*

Communications Errors Troubleshooting Checklist (cont'd)

- Verify that there is only one active Modbus client of a given link at one time. Simultaneous client requests cause errors.
- Use of transmission cables not designed for RS-485 can be the cause of communications errors.
- Communication links that pass near sources of strong electromagnetic waves may be susceptible to communications errors. Relocate them to solve the problem.

Actuator Setpoint Troubleshooting Checklist

Once error-free communications have been established, there can still be issues in controlling the actuator. For example: A setpoint is transmitted to the actuator (e.g. via Register 40007) and the actuator transmits a correct Modbus response message but does not move to the new setpoint value. For this case, the following items should be verified:

- Verify that the Handswitch is in AUTO.
- Verify that the digital override signals are inactive.
- Verify that there are no issues with the actuator setup, such as a position sensor error.
- Verify that none of the Modbus coils is active (by checking the last accepted demand address listed with the MODSTAT Serial command or Input Register 30076). Note that all incoming setpoints will be ignored until Modbus coils are cleared.
- When using the Demand floating point register set (Registers 40001 and 40002), verify the endian format is correct and that the value is in the correct 0% to 100% range.
- When using the Demand scaled integer register (40007), verify the value being sent matches the expected limits configured in Register 40006 or the modscaling Serial command.

Actuator Configuration Troubleshooting Checklist

When configuring the actuator via Modbus, the actuator should be in a condition so that any control process will not be upset. If a particular configuration value is rejected by the actuator, the following items should be checked:

- Verify that the actuator is not in write protect mode. Write protect mode can be modified by using the “wrprot” Serial command or Holding Register 40074.
- Verify that the configuration value being written is legal. For example, writing a Modbus address of “400” to Holding Register 40018 will be rejected since Modbus addresses must be between 1 and 247.
- In writing floating point values: Make sure that Modbus controller’s endian configuration matches that of the actuator. If the endian configurations do not match, a legal value may be transformed into an illegal one.
- A write to only one of the floating point registers in a two register set will be ignored.
- On heterogeneous device networks, a broadcast message to a different device type may be interpreted by the Beck actuator as a command to change a configuration parameter. Because of this, it is recommended that under these circumstances, the actuator should be configured to ignore broadcast messages.

APPENDIX Modbus Message Formats

Overview

Beck Modbus actuators support the Modbus RTU message format. A Modbus RTU message consists of the address, function code, data and checksum. There is a response silent interval (t3.5) of approximately 4 character periods before the actuator responds to a message request as required by the Modbus specification.



Polling Address

The polling address is the assigned address that the Beck Actuator will respond to (all other addresses are ignored). The Beck Modbus interface polling address can be configured to a value between 1 and 247. There are 2 ways to configure the polling address:

- Modbus holding register: **40018**.
- Serial command: **modpolladdr**.

Broadcast Messages

Broadcast Messages (Address 0) are messages that are received by all Modbus devices on a network and are acted upon without responding.

In homogeneous networks (for example, a network consisting of only Beck Actuators), a single broadcast message can be used to send a setpoint or to set a coil for all connected devices.

In heterogeneous networks of mixed device types, a broadcast message intended for one group of devices may trigger an unintended function in another device, possibly upsetting a control process. Because of the potential problems of broadcast messages, a Serial command to disable processing of these messages has been provided: The “modconfig” Serial Command.

Function Codes Supported

Modbus function codes define different message formats. Beck Modbus actuators support the following function codes:

Function Code	Description	Exception Codes
01	Read Multiple Coils (1-2000)	01-04
02	Read Multiple Discrete Inputs (1-2000)	01-04
03	Read Multiple Holding Registers (1-125)	01-04
04	Read Multiple Input Registers (1-125)	01-04
05	Write Single Coil	01-04
06	Write Single Register	01-04
08	Diagnostics	01, 03 or 04
15	Write Multiple Coils (1-1968)	01-04
16	Write Multiple Registers (1-123)	01-04
17	Report Server ID	01 or 04

APPENDIX *Modbus Message Formats*

Function Code 8 Message Format

Function Code 8 is used for testing the Serial Interface and returning diagnostic information. This function also provides for a series of diagnostic counters that track the DCM's view of the quality of the communications link. This function also provides a loopback test that simply echos out incoming data to verify the link quality. All diagnostic counters are unsigned 32 bit numbers.

Hex	Decimal	Name	Description
0x00	00	Return Query Data (Loopback)	Maximum test message length is 32 bytes.
0x01	01	Restart Communications Option	Restart the actuator Serial line port and clear all communications event counters.
0x02	02	Return Diagnostic Register	Return the actuator diagnostic register.
0x0A	10	Clear Counters and Diagnostic Register	Clear all counters and the diagnostic register. Counters are also cleared upon power-up.
0x0B	11	Return Bus Message Count	Return the quantity of messages that the remote device has detected on the communications system since its last restart.
0x0C	12	Return Bus Communication Error Count	Return the quantity of CRC errors encountered by the actuator since its last restart, clear counters operation, or power-up.
0x0D	13	Return Bus Exception Error Count	Return the quantity of MODBUS exception responses returned by the actuator since its last restart, clear counters operation, or power-up.

APPENDIX Modbus Message Formats

Function Code 17 Message Format

Function Code 17 is used by control systems to identify server devices. Unlike other Modbus RTU messages, the results from this function are ASCII. The format of the response is:

FC17 Byte	Description
0	Server ID: Enumerated value DCM-3 = 0 , DCM-2 (G22) = 1 , Group 57 = 2.
1	Run Indicator Equals 0x00 if both CCW and CW inhibitors are not equal to zero. Equals 0xFF if either CCW or CW inhibitor is zero.
2 to 32	MFG ID, Revision, and Device ID: BECK XX.XX/DM-YY NNNNNN. Padded with spaces.
33 to 54	Actuator Serial Number: GG-MMM-WWWWWW-XX-YY. Padded with spaces.
55 to 65	Position Sensor Serial Number: CPS NNNNNN . Padded with spaces.

Process Variable Data Formats

Scaled Integer Register Set

The Scaled Integer Register Set represents a 0% to 100% of full scale value for the position, setpoint or torque process variables using a 16 bit signed integer. To support the many numeric scaling formats used in industry, direct emulation of the most popular set of typical actuator interfaces have been provided for.

The following input (read only) registers are part of this register set:

- Position (position_scaled at Register 30008)
- Torque (torque_scaled at Register 30009)

The following holding (read/write) registers are part of this set:

- Demand (demand_scaled at Register 40007)
- Scaling Type (scaling_type at Register 40006)

To set the type of scaling, the scaling type parameter (scaling_type) can be set using:

- The “modscaling” Beck command.
- The “scaling_type” (40006) holding register via function code 6 or 16.

See the description of the “modscaling” Beck command for the details on configuring this parameter.

Floating Point Register Set

IEEE-754 is the standard used to define the format of a floating point number. The Beck Modbus actuator provides the following IEEE-754 Floating-Point format register sets:

- Demand (Registers 40001 and 40002)
- Position (Registers 30001 and 30002)
- Torque (Registers 30004 and 30005)

All units are in percent and represent percentage of full scale value. Note floating-point holding registers are grouped as a protected Modbus holding register set.

Floating Point Byte Order

While the IEEE-754 standard defines the floating point numeric format, it does not control how the underlying bytes are stored in a particular system. In computing, the sequence in which bytes are arranged to make up a larger component is called endianness. While Modbus appears to be natively “big endian”, there is no assurance that a control system will assemble the 4 floating point bytes received for each process variable in that fashion. To handle systems which are other than “big endian”, the Beck Modbus interface provides for 4 different endian formats. Those formats are:

- Endian Type 0: Big Endian.
- Endian Type 1: Middle-Little Endian.
- Endian Type 2: Little Endian.
- Endian Type 3: PDP Endian.

In the example below, the floating point number “123.456” is translated into the 4 different endian formats:

Modbus Floating Point Example

Value 123.456 (0x42F6E979 / Bytes 66,246,233 and 121)

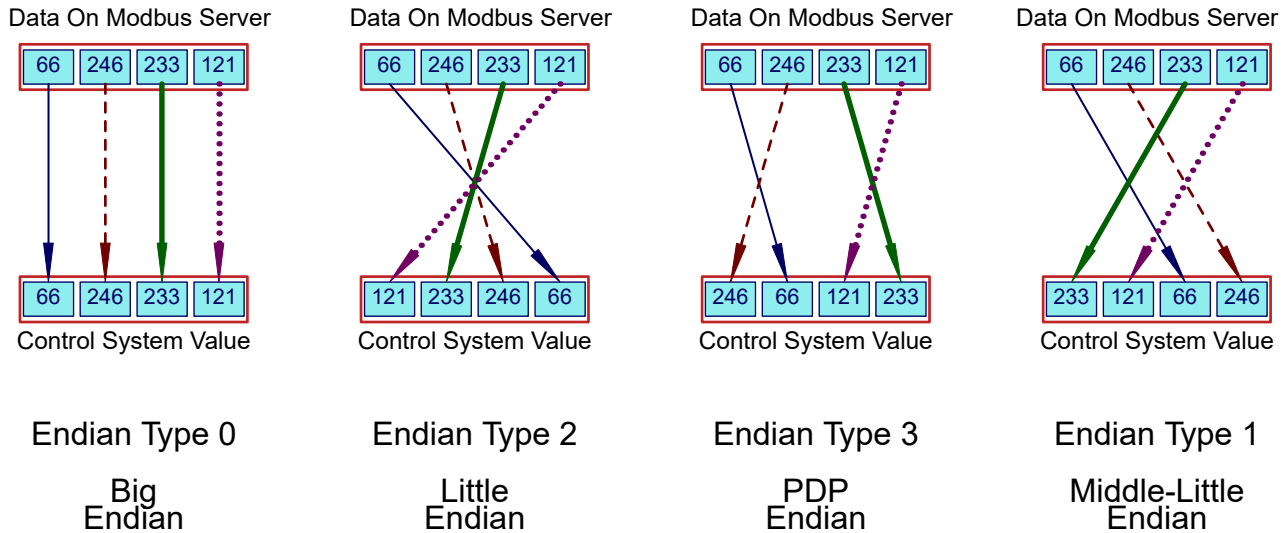

Endian Configuration Options

Endianness is configurable using the following options:

- The “modendian” Beck Command.
- The endian_format Modbus holding register at 40004.

Protected Modbus Holding Register Sets

Because the basic Modbus data unit is 16 bits, certain parameters that exceed that size are made up of more than one register. If only one of the registers were updated, it would be possible to corrupt the underlying parameter by mating two unrelated pieces of a larger data item. The Beck Modbus interface provides for protection against this possibility by implementing the following restrictions for multi-register Modbus parameters:

- Contiguous Write Restrictions: All registers in a set must be written in contiguous Modbus transactions in any order.
- Timing Restrictions: All registers in a set must be written within a certain time window or the value will be rejected.

Register sets of this type are called Protected Modbus Holding Register Sets. These sets are shown on the next page.

APPENDIX Modbus Message Formats

Protected Modbus Holding Register Set Groups		
Group	Register	Description
Group A	40002	demand_value_float_1
	40001	demand_value_float_0
Group B	40020	deadband_value_1_0
	40021	deadband_value_1_1
Group C	40022	deadband_value_2_0
	40023	deadband_value_2_1
Group D	40030	feedback_range_lower_0
	40031	feedback_range_lower_1
Group E	40032	feedback_range_upper_0
	40033	feedback_range_upper_1
Group F	40037	trq_thrust_span_0
	40038	trq_thrust_span_1
Group G	40039	trq_thrust_zero_0
	40040	trq_thrust_zero_1
Group H	40041	trq_thrust_limit_upper_0
	40042	trq_thrust_limit_upper_1
Group I	40045	shutdown_trq_thrust_level_0
	40046	shutdown_trq_thrust_level_1
Group J	40049	drive_stall_time_0
	40050	drive_stall_time_1
Group K	40052	travelspan_value_0
	40053	travelspan_value_1
Group L	40054	maximum_rated_travel_span_engunits_0
	40055	maximum_rated_travel_span_engunits_1
Group M	40057	overtravel_annunciation_level_0
	40058	overtravel_annunciation_level_1
Group N	40062	drive_gear_ratio_0
	40063	drive_gear_ratio_1
Group O	40064	drive_motor_poles_0
	40065	drive_motor_poles_1
Group P	40069	inch_per_rev_0
	40070	inch_per_rev_1

String Register Format

Multiple Modbus registers are also be used to transfer strings. The order of string transfer is independent of the floating point endian format parameter at Register 40004. Strings are mapped to consecutive Modbus registers beginning with the first register in the dataset. The first register contains the first two characters of the string with the high order byte storing the first character and the low order byte storing the second character. The remaining characters are mapped the same way in the register set. Parameters with odd numbers of bytes are padded with spaces.

Ambient Temperature Format

Ambient temperature is represented as two 16 bit registers with signed unscaled representation for Celsius and Fahrenheit. The registers are:

- Celsius: ambient_value_degC at Register 30032.
- Fahrenheit: ambient_value_degF at Register 30033.

APPENDIX Modbus Parameter Maps

The Modbus Parameter Maps that follow describe the Coils, Discrete Inputs, Input Registers and Holding Registers for all Beck products. Where indicated in the “**Note**” column, the following apply:

Parameter Map Notes

Note 1: The indicated parameter is never available for this model. Unsupported parameters are included for information only and to allow a common Modbus template for all Beck Actuators. In most cases, unsupported Modbus parameters will read zero. Attempts to write to this parameter may return an exception code.

Note 2: The indicated parameter may be available if optional hardware is installed and enabled.

Note 3: The Register is a bit array. Not all bits will be active for this model (see the Modbus Binary Signal Map on page 86).

COIL PARAMETER MAP

Coil Parameter Map					
Coil No.	Hex Address	ID	Type	Description	Note*
00001	0x0000	actuator_stop_override_coil_0x01	Process	ACTUATOR_STOP_OVERRIDE_COIL: Setting this coil activates the STOP override coil which causes the actuator to stop at the present and reject all transmitted setpoints. All other setpoint coils (0PCT and 100PCT) will be ignored when this coil is set. All override coils must be cleared to return to automatic control. See “Demand (Setpoint) Hierarchy” Section on page 89.	
00002	0x0001	actuator_100pct_override_coil_0x02	Process	ACTUATOR_100PCT_OVERRIDE_COIL: Setting this coil activates the 100PCT setpoint override coil. See “Demand (Setpoint) Hierarchy” Section on page 89.	
00003	0x0002	actuator_0pct_override_coil_0x04	Process	ACTUATOR_0PCT_OVERRIDE_COIL: Setting this coil activates the 0PCT override coil. See “Demand (Setpoint) Hierarchy” Section on page 89.	

*See above for “Note” column description.

DISCRETE INPUT PARAMETER MAP

Beck Modbus Basic Parameter Set: Discrete Input Address Map					
DI No.	Hex Address	ID	Type	Description	Note*
10001	0x0000	xmtr_specific_status_0_0x01	Process	ALARM_DEMAND_LOS: The Demand Signal is outside of the intended limits (see Demand Setup menu).	
10002	0x0001	xmtr_specific_status_0_0x02	Process	ALARM_TRQ_THRUST_OVERRANGE: The Torque/Thrust is greater than the output rating.	2
10003	0x0002	xmtr_specific_status_0_0x04	Process	ALARM_STALL: Stall condition has been detected (see **Stall Time** in the **General Setup** menu).	
10004	0x0003	xmtr_specific_status_0_0x08	Process	ALARM_OVERTRQ_THRUST_PROTECTION: Motor power has been removed due to excessive output torque.	2
10005	0x0004	xmtr_specific_status_0_0x10	Process	ALARM_Vac_LOW: Under-voltage protection is blocking operation.	
10006	0x0005	xmtr_specific_status_0_0x20	Process	ALARM_FEEDBACK_DISCONNECTED: The Feedback Signal is enabled but the loop is open.	
10007	0x0006	xmtr_specific_status_0_0x40	Process	ALARM_TEMPERATURE_OVERRANGE: The temperature is outside of -40F to 185F.	
10008	0x0007	xmtr_specific_status_0_0x80	Process	ALARM_POSITION_OVERRANGE: The Position Signal is less than -5% or greater than 105%.	
10009	0x0008	xmtr_specific_status_1_0x01	Process	ERROR_RTC: Real Time Clock hardware failure.	
10010	0x0009	xmtr_specific_status_1_0x02	Process	ERROR_TRQ_THRUST_SENSING: Torque/Thrust sensing error.	2
10011	0x000A	xmtr_specific_status_1_0x04	Process	ERROR_POSITION_SENSING: Position sensing error.	
10012	0x000B	xmtr_specific_status_1_0x08	Process	ERROR_DEMAND_SENSING: Demand sensing error.	
10013	0x000C	xmtr_specific_status_1_0x10	Process	ERROR_FRAM: FRAM Memory has failed.	
10014	0x000D	xmtr_specific_status_1_0x20	Process	ERROR_POSITION_LOS: Position signal in LOS.	
10015	0x000E	xmtr_specific_status_1_0x40	Process	ERROR_TEMPERATURE_AD: Temperature A/D Fail.	
10016	0x000F	xmtr_specific_status_1_0x80	Process	ERROR_RAM_ROM: Memory failure.	

*See above for “Note” column description.

APPENDIX Modbus Parameter Maps

Discrete Input Parameter Map (cont'd)

Beck Modbus Basic Parameter Set: Discrete Input Address Map					
DI No.	Offset	ID	Type	Description	Note*
10017	0x0010	xmtr_specific_status_2_0x01	Process	ILLEGAL_PB_PRESS: Local control button pressed while locked-out	
10018	0x0011	xmtr_specific_status_2_0x02	Process	DMND_OVER_LIMIT: Demand Signal is out of limit	
10019	0x0012	xmtr_specific_status_2_0x04	Process	UNUSED	
10020	0x0013	xmtr_specific_status_2_0x08	Process	Vac_NOT_READY: Power Source Not Nominal	
10021	0x0014	xmtr_specific_status_2_0x10	Process	HS NOT IN AUTO: The Handswitch is not in the auto position.	
10022	0x0015	xmtr_specific_status_2_0x20	Process	UNUSED	
10023	0x0016	xmtr_specific_status_2_0x40	Process	UNUSED	
10024	0x0017	xmtr_specific_status_2_0x80	Process	UNUSED	
10025	0x0018	xmtr_specific_status_3_0x01	Process	UNDEFINED_3_0: Xmtr Alarm 3 Bit 0	
10026	0x0019	xmtr_specific_status_3_0x02	Process	UNDEFINED_3_1: Xmtr Alarm 3 Bit 1	
10027	0x001A	xmtr_specific_status_3_0x04	Process	DMND_DET_UNDER_DIGITAL: Loop Current Detected while under Modbus/FF Control.	
10028	0x001B	xmtr_specific_status_3_0x08	Process	DMND_DET_UNDER_PAT: Loop Current Detected while set for LOS PAT.	
10029	0x001C	xmtr_specific_status_3_0x10	Process	UNDEFINED_3_4: Xmtr Alarm 3 Bit 4	
10030	0x001D	xmtr_specific_status_3_0x20	Process	UNDEFINED_3_5: Xmtr Alarm 3 Bit 5	
10031	0x001E	xmtr_specific_status_3_0x40	Process	UNDEFINED_3_6: Xmtr Alarm 3 Bit 6	
10032	0x001F	xmtr_specific_status_3_0x80	Process	UNDEFINED_3_7: Xmtr Alarm 3 Bit 7	
10034	0x0021	analog_output_fixed1_0x01	Process	ERROR_FIXED_FDBK: Feedback is in fixed mode	
10035	0x0022	analog_output_saturated1_0x01	Process	ERROR_POSITION_OOL: Position out of accurate measurement range	
10036	0x0023	analog_output_saturated1_0x02	Process	ERROR_DEMAND_OOL: Demand out of accurate measurement range	
10037	0x0024	analog_output_saturated1_0x04	Process	ERROR_AMBIENT_OOL: Temperature out of accurate measurement range	
10038	0x0025	analog_output_saturated1_0x08	Process	ERROR_TRQ_THRUST_OOL: Torque/Thrust out of accurate measurement range	2
10040	0x0027	logic_level_inputs_status_0x01	Process	LIMIT_CCW: *ON* indicates that the CCW over-travel limit switch has been reached.	
10041	0x0028	logic_level_inputs_status_0x02	Process	LIMIT_CW: *ON* indicates that the CW over-travel limit switch has been reached.	
10042	0x0029	logic_level_inputs_status_0x20	Process	HNDSW_CCW: *ON* indicates that the Handswitch is in the CCW position.	
10043	0x002A	logic_level_inputs_status_0x40	Process	HNDSW_CW: *ON* indicates that the Handswitch is in the CW position.	
10044	0x002B	logic_level_inputs_status_0x80	Process	HNDSW_AUTO: *ON* indicates that the Handswitch is in the AUTO position.	
10045	0x002C	logic_level_inputs_status_0xE0	Process	HNDSW_OK: *ON* indicates that the Handswitch has been detected.	
10053	0x0034	led_status_0x0040	Process	POSITION_GREEN_LED: The Output shaft position has reached the limits configured for the Green Indicator.	
10054	0x0035	led_status_0x0080	Process	POSITION_RED_LED: The Output shaft position has reached the limits configured for the Red Indicator.	
10111	0x006E	bpu_status_0x0001	Process	BPU_STATUS_LOP_ACTIVE: *ON* indicates that the actuator is running on backup power (BPU Equipped Models Only).	2
10112	0x006F	bpu_status_0x0002	Process	BPU_STATUS_LOP_PENDING: *ON* indicates that the actuator power supply has just dropped below the BPU alarm threshold (BPU Equipped Models Only).	2

*See page 99 for "Note" column description.

Beck Modbus Basic Parameter Set: Discrete Input Address Map					
DI No.	Offset	ID	Type	Description	Note*
10113	0x0070	bpu_status_0x0004	Process	BPU_STATUS_CHARGE_TIMEOUT: *ON* indicates that the backup power unit has not reported as fully charged for an extended period (BPU Equipped Models Only).	2
10114	0x0071	bpu_status_0x0008	Process	BPU_STATUS_MAINTENANCE_DATE_OVER_LIMIT: *ON* indicates that BPU installation date has exceeded the programmed BPU Maintenance Interval (BPU Equipped Models Only).	2
10115	0x0072	bpu_status_0x0010	Process	BPU_STATUS_MAN_DISCHARGE_ACTIVE: *ON* indicates that the manual discharge button has been depressed (BPU Equipped Models Only).	2
10116	0x0073	bpu_status_0x0020	Process	BPU_STATUS_LOW_OUT_VOLTS: *ON* indicates that the BPU output voltage is below the 9.8V UVolt Level (BPU Equipped Models Only).	2
10117	0x0074	bpu_status_0x0040	Process	BPU_STATUS_LOW_CAP_VOLTS: *ON* indicates that the capacitor bank voltage is below 5V (BPU Equipped Models Only).	2
10118	0x0075	bpu_status_0x0080	Process	BPU_STATUS_UNDEFINED_0x0080: UNDEFINED_0x0080 (BPU Equipped Models Only).	2
10119	0x0076	bpu_status_0x0100	Process	BPU_STATUS_UNDEFINED_0x0100: UNDEFINED_0x0100 (BPU Equipped Models Only).	2
10120	0x0077	bpu_status_0x0200	Process	BPU_STATUS_UNDEFINED_0x0200: UNDEFINED_0x0200 (BPU Equipped Models Only).	2
10121	0x0078	bpu_status_0x0400	Process	BPU_STATUS_UNDEFINED_0x0400: UNDEFINED_0x0400 (BPU Equipped Models Only).	2
10122	0x0079	bpu_status_0x0800	Process	BPU_STATUS_UNDEFINED_0x0800: UNDEFINED_0x0800 (BPU Equipped Models Only).	2
10123	0x007A	bpu_status_0x1000	Process	BPU_STATUS_UNDEFINED_0x1000: UNDEFINED_0x1000 (BPU Equipped Models Only).	2
10124	0x007B	bpu_status_0x2000	Process	BPU_STATUS_UNDEFINED_0x2000: UNDEFINED_0x2000 (BPU Equipped Models Only).	2
10125	0x007C	bpu_status_0x4000	Process	BPU_STATUS_UNDEFINED_0x4000: UNDEFINED_0x4000 (BPU Equipped Models Only).	2
10126	0x007D	bpu_status_0x8000	Process	BPU_STATUS_INSTALLED_ACTIVE: *ON* indicates that Backup Power Unit is installed (BPU Equipped Models Only).	2

*See page 99 for "Note" column description.

APPENDIX Modbus Parameter Maps

INPUT REGISTER PARAMETER MAP

Input Register Parameter Map					
Reg. No.	Hex Address	ID	Type	Description	Note*
30001	0x0000	position_value_float_0	Process	position_value_float: Parameter set part 01 of 02 (Byte indexes 01 and 00). Type: FLOAT Position: The present shaft position as measured by the CPS sensor expressed as a percentage. Zero percent position corresponds to the voltage entered in the 'CPS Zero%' value in the position sensor menu. Also see 'Travel'.	
30002	0x0001	position_value_float_1	Process	position_value_float: Parameter set part 02 of 02 (Byte indexes 03 and 02). Type: FLOAT Position: The present shaft position as measured by the CPS sensor expressed as a percentage. Zero percent position corresponds to the voltage entered in the 'CPS Zero%' value in the position sensor menu. Also see 'Travel'.	
30003	0x0002	position_value_float_status	Process	Type: ENUMERATED Position Status: The status associated with position_value_float. Used to recreate a standard DCS Floating Point Structure(DS-65). The value will equal either 'good' if there are no parameter-related alarms or 'bad' if any alarm is active.	
30004	0x0003	torque_value_float_0	Process	torque_value_float: Parameter set part 01 of 02 (Byte indexes 01 and 00). Type: FLOAT Torque/Thrust: The load Torque/Thrust measured at the output shaft– expressed as percentage of the maximum rated Torque/Thrust.	2
30005	0x0004	torque_value_float_1	Process	torque_value_float: Parameter set part 02 of 02 (Byte indexes 03 and 02). Type: FLOAT Torque/Thrust: The load Torque/Thrust measured at the output shaft– expressed as percentage of the maximum rated Torque/Thrust.	2
30006	0x0005	torque_value_float_status	Process	Type: ENUMERATED Torque/Thrust Status: The status associated with torque_value_float. Used to recreate a standard DCS Floating Point Structure– DS-65. The value will equal either 'good' if there are no parameter-related alarms or 'bad' if any alarm is active.	2
30008	0x0007	position_scaled	Process	Type: UNSIGNED_INTEGER The output shaft position expressed in percent of span scaled to the range chosen by the 'scaling_type' parameter.	
30009	0x0008	torque_scaled	Process	Type: UNSIGNED_INTEGER Torque/Thrust: The load Torque/Thrust measured at the output shaft– expressed as percentage of the maximum rated Torque/Thrust scaled to the range chosen by the 'scaling_type' parameter.	2
30014	0x000D	beck_drive_designation_readonly_0	Configuration	beck_drive_designation_readonly: Parameter set part 01 of 10 (Byte indexes 01 and 00). Type: ASCII(20) Present value of the Drive Serial Number: Unique Serial number associated with the Beck actuator. This number is stamped on the nameplate.	
30015	0x000E	beck_drive_designation_readonly_1	Configuration	beck_drive_designation_readonly: Parameter set part 02 of 10 (Byte indexes 03 and 02). Type: ASCII(20) Present value of the Drive Serial Number: Unique Serial number associated with the Beck actuator. This number is stamped on the nameplate.	
30016	0x000F	beck_drive_designation_readonly_2	Configuration	beck_drive_designation_readonly: Parameter set part 03 of 10 (Byte indexes 05 and 04). Type: ASCII(20) Present value of the Drive Serial Number: Unique Serial number associated with the Beck actuator. This number is stamped on the nameplate.	

*See page 99 for "Note" column description.

Input Register Parameter Map					
Reg. No.	Hex Address	ID	Type	Description	Note*
30017	0x0010	beck_drive_designation_readonly_3	Configuration	beck_drive_designation_readonly: Parameter set part 04 of 10 (Byte indexes 07 and 06). Type: ASCII(20) Present value of the Drive Serial Number: Unique Serial number associated with the Beck actuator. This number is stamped on the nameplate.	
30018	0x0011	beck_drive_designation_readonly_4	Configuration	beck_drive_designation_readonly: Parameter set part 05 of 10 (Byte indexes 09 and 08). Type: ASCII(20) Present value of the Drive Serial Number: Unique Serial number associated with the Beck actuator. This number is stamped on the nameplate.	
30019	0x0012	beck_drive_designation_readonly_5	Configuration	beck_drive_designation_readonly: Parameter set part 06 of 10 (Byte indexes 11 and 10). Type: ASCII(20) Present value of the Drive Serial Number: Unique Serial number associated with the Beck actuator. This number is stamped on the nameplate.	
30020	0x0013	beck_drive_designation_readonly_6	Configuration	beck_drive_designation_readonly: Parameter set part 07 of 10 (Byte indexes 13 and 12). Type: ASCII(20) Present value of the Drive Serial Number: Unique Serial number associated with the Beck actuator. This number is stamped on the nameplate.	
30021	0x0014	beck_drive_designation_readonly_7	Configuration	beck_drive_designation_readonly: Parameter set part 08 of 10 (Byte indexes 15 and 14). Type: ASCII(20) Present value of the Drive Serial Number: Unique Serial number associated with the Beck actuator. This number is stamped on the nameplate.	
30022	0x0015	beck_drive_designation_readonly_8	Configuration	beck_drive_designation_readonly: Parameter set part 09 of 10 (Byte indexes 17 and 16). Type: ASCII(20) Present value of the Drive Serial Number: Unique Serial number associated with the Beck actuator. This number is stamped on the nameplate.	
30023	0x0016	beck_drive_designation_readonly_9	Configuration	beck_drive_designation_readonly: Parameter set part 10 of 10 (Byte indexes 19 and 18). Type: ASCII(20) Present value of the Drive Serial Number: Unique Serial number associated with the Beck actuator. This number is stamped on the nameplate.	
30025	0x0018	beck_software_revision_0	Configuration	beck_software_revision: Parameter set part 01 of 02 (Byte indexes 01 and 00). Type: FLOAT DCM Software Revision: The version of software operating in this Beck circuit board.	
30026	0x0019	beck_software_revision_1	Configuration	beck_software_revision: Parameter set part 02 of 02 (Byte indexes 03 and 02). Type: FLOAT DCM Software Revision: The version of software operating in this Beck circuit board.	
30027	0x001A	device_id_0	Configuration	device_id: Parameter set part 01 of 02 (Byte indexes 01 and 00). Type: UNSIGNED_INTEGER(4) Device Id: Unique Serial number associated with the digital control module (DCM). This number is printed on a label affixed to the module CPU.	
30028	0x001B	device_id_1	Configuration	device_id: Parameter set part 02 of 02 (Byte indexes 03 and 02). Type: UNSIGNED_INTEGER(4) Device Id: Unique Serial number associated with the digital control module (DCM). This number is printed on a label affixed to the module CPU.	
30032	0x001F	ambient_value_degc	Process	Type: INTEGER Ambient Value Degrees C: The ambient temperature in Celsius measured at the DCM circuit board expressed as a single signed 16 bit integer with no scaling.	

*See page 99 for "Note" column description.

APPENDIX Modbus Parameter Maps

Input Register Parameter Map (cont'd)

Input Register Parameter Map					
Reg. No.	Hex Address	ID	Type	Description	Note*
30033	0x0020	ambient_value_degF	Process	Type: INTEGER Ambient Value Degrees F: The ambient temperature in Fahrenheit measured at the DCM circuit board expressed as a single signed 16 bit integer with no scaling.	
30038	0x0025	position_scaled_duplicate	Process	Type: INTEGER A copy of the position_scaled register placed near the status bits. This duplicate allows process variables and status to be read as one multi-register block. The output shaft position expressed in percent of span scaled to the range chosen by the 'scaling_type' parameter.	
30039	0x0026	torque_scaled_duplicate	Process	Type: INTEGER A copy of the position_scaled register placed near the status bits. This duplicate allows process variables and status to be read as one multi-register block. Torque/Thrust: The load Torque/Thrust measured at the output shaft - expressed as percentage of the maximum rated Torque/Thrust scaled to the range chosen by the 'scaling_type' parameter.	2
30040	0x0027	demand_scaled_duplicate	Process	Type: INTEGER A copy of the position_scaled register placed near the status bits. This duplicate allows process variables and status to be read as one multi-register block. The effective demand value. If in 'HOLD' (Modbus) Mode - editing this value will control the motor set point unless an alarm condition exists. It is expressed in percent of span scaled to the range chosen by the 'scaling_type' parameter.	
30041	0x0028	xmtr_specific_status_1_0	Process	Type: UNSIGNED_INTEGER Register representation of discrete inputs xmtr_specific_status_1 and 0. See the "MODBUS BINARY SIGNAL MAP" on page 90 for details.	3
30042	0x0029	xmtr_specific_status_3_2	Process	Type: UNSIGNED_INTEGER Register representation of discrete inputs xmtr_specific_status_3 and 2. See the "MODBUS BINARY SIGNAL MAP" on page 90 for details.	3
30043	0x002A	analog_output_fixed1_saturated1	Process	Type: UNSIGNED_INTEGER Register representation of discrete inputs analog_output_fixed1 and analog_output_saturated1. See the "MODBUS BINARY SIGNAL MAP" on page 90 for details.	3
30044	0x002B	logic_level_inputs_status	Process	Present value of the handswitch, limit switch and override inputs. Not supported in all models. Support for reading these signals can be determined using registers 30094 and 30095. See description of Registers 30094 and 30095 for details. See the "MODBUS BINARY SIGNAL MAP" on page 90 for details.	
30045	0x002C	ccw_ext_movement_status_2_1	Process	Type: UNSIGNED_INTEGER Register representation of the counter-clockwise inhibitor bit array. When this value equals zero- the actuator can proceed in the counter-clockwise direction unless otherwise blocked.	
30046	0x002D	cw_ext_movement_status_2_1	Process	Type: UNSIGNED_INTEGER Register representation of the clockwise inhibitor bit array. When this value equals zero- the actuator can proceed in the clockwise direction unless otherwise blocked.	
30057	0x0038	drive_accumulated_runtime_0	Process	drive_accumulated_runtime: Parameter set part 01 of 02 (Byte indexes 01 and 00).Type: FLOAT Accumulated Running Time: The total accumulated motor run time since factory shipment.	

*See page 99 for "Note" column description.

Input Register Parameter Map					
Reg. No.	Hex Address	ID	Type	Description	Note*
30058	0x0039	drive_accumulated_runtime_1	Process	drive_accumulated_runtime: Parameter set part 02 of 02 (Byte indexes 03 and 02).Type: FLOAT Accumulated Running Time: The total accumulated motor run time since factory shipment.	
30059	0x003A	drive_overtorques_0	Process	drive_overtorques: Parameter set part 01 of 02 (Byte indexes 01 and 00).Type: FLOAT Overthrusts: The total number of times excessive Thrust was detected at the output shaft since factory shipment.	2
30060	0x003B	drive_overtorques_1	Process	drive_overtorques: Parameter set part 02 of 02 (Byte indexes 03 and 02).Type: FLOAT Overthrusts: The total number of times excessive Thrust was detected at the output shaft since factory shipment.	2
30061	0x003C	drive_peak_torque_0	Process	drive_peak_torque: Parameter set part 01 of 02 (Byte indexes 01 and 00).Type: FLOAT Peak Thrust: The maximum thrust sensed at the output shaft since factory shipment.	2
30062	0x003D	drive_peak_torque_1	Process	drive_peak_torque: Parameter set part 02 of 02 (Byte indexes 03 and 02).Type: FLOAT Peak Thrust: The maximum thrust sensed at the output shaft since factory shipment.	2
30063	0x003E	drive_reversals_0	Process	drive_reversals: Parameter set part 01 of 02 (Byte indexes 01 and 00).Type: FLOAT Reversals: The total number of times the motor started in a direction opposite to the previous start since factory shipment.	
30064	0x003F	drive_reversals_1	Process	drive_reversals: Parameter set part 02 of 02 (Byte indexes 03 and 02).Type: FLOAT Reversals: The total number of times the motor started in a direction opposite to the previous start since factory shipment.	
30065	0x0040	drive_run_time_0	Process	drive_run_time: Parameter set part 01 of 02 (Byte indexes 01 and 00).Type: FLOAT Last Run Time: The duration of the last motor movement.	
30066	0x0041	drive_run_time_1	Process	drive_run_time: Parameter set part 02 of 02 (Byte indexes 03 and 02).Type: FLOAT Last Run Time: The duration of the last motor movement.	
30067	0x0042	drive_stalls_0	Process	drive_stalls: Parameter set part 01 of 02 (Byte indexes 01 and 00).Type: FLOAT Stalls: The total number of Stall conditions since factory shipment.	
30068	0x0043	drive_stalls_1	Process	drive_stalls: Parameter set part 02 of 02 (Byte indexes 03 and 02).Type: FLOAT Stalls: The total number of Stall conditions since factory shipment.	
30069	0x0044	drive_starts_0	Process	drive_starts: Parameter set part 01 of 02 (Byte indexes 01 and 00).Type: FLOAT Starts: The total number motor starts since factory shipment.	
30070	0x0045	drive_starts_1	Process	drive_starts: Parameter set part 02 of 02 (Byte indexes 03 and 02).Type: FLOAT Starts: The total number motor starts since factory shipment.	
30071	0x0046	setup_num_Overthrusts_0	Process	setup_num_Overthrusts: Parameter set part 01 of 02 (Byte indexes 01 and 00).Type: FLOAT StartUp Over-Thrusts: The number of times the output shaft torque exceeded the Thrust Alarm ('ThrAlrmUpLmt') threshold during installation.	2

*See page 99 for "Note" column description.

APPENDIX Modbus Parameter Maps

Input Register Parameter Map (cont'd)

Input Register Parameter Map					
Reg. No.	Hex Address	ID	Type	Description	Note*
30072	0x0047	setup_num_overtorques_1	Process	setup_num_overtorques: Parameter set part 02 of 02 (Byte indexes 03 and 02).Type: FLOAT StartUp Over-Thrusts: The number of times the output shaft torque exceeded the Thrust Alarm ('ThrAlrmUpLmt') threshold during installation.	2
30073	0x0048	setup_pk_torque_0	Process	setup_pk_torque: Parameter set part 01 of 02 (Byte indexes 01 and 00).Type: FLOAT StartUp Peak Thrust: The peak thrust recorded during installation.	2
30074	0x0049	setup_pk_torque_1	Process	setup_pk_torque: Parameter set part 02 of 02 (Byte indexes 03 and 02).Type: FLOAT StartUp Peak Thrust: The peak thrust recorded during installation.	2
30076	0x004B	demand_modbus_address_number_last_accepted	Process	Type: UNSIGNED_INTEGER The last ACCEPTED demand (setpoint) Modbus address number stated as an integer value. The number may be that of a coil or holding register. The value 0xFFFF (65535) indicates that no such address has been received.	
30077	0x004C	demand_modbus_address_number_last_rcvd	Process	Type: UNSIGNED_INTEGER The last RECEIVED demand (setpoint) Modbus address number stated as an integer value. The number may be that of a coil or holding register. The value that was transmitted from this Modbus address may have been rejected because it was invalid or the assertion of an actuator override coil (coils 0001 0002 or 0003). The value 0xFFFF (65535) indicates that no such address has been received.	
30079	0x004E	position_raw_value_0	Process	position_raw_value: Parameter set part 01 of 02 (Byte indexes 01 and 00).Type: FLOAT Position Sensor Voltage: Displays the present value of the internal Position Sensor voltage– which can be measured at TP4(+) and TP1(-) on the DCM. This value can be edited in the 'Calibration Trim' menu for trimming the position sensor A/D converter.	
30080	0x004F	position_raw_value_1	Process	position_raw_value: Parameter set part 02 of 02 (Byte indexes 03 and 02).Type: FLOAT Position Sensor Voltage: Displays the present value of the internal Position Sensor voltage– which can be measured at TP4(+) and TP1(-) on the DCM. This value can be edited in the 'Calibration Trim' menu for trimming the position sensor A/D converter.	
30081	0x0050	trq_thrust_raw_value_0	Process	trq_thrust_raw_value: Parameter set part 01 of 02 (Byte indexes 01 and 00).Type: FLOAT Torque/Thrust TK counts: Displays the present value of the load sensor– TK units represent the internal Torque/Thrust Sensor signal level.	2
30082	0x0051	trq_thrust_raw_value_1	Process	trq_thrust_raw_value: Parameter set part 02 of 02 (Byte indexes 03 and 02).Type: FLOAT Torque/Thrust TK counts: Displays the present value of the load sensor– TK units represent the internal Torque/Thrust Sensor signal level.	2
30083	0x0052	ambient_value_high_0	Process	ambient_value_high: Parameter set part 01 of 02 (Byte indexes 01 and 00).Type: FLOAT	
30084	0x0053	ambient_value_high_1	Process	ambient_value_high: Parameter set part 02 of 02 (Byte indexes 03 and 02).Type: FLOAT	
30085	0x0054	ambient_value_low_0	Process	ambient_value_low: Parameter set part 01 of 02 (Byte indexes 01 and 00).Type: FLOAT	
30086	0x0055	ambient_value_low_1	Process	ambient_value_low: Parameter set part 02 of 02 (Byte indexes 03 and 02).Type: FLOAT	

*See page 99 for "Note" column description.

Input Register Parameter Map					
Reg. No.	Hex Address	ID	Type	Description	Note*
30088	0x0057	line_frequency	Configuration	Type: INTEGER Line Frequency: Connection to 50 Hz or 60 Hz power mains.	
30089	0x0058	present_frequency_0	Process	present_frequency: Parameter set part 01 of 02 (Byte indexes 01 and 00).Type: FLOAT Pres Freq: The present motor power frequency.	
30090	0x0059	present_frequency_1	Process	present_frequency: Parameter set part 02 of 02 (Byte indexes 03 and 02).Type: FLOAT Pres Freq: The present motor power frequency.	
30091	0x005A	dc_volts_0	Process	dc_volts: Parameter set part 01 of 02 (Byte indexes 01 and 00).Type: FLOAT DC Volts: The present bus voltage for actuators with variable speed capability.	
30092	0x005B	dc_volts_1	Process	dc_volts: Parameter set part 02 of 02 (Byte indexes 03 and 02).Type: FLOAT DC Volts: The present bus voltage for actuators with variable speed capability.	
30094	0x005D	hs_is_logic_level	Configuration	When this register value is greater than zero, the handswitch works through the DCM and is available via Modbus. When the value is zero, the handswitch signals are not available and will always read zero.	
30095	0x005E	limits_are_logic_level	Configuration	When this register value is greater than zero, the limit switches work through the DCM and are available via Modbus. When the value is zero, the limit switch signals are not available and will always read zero.	

HOLDING REGISTER PARAMETER MAP

Holding Register Parameter Map					
Reg. No.	Hex Address	ID	Type	Description	Note*
40001	0x0000	demand_value_float_0	Process	demand_value_float: Parameter set part 01 of 02 (Byte indexes 01 and 00).Type: FLOAT Demand Value: Effective Demand signal. If in 'HOLD' (Modbus) Mode- editing this value will control the motor set point unless an alarm condition exists. Valid values are between -5% and 105%.	
40002	0x0001	demand_value_float_1	Process	demand_value_float: Parameter set part 02 of 02 (Byte indexes 03 and 02).Type: FLOAT Demand Value: Effective Demand signal. If in 'HOLD' (Modbus) Mode- editing this value will control the motor set point unless an alarm condition exists. Valid values are between -5% and 105%.	
40003	0x0002	demand_value_float_status	Process	Type: INTEGER Demand Status: The status associated with demand_value_float. Used to recreate a standard DCS Floating Point Structure (DS-65). The value will equal either 'good' if there are no parameter-related alarms or 'bad' if any alarm is active.	
40004	0x0003	endian_format	Configuration	Type: ENUMERATED The byte order for all dual Modbus registers representing a 32 byte parameter. This is an enumerated value with a valid range of 0-3. Big Endian=0 Middle-Little Endian=1 Little Endian= 2 PDP Endian=3	
40006	0x0005	scaling_type	Configuration	Type: ENUMERATED The type of scaling applied to the scaled integer register set. The scaling range is an enumerated value. The default value is 0.	

*See page 99 for "Note" column description.

APPENDIX Modbus Parameter Maps

Holding Register Parameter Map (cont'd)

Holding Register Parameter Map					
Reg. No.	Hex Address	ID	Type	Description	Note*
40007	0x0006	demand_scaled	Process	Type: INTEGER The effective demand value. If in 'HOLD' (Modbus) Mode- editing this value will control the motor set point unless an alarm condition exists. It is expressed in percent of span scaled to the range chosen by the 'scaling_type' parameter.	
40013	0x000C	drive_direction	Configuration	Type: ENUMERATED Drive Direction: Defines the direction of output shaft rotation for an increasing Demand signal. Rotation direction is viewed facing the exposed output shaft end.	
40014	0x000D	drive_operating_mode	Process	Type: ENUMERATED Operating Mode: Defines the fundamental manual or automatic Position control mode. 'Follow' mode will cause positioning according to the analog Demand signal. 'Hold' mode will cause positioning according to the HART/FF Interface Demand Value. 'Stay' mode will cause the output to remain stationary and to maintain the present position. In 'Stay' mode- the motor handwheel can NOT be freely turned. 'Stop' mode removes power from the motor. In 'Stop' mode- the motor handwheel can be freely turned. 'Run' modes will cause the shaft to move to the end of travel. All operating modes can be overridden by the actuator handswitch.	
40016	0x000F	modbus_baudrate	Configuration	Type: ENUMERATED The baudrate selector for the Modbus interface. Selection values are: 0=300... 1=600... 2=1200... 3=2400... 4=4800... 5=9600... 6=19200... 7=38400.	
40017	0x0010	modbus_parity	Configuration	Type: ENUMERATED The parity selector for the Modbus interface. Selection values are: 0=EVEN/ ONE STOP BIT ... 1=ODD/ONE STOP BIT ... 2=NONE/TWO STOP BITS ... 3=NONE/ONE STOP BIT.	
40018	0x0011	modbus_address	Configuration	Type: INTEGER The active address of the Modbus interface. Valid values are 1-247. The default value is 246.	
40020	0x0013	deadband_value_1_0	Configuration	deadband_value_1: Parameter set part 01 of 02 (Byte indexes 01 and 00).Type: FLOAT Step Size: The typical change in Demand signal- expressed in percent of span- that can occur before the output shaft will reposition.	
40021	0x0014	deadband_value_1_1	Configuration	deadband_value_1: Parameter set part 02 of 02 (Byte indexes 03 and 02).Type: FLOAT Step Size: The typical change in Demand signal- expressed in percent of span- that can occur before the output shaft will reposition.	
40022	0x0015	deadband_value_2_0	Configuration	deadband_value_2: Parameter set part 01 of 02 (Byte indexes 01 and 00).Type: FLOAT Max Error: The maximum difference- expressed in percent of span- that the automatic control will allow before the output shaft will reposition.	
40023	0x0016	deadband_value_2_1	Configuration	deadband_value_2: Parameter set part 02 of 02 (Byte indexes 03 and 02).Type: FLOAT Max Error: The maximum difference- expressed in percent of span- that the automatic control will allow before the output shaft will reposition.	

*See page 99 for "Note" column description.

Holding Register Parameter Map					
Reg. No.	Hex Address	ID	Type	Description	Note*
40025	0x0018	utility_command_register	Process	Type: ENUMERATED Used to initiate system utilities based on the value in the register. Utility command codes are: 21930 which unstalls the Actuator and 44236 which is used to test communications by blinking the Acknowledge LED on the actuator DCM. During a write operation the register will respond with the value transmitted. When read the register will always equal zero.	
40027	0x001A	pot_power_installed	Configuration	Type: ENUMERATED Potentiometer Power: Defines whether the optional Potentiometer Power Supply function is installed in the DCM.	
40028	0x001B	smart_feedback_installed	Configuration	Type: ENUMERATED Feedback Output: Defines whether the optional Feedback Output function is installed in the DCM.	
40029	0x001C	io_select	Configuration	Type: ENUMERATED Feedback Select: Defines whether the DCM I/O terminal is used to supply a Feedback output signal– to supply power to a Position Sensor potentiometer– or is unused.	
40030	0x001D	feedback_range_lower_0	Configuration	feedback_range_lower: Parameter set part 01 of 02 (Byte indexes 01 and 00).Type: FLOAT Feedback Range Lower: The value of the feedback signal– in mA– that corresponds to a 0% output shaft position. Values can range between 3.0 mA and 16.0mA	
40031	0x001E	feedback_range_lower_1	Configuration	feedback_range_lower: Parameter set part 02 of 02 (Byte indexes 03 and 02).Type: FLOAT Feedback Range Lower: The value of the feedback signal– in mA– that corresponds to a 0% output shaft position. Values can range between 3.0 mA and 16.0mA	
40032	0x001F	feedback_range_upper_0	Configuration	feedback_range_upper: Parameter set part 01 of 02 (Byte indexes 01 and 00).Type: FLOAT Feedback Range Upper: The value of the feedback signal– in mA– that corresponds to a 100% output shaft position. Values can range between 7.0mA and 21.0mA	
40033	0x0020	feedback_range_upper_1	Configuration	feedback_range_upper: Parameter set part 02 of 02 (Byte indexes 03 and 02).Type: FLOAT Feedback Range Upper: The value of the feedback signal– in mA– that corresponds to a 100% output shaft position. Values can range between 7.0mA and 21.0mA	
40035	0x0022	trq_thrust_sensor_installed	Configuration	Type: ENUMERATED Thrust Sensor: Defines whether the optional Thrust Sensing function is installed in the DCM.	
40036	0x0023	trq_thrust_sensor_enabled	Configuration	Type: ENUMERATED Torque/Thrust Display: Defines whether the optional Torque/Thrust Sensing function is enabled in the DCM. If the actuator does not have a torque/thrust sensor– this feature must be disabled.	
40037	0x0024	trq_thrust_span_0	Configuration	trq_thrust_span: Parameter set part 01 of 02 (Byte indexes 01 and 00).Type: FLOAT Torque/Thrust Constant: The value of the load sensor span that corresponds to 100% span. TK units represent the internal Torque/Thrust Sensor signal level.	2
40038	0x0025	trq_thrust_span_1	Configuration	trq_thrust_span: Parameter set part 02 of 02 (Byte indexes 03 and 02).Type: FLOAT Torque/Thrust Constant: The value of the load sensor span that corresponds to 100% span. TK units represent the internal Torque/Thrust Sensor signal level.	2

*See page 99 for "Note" column description.

APPENDIX Modbus Parameter Maps

Holding Register Parameter Map (cont'd)

Holding Register Parameter Map					
Reg. No.	Hex Address	ID	Type	Description	Note*
40039	0x0026	trq_thrust_zero_0	Configuration	trq_thrust_zero: Parameter set part 01 of 02 (Byte indexes 01 and 00). Type: FLOAT Torque/Thrust Null: The value of the load sensor that corresponds to 0%. TK units represent the internal Torque/Thrust Sensor signal level.	2
40040	0x0027	trq_thrust_zero_1	Configuration	trq_thrust_zero: Parameter set part 02 of 02 (Byte indexes 03 and 02). Type: FLOAT Torque/Thrust Null: The value of the load sensor that corresponds to 0%. TK units represent the internal Torque/Thrust Sensor signal level.	2
40041	0x0028	trq_thrust_limit_upper_0	Configuration	trq_thrust_limit_upper: Parameter set part 01 of 02 (Byte indexes 01 and 00). Type: FLOAT Torque/Thrust Alarm Level: Torque/Thrust values greater than this will generate an alarm. This alarm function does not cause the motor to stop. Also see 'ShutDwnTrq/ShutDwnThr'.	2
40042	0x0029	trq_thrust_limit_upper_1	Configuration	trq_thrust_limit_upper: Parameter set part 02 of 02 (Byte indexes 03 and 02). Type: FLOAT Torque/Thrust Alarm Level: Torque/Thrust values greater than this will generate an alarm. This alarm function does not cause the motor to stop. Also see 'ShutDwnTrq/ShutDwnThr'.	2
40044	0x002B	overtrq_thrust_protection	Configuration	Type: ENUMERATED Over-thrust Protection: Defines whether detection of excessive thrust will remove power from the motor.	2
40045	0x002C	shutdown_trq_thrust_level_0	Configuration	shutdown_trq_thrust_level: Parameter set part 01 of 02 (Byte indexes 01 and 00). Type: FLOAT Shutdown Thrust Level: Power will be removed if thrust is greater than this level. This will cause a shutdown alarm. Set this value greater than 'AlarmLevel' to have an alarm before shutdown. Also see 'Ovt Prot'.	2
40046	0x002D	shutdown_trq_thrust_level_1	Configuration	shutdown_trq_thrust_level: Parameter set part 02 of 02 (Byte indexes 03 and 02). Type: FLOAT Shutdown Thrust Level: Power will be removed if thrust is greater than this level. This will cause a shutdown alarm. Set this value greater than 'AlarmLevel' to have an alarm before shutdown. Also see 'Ovt Prot'.	2
40048	0x002F	stall_protection	Configuration	Type: ENUMERATED(1) stall_protection: Removes motor power if stall time is reached. Also see 'Stall Time'.	
40049	0x0030	drive_stall_time_0	Configuration	drive_stall_time: Parameter set part 01 of 02 (Byte indexes 01 and 00). Type: FLOAT Stall Time: The maximum allowable time for the motor to run before the desired position is reached. After this time the Stall condition is set. If stall protection is enabled— power will also be removed from the motor. This value should be set slightly longer than the end to end travel timing. Also see 'StallProt'.	
40050	0x0031	drive_stall_time_1	Configuration	drive_stall_time: Parameter set part 02 of 02 (Byte indexes 03 and 02). Type: FLOAT Stall Time: The maximum allowable time for the motor to run before the desired position is reached. After this time the Stall condition is set. If stall protection is enabled— power will also be removed from the motor. This value should be set slightly longer than the end to end travel timing. Also see 'StallProt'.	
40052	0x0033	travelspan_value_0	Configuration	travelspan_value: Parameter set part 01 of 02 (Byte indexes 01 and 00). Type: FLOAT Travel: the number of degrees/inches/mm of output shaft travel for a 100% span. Edit this value to use a stroke shorter than the allowable 'MaxTravel'. Values higher than 'MaxTravel' are rejected. If values less than 'MaxTravel' are rejected— 'CPS Zero%' may have to be adjusted.	

*See page 99 for "Note" column description.

Holding Register Parameter Map					
Reg. No.	Hex Address	ID	Type	Description	Note*
40053	0x0034	travelspan_value_1	Configuration	travelspan_value: Parameter set part 02 of 02 (Byte indexes 03 and 02).Type: FLOAT Travel: the number of degrees/inches/mm of output shaft travel for a 100% span. Edit this value to use a stroke shorter than the allowable 'MaxTravel'. Values higher than 'MaxTravel' are rejected. If values less than 'MaxTravel' are rejected– 'CPS Zero%' may have to be adjusted.	
40054	0x0035	maximum_rated_travel_span_engunits_0	Configuration	maximum_rated_travel_span_engunits: Parameter set part 01 of 02 (Byte indexes 01 and 00).Type: FLOAT The maximum available travel distance of the output shaft. This value is entered manually– and must correspond to the actuator design. If a shortened stroke is desired– edit 'Travel'.	
40055	0x0036	maximum_rated_travel_span_engunits_1	Configuration	maximum_rated_travel_span_engunits: Parameter set part 02 of 02 (Byte indexes 03 and 02).Type: FLOAT The maximum available travel distance of the output shaft. This value is entered manually– and must correspond to the actuator design. If a shortened stroke is desired– edit 'Travel'.	
40056	0x0037	overtravel_annunciation	Configuration	Type: ENUMERATED Limit Switch Indication: Defines whether contacting a limit switch– outside the normal travel range of 0% to 100%– will cause an error condition.	
40057	0x0038	overtravel_annunciation_level_0	Configuration	overtravel_annunciation_level: Parameter set part 01 of 02 (Byte indexes 01 and 00).Type: FLOAT overtravel_annunciation_level is used in conjunction with overtravel_annunciation to set a zone at the ends of travel where STOP/LIMIT and overtorque alarms will be suppressed.	
40058	0x0039	overtravel_annunciation_level_1	Configuration	overtravel_annunciation_level: Parameter set part 02 of 02 (Byte indexes 03 and 02).Type: FLOAT overtravel_annunciation_level is used in conjunction with overtravel_annunciation to set a zone at the ends of travel where STOP/LIMIT and overtorque alarms will be suppressed.	
40060	0x003B	drive_phasing	Configuration	Not applicable to the Group 57 actuator models.	1
40061	0x003C	maximum_travel_time	Configuration	Type: UNSIGNED_INTEGER(2) Maximum Travel Time: The time in seconds to travel the full span. Used for actuators with variable speed capability to extend the full span travel time to a desired value. This should not be more than 'Stall Time'.	
40062	0x003D	drive_gear_ratio_0	Configuration	drive_gear_ratio: Parameter set part 01 of 02 (Byte indexes 01 and 00).Type: FLOAT The gear ratio from the motor to the output shaft.	
40063	0x003E	drive_gear_ratio_1	Configuration	drive_gear_ratio: Parameter set part 02 of 02 (Byte indexes 03 and 02).Type: FLOAT The gear ratio from the motor to the output shaft.	
40064	0x003F	drive_motor_poles_0	Configuration	drive_motor_poles: Parameter set part 01 of 02 (Byte indexes 01 and 00).Type: FLOAT The number of magnetic poles on the rotor.	
40065	0x0040	drive_motor_poles_1	Configuration	drive_motor_poles: Parameter set part 02 of 02 (Byte indexes 03 and 02).Type: FLOAT The number of magnetic poles on the rotor.	
40069	0x0044	inch_per_rev_0	Configuration	Not applicable to the Group 57 actuator models.	1
40070	0x0045	inch_per_rev_1	Configuration	Not applicable to the Group 57 actuator models.	1
40071	0x0046	inch_per_rev_units	Configuration	Not applicable to the Group 57 actuator models.	1

*See page 99 for "Note" column description.

APPENDIX Modbus Parameter Maps

Holding Register Parameter Map (cont'd)

Holding Register Parameter Map					
Reg. No.	Hex Address	ID	Type	Description	Note*
40074	0x0049	EEPROM_SELECT	Configuration	Type: ENUMERATED The EEPROM memory selector utility function. EEPROM_SELECT=249 will reset the DCM. EEPROM_SELECT=252 will recall the default parameter values for the model. EEPROM_SELECT=253 will save the present parameter values to factory defaults. EEPROM_SELECT=509 will restore the factory defaults. All other values are ignored.	
40301	0x012C	BPU_STATUS_READONLY	Process	Type: UNSIGNED_INTEGER Register representation of the BPU Status discrete inputs BPU_STATUS (BPU Equipped Models Only).	2
40302	0x012D	BPU_OUTPUT_MILLIVOLTS_READONLY	Process	Type: UNSIGNED_INTEGER The output of the backup power unit as represented in DC millivolts (BPU Equipped Models Only).	2
40303	0x012E	MAIN_SUPPLY_MILLIVOLTS_READONLY	Process	Type: UNSIGNED_INTEGER The main supply voltage coming into the actuator as represented in DC millivolts (BPU Equipped Models Only).	2
40304	0x012F	BPU_LOP_MODE	Configuration	Type: ENUMERATED The action a BPU equipped actuator takes when the main supply voltage falls below the configured Loss of Power threshold (see BPU_LOP_DC threshold millivolts). Valid selections are: 0) Disabled; 1) Maintain Control with no alarm; 2) Maintain Control with LOP alarm; 3) Go to the LOP position and 4) Stay in Place (BPU Equipped Models Only).	2
40305	0x0130	BPU_LOP_GTP_PERCENT_0	Configuration	BPU_LOP_GTP_PERCENT: Parameter set part 01 of 02 (Byte indexes 01 and 00). Type: FLOAT The position percent of the full travel span that the actuator will move to if the BPU_LOP_MODE parameter is set to 'Go To Position' (BPU Equipped Models Only).	2
40306	0x0131	BPU_LOP_GTP_PERCENT_1	Configuration	BPU_LOP_GTP_PERCENT: Parameter set part 02 of 02 (Byte indexes 03 and 02). Type: FLOAT The position percent of the full travel span that the actuator will move to if the BPU_LOP_MODE parameter is set to 'Go To Position' (BPU Equipped Models Only).	2
40307	0x0132	BPU_LOP_DC_ALARMVOLTS_MILLIVOLTS	Configuration	Type: UNSIGNED_INTEGER The DC alarmvolts (expressed as millivolts) the voltage level the Loss of Power alarm will activate after the holdoff period (BPU Equipped Models Only).	2
40308	0x0133	BPU_LOP_ALARM_ALARMDELAY_MILLISECONDS	Configuration	Type: UNSIGNED_INTEGER The delay (expressed in milliseconds) before the Loss of Power alarm will activate after the main supply voltage was below the BPU_LOP_DC_ALARMVOLTS_MILLIVOLTS (BPU Equipped Models Only). See Serial Command "ALARMDELAY", page 71.	2
40309	0x0134	BPU_LOP_CPS_FAILURE_MODE	Configuration	Type: ENUMERATED This parameter defines the action a BPU equipped actuator takes when the main supply voltage falls below the configured Loss of Power threshold when the position sensor fails. Valid selections are: 0) Stay In Place; 1) Run Counterclockwise and 2) Run Clockwise (BPU Equipped Models Only).	2
40310	0x0135	BPU_CHARGE_PERCENT_READONLY	Process	Type: UNSIGNED_INTEGER The percentage of BPU charge based on the capacitor bus voltage. A capacitor bus voltage of 4.8V represents 0% charge and 9.1V represents 100% charge (BPU Equipped Models Only).	2

*See page 99 for "Note" column description.

APPENDIX *Optional Modbus TCP*

OVERVIEW

Modbus TCP is a version of the Modbus messaging protocol that is transmitted over standard Ethernet (TCP/IP) interfaces. Many control systems are migrating to Ethernet and TCP/IP to eliminate inflexible proprietary interfaces, boost communications performance, and reduce cost by leveraging existing infrastructure.

The Beck Modbus TCP Ethernet Communications Option provides a gateway to modern Ethernet-based control systems for the Group 57 actuator. It converts Modbus TCP Ethernet messages directly to RS-485 Modbus RTU messages which are transmitted directly to the actuator Digital Control Module (DCM). The option is powered by a Lantronix xPort device.

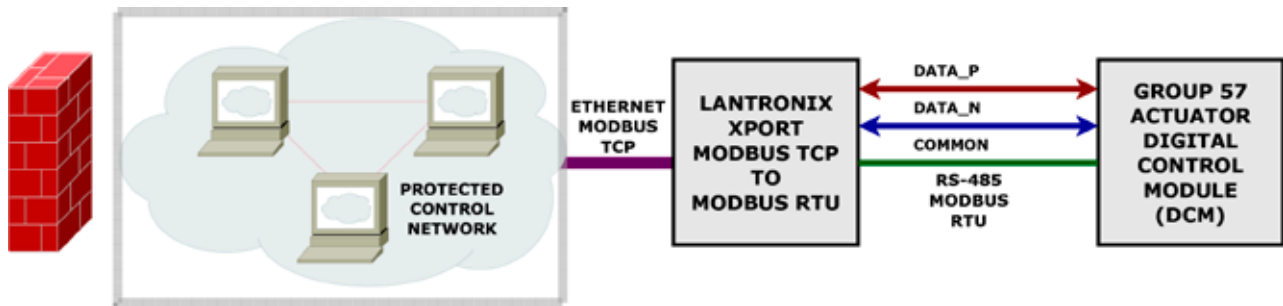

The Modbus TCP Ethernet Communications Option is available with all Group 57 actuators in two formats:

Modbus TCP Ethernet Terminal Block

This format has the Lantronix xPort device incorporated directly onto the terminal block.



**BECK MODBUS TCP DEVICE
INSTALLED ON THE TERMINAL BLOCK**

Field Retrofit Modbus TCP Ethernet Conduit Adapter

This format comes in a self-contained stainless steel conduit. One side of the conduit contains the RJ-45 Ethernet connector. The other side has wires that connect to the actuator terminal block.



BECK MODBUS TCP ADAPTER



INSTALLED BECK MODBUS TCP ADAPTER

APPENDIX *Optional Modbus TCP*

CONTROL INTERFACE OPTIONS

Modbus TCP Ethernet Terminal Block

The only connection with the original factory Modbus TCP Ethernet Terminal Block having the RJ-45 Ethernet jack on the side of the Lantronix xPort.



Group 57 actuators with this option are shipped pre-configured for Modbus TCP Ethernet communications using standard Modbus RTU defaults. Note that the default polling address is 246 (see page 108).

Modbus TCP Ethernet Conduit Adapter for Field Retrofit

The Modbus TCP Ethernet Conduit Adapter can be used to retrofit installed Group 57 actuators.

There are two versions of the Modbus TCP Ethernet Conduit Adapter for use with either AC or DC powered Group 57 models. The following table lists the appropriate adapter assembly number for each power type.

G57 POWER TYPE	ASSEMBLY NUMBER	ADAPTER VERSION
AC	20-2903-01	Modbus TCP to Modbus RTU adapter, 120 VAC to 240 VAC
DC	20-2903-02	Modbus TCP to Modbus RTU adapter, 22 VDC to 60 VDC

One end of the module has wires that are designed to be connected to a Group 57 terminal block. The function of the wires are to provide power to the module and connect to the actuator Modbus RTU interface.

For Assembly 20-2903-01 (AC Power Version), the wires are connected to the following terminals:

20-2903-01 WIRE COLOR	SIGNAL	TERMINAL
BLACK	AC LINE	1
WHITE	AC NEUTRAL	2
RED	MODBUS RTU DATA_P	33
BROWN	MODBUS RTU DATA_N	32
GREEN	MODBUS RTU COMMON	34

For Assembly 20-2903-02 (DC Power Version), the wires are connected to the following terminals:

20-2903-02 WIRE COLOR	SIGNAL	TERMINAL
GRAY (NON-POLARIZED)	DC PLUS	1
GRAY (NON-POLARIZED)	DC MINUS	2
RED	MODBUS RTU DATA_P	33
BROWN	MODBUS RTU DATA_N	32
GREEN	MODBUS RTU COMMON	34

The other end of the conduit module that faces away from the actuator has a standard RJ-45 Ethernet connector for the control network connection (see image at right).



Note that after the module is installed, the configuration of the Group 57 Modbus RTU interface may have to change, depending on control system requirements.

MODULE SETUP

Setup Overview



WARNING

This product is intended only for use on properly secured and firewall-protected industrial control system networks.

The Beck Modbus TCP module is based on the Lantronix xPort device. Lantronix recommended best practices for secure operation of this device should be reviewed prior to installation: <https://cdn.lantronix.com/wp-content/uploads/pdf/Best-Practices-for-IoT-Device-Security.pdf>.

The latest Lantronix security notices are available at: <https://www.lantronix.com/support/security-updates/>.

Configuration Password

According to the [xPort User Guide](#), Lantronix recommends that the user should always enable the enhanced password setting and create a strong, sixteen character password.

Some jurisdictions may require that a random password be set prior to actuator shipment. In this case, a printed copy of the password certificate will be shipped with the actuator.

Lantronix xPort Information

Additional documentation on the [Lantronix xPort](#) is available at: <http://www.lantronix.com>.

The xPort Modbus Protocol User Guide is available at: http://www.lantronix.com/wp-content/uploads/pdf/Modbus_Protocol_UG_Rev_J.pdf.

The xPort User guide is available at: https://cdn.lantronix.com/wp-content/uploads/pdf/XPort_UG.pdf.

Setup Overview

The Modbus TCP Ethernet Communications Module must be configured such that:

1. The Modbus RTU side of the module must match the Group 57 actuator configuration.
2. The Modbus Ethernet side of the module must match the control system network.

Standard Module Configuration Defaults

The following table lists standard configuration defaults for Beck Lantronix Modbus-TCP xPort-05 based products:

OPTION	DEFAULT VALUE
IP Address	STATIC IP: 192.168.100.64
Default Gateway	STATIC IP: 192.168.100.1
Netmask	255.255.255.0
Modbus RTU RS-485 Serial Interface	19200,8,E,1,RS485

Modbus RTU Polling Address

The Modbus TCP Ethernet Module default configuration is a pass-through gateway which transmits the underlying Modbus message without modification. Consequently, the polling address field in the message must match that of the target Group 57 actuator.

To simplify control system programming, it is recommended that the default Modbus RTU polling address of **246** be used in all Modbus TCP applications so that the same underlying messages can be used for all actuators in the network.

APPENDIX *Optional Modbus TCP*

Mandatory xPort Module Configuration Settings

Each xPort Modbus TCP Module is set at the factory to certain mandatory configuration settings with no changes required by the user.

The xPort module mandatory settings required for proper operation are:

- The serial interface MUST be set for “**RS485**”.
- The “Protocol” MUST be configured as “**Modbus/RTU, Server(s) attached**”.
- Pin CP1 MUST be configured as “**RS_485 Output Enable, non-inverted**”.

Modbus TCP Module Configuration Tools

The Lantronix Modbus-TCP xPort-05 is configured using free software and inexpensive hardware.

Hardware: USB-to-Ethernet Communications Adapter

A typical built-in PC Ethernet adapter is configured for the company network and will not be usable to communicate with the Modbus TCP Module. Inexpensive USB-to-Ethernet Communications Adapters can be used for this purpose.

The USB-to-Ethernet adapter settings under Windows should match the default settings of the Modbus TCP Module. It is recommended that the Windows device manager be used to set the interface to an address in the 192.168.100.XX/24 Subnet such as 192.168.100.20. *NOTE: The USB-to-Ethernet adapter must NOT use Address 192.168.100.64 as this is the default Modbus TCP Ethernet Module address.*

The following screenshot shows the IPV4 setup of a USB-to-Ethernet adapter set to address 192.168.100.20:

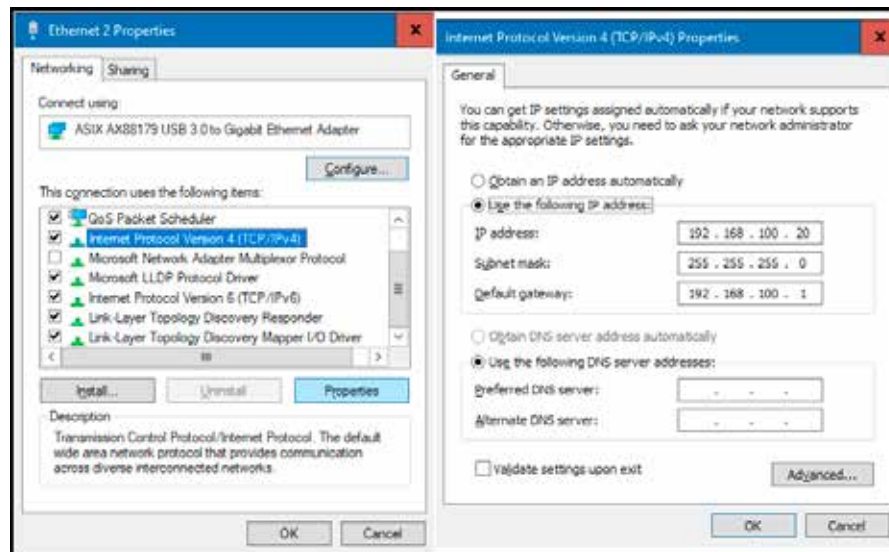

Software: Configuration Tools

There are two tools available for configuration of the Modbus TCP Ethernet Module, both of which are free:

- **Lantronix deviceInstaller Software:**

This is a free windows application from Lantronix which is available at: <https://www.lantronix.com/products/deviceinstaller/>

- **Telnet Command:**

The Telnet command is a standard command line utility provided by all operating systems. The standard Telnet port for the Lantronix xPort is 9999. For a Modbus TCP Ethernet Module at the default address, the correct Telnet command would be “**telnet 192.168.100.64 9999**”. *NOTE: The Telnet command may require additional user privileges under Windows.*

DCM Restoration of Modbus RTU RS-485 Serial Default Values

APPENDIX *Optional Wi-Fi*

Beck Group 57 actuators are available with an optional Wi-Fi interface that allows nonintrusive setup and configuration of the actuator. The optional Wi-Fi-equipped actuator may be used in conjunction with any Wi-Fi-capable device; such as a phone, tablet, or computer equipped with a web browser (Chrome, Edge, Firefox, Safari, etc.).



The optional Wi-Fi board is mounted on the back of the terminal board and connected to the DB9 connector on the DCM board (see below).

See Beck Group 57 Wi-Fi Instruction Supplement 80-5700-10 for details.



INDEX

Appendices	53–117	Modbus (RTU)	79–112
Application Reviews	119	Modbus Installation.....	79–80
Auxiliary Limit Switches	23	Modbus Interface Setup	81–83
Backup Power Unit (optional).....	73–78	Modbus Message Formats	93–98
Configuration/Calibration	21–39	Modbus Operation	84–90
Contactless Position Sensor.....	14	Modbus Parameter Maps	99–112
Demand Calibration	30	Modbus Troubleshooting	91–92
Demand Characterization Curves	32–33	Precautionary Information	79
Digital Control Module (DCM).....	14–20	Modbus (TCP)	113–116
Overview LEDs	18	Outline Dimension Drawings	7
Pushbutton Controls	19	Position Feedback Signal	34–35
Setup and Configuration Interfaces	17	Position Sensor	14, 45–46
Signal Test Points	20	Power Quality	11
Status Indication LEDs	19	Precautionary Information	8
Direction of Output Shaft Rotation	27	Product Demonstrations	119
Electronics	14–20	Restore Factory Settings	28
General Specifications	4–5	Safety Precautions	8
Handswitch (Lockable)	9, 47	Self-Locking Mechanism (SLM).....	40–42
Hand crank	9	Serial Commands	64–72
HART® Communication	53–59	Serial Communication	63
HART® Device Description Menu	53	Services	119
HART® Messages	60–62	Site Surveys	119
How to Obtain Service	119	Spare Parts, Recommended	48
Installation	10–12	Specification Writing	119
Electrical	11	Stall Protection	39
Mechanical	10	Start-up.....	12
Valves	10	Step Size	27–28
Wiring	12–13	Storage Information	8
Introduction	2	Table of Contents.....	3
Limit Switches (Over-travel)	22	Temperature Sensing	38
Loss of Demand Signal (LOS).....	31	Torque Sensing (Optional).....	36–38
Maintenance	40–48	Live/Historical Torque	36–37
DCM Board	44	Overtorque Alarm	38
DCM Board Fuse	44	Overtorque Protection	37
Handswitch	47	Travel (Degrees Rotation)	28–29
Lubrication/Gearing	40	Change Travel	29
Motor Assembly	40	Troubleshooting	49–52
O-Rings	47	Warranty Statement.....	119
Over-travel Limit & Auxiliary Switches	43	Wi-Fi (Optional)	117
Position Sensor	45–46		
Recommended Spare Parts	48		
Self-Locking Mechanism (SLM).....	40–42		

SERVICES

PRODUCT DEMONSTRATIONS

Each of Beck's Sales Engineers has access to a complete set of actuator models so that he can demonstrate virtually any of their features at your location. In order to arrange to see a Beck actuator in your plant or office, contact Beck's Sales Department.

SITE SURVEYS

Beck Sales Engineers are available to discuss your process control requirements. Often a visit to your location is the best way to gain a thorough understanding of your needs, in order to meet them most accurately and completely.

Mounting hardware, torque requirements, linkage, control signal information, and optional equipment can be analyzed most effectively at the work site. Beck's analysis at the job site can help ensure that specifications are accurate, especially in the case of complex applications.

APPLICATION REVIEWS

By sharing your needs with a Beck Sales Engineer you can take advantage of the best application advice for the type of control you need.

This review will yield a better understanding of the versatility of Beck actuators for your installations, as well as complete details on options and accessories to make the process as effective as possible.

SPECIFICATION WRITING

Beck provides specification writing assistance in order to help you specify and order the right actuators for your applications. Beck Sales Engineers will work with you to make it easier for you to obtain the proper equipment and give you confidence that no details are overlooked.

HOW TO OBTAIN SERVICE

Factory repair of actuators or subassemblies is available for both normal and emergency service. To assure prompt processing, contact the factory to receive a Returned Material Authorization (RMA) number. If a repair estimation is desired, please send the name and phone number of your contact for service authorization. It is helpful to include a description of the work desired with the shipment or, in the event of a problem, the malfunction being experienced.

THREE YEAR LIMITED WARRANTY STATEMENT*

Harold Beck & Sons, Inc. (Beck) warrants that our equipment shall conform to Beck's standard specifications. Beck warrants said equipment to be free from defects in materials and workmanship. This warranty applies to normal recommended use and service for three years from the date on which the equipment is shipped. Improper installation, misuse, improper maintenance, and normal wear and tear are not covered.

The Buyer must notify Beck of any warranty issues within 37 months of original shipment date and return the goods in question, at Buyer's expense, to Beck for evaluation. If the product fails to conform to the warranty, Beck's sole obligation and the Buyer's exclusive remedy will be: 1) the repair or replacement, without charge, at Beck's factory, of any defective equipment covered by this warranty, or 2) at Beck's option, a full refund of the purchase price. In no event will Beck's liability exceed the contract price for the goods claimed to be defective.

THIS WARRANTY IS EXPRESSLY IN LIEU OF ANY OTHER EXPRESS OR IMPLIED WARRANTY, INCLUDING IMPLIED WARRANTIES OF MERCHANTABILITY AND FITNESS FOR A PARTICULAR PURPOSE, AND ALL OTHER OBLIGATIONS OR LIABILITIES OF BECK. In no case shall Beck be liable for any special, incidental or consequential damages based upon breach of warranty, breach of contract, negligence, strict tort, or any other legal theory. Such damages include, but are not limited to, loss of profits, loss of revenue, loss of use of the equipment or any associated equipment, cost of capital, cost of any substitute equipment, facilities or service, downtime, the claims of third parties including customers and injury to property.

Buyer acknowledges its responsibilities under OSHA, related laws and regulations, and other safety laws, regulations, standards, practices or recommendations that are principally directed to the use of equipment in its operating environment. Buyer acknowledges that the conditions under which the equipment will be used, its use or combination with, or proximity to, other equipment, and other circumstances of the operation of such equipment are matters beyond Beck's control. **Buyer hereby agrees to indemnify Beck against all claims, damages, costs or liabilities (including but not limited to, attorney's fees and other legal expenses), whether on account of negligence or otherwise, except those claims based solely upon the negligence of Beck and those claims asserted by Beck's employees which arise out of or result from the operation or use of the equipment by Beck's employees.**

***Note: Internal water damage is not covered by warranty.**

A 100% EMPLOYEE OWNED COMPANY

BECK

~ founded 1936 ~

SINCE 2021



HAROLD BECK & SONS, INC.

11 TERRY DRIVE • NEWTOWN, PENNSYLVANIA 18940 • USA

PHONE: 215-968-4600 • FAX: 215-860-6383 • E-MAIL: sales@haroldbeck.com

www.haroldbeck.com

Made in USA

