



INSTRUCTION MANUAL



**This manual supports
Group 22 actuators
using DCM-2 part numbers:**

12-8224-41

12-8224-45

12-8224-51

12-8224-55



INTRODUCTION

This manual contains the information needed to install, operate, and maintain Beck Group 22 Actuators, manufactured by Harold Beck & Sons, Inc. of Newtown, Pennsylvania.

The Group 22 actuator is a powerful control package designed to provide precise position control of dampers and other devices requiring up to 8,000 lb-ft (10 846 N•m) of torque.

IMPORTANT: This manual contains information that will make installation simple, efficient, and trouble-free. Please read and understand the appropriate sections in this manual before attempting to install or operate your actuator.



The Group 22 actuator is an electric actuator for industrial process control. The actuator is ideal for use in large boiler applications, such as ID/FD fan dampers requiring precise, reliable control.

The Group 22 offers the excellent performance and maintenance-free design typical of Beck drives; plus the added flexibility and features provided by microprocessor-based electronics. Beck's full product line is shown below. Contact a Beck Sales Engineer for assistance with specific applications.



Group 11 rotary actuators provide precise position control of dampers, quarter-turn valves, fluid couplings, and other devices requiring up to 1,800 lb-ft (2 440 N•m) of torque.



Group 11 quarter-turn actuators are designed specifically for use with ball, plug, and butterfly valves. Direct-coupled, factory-mounted assemblies are available from Beck for easy installation.



Group 29 linear valve actuators are ideally suited for globe valves from 1" to 8" (25 mm to 203 mm) diameter. Beck's unique Tight-Seater™ coupling provides positive seating of valves.



Group 31 compact rotary actuators are particularly suited for coupling to ball, plug, and butterfly valves up to 4" (102 mm) diameter, and small dampers.

TABLE OF CONTENTS

Introduction	2
General Specifications	4
Outline Dimension Drawings	6
Precautionary Information	10
General Operation Information	11
Installation	12
Mechanical	12
Electrical	15
Wiring	16
Start-up	21
Electronics	22
Configuration/Calibration	26
Maintenance	42
Troubleshooting	49
Appendices	52
HART® Communication	52
HART® Messages	59
Serial Communication	62
Serial Commands	63
Index	70
Services	71

GENERAL SPECIFICATIONS

Output Torque, Stroke Time & Weight*								
Model	Output Torque lb-ft (N•m)		Stroke Timing (seconds/100°) Configurable			Weight lbs (kg)		
22-309	3,000 (4067)		30/300			515 (234)		
22-409	4,000 (5423)		15/300			515 (234)		
	2,500 (3387)		10/180					
	2,000 (2710)		08/150					
22-809	8,000 (10846)		15/300			1,250 (567)		
*Weight is dependent on selected options.								
Actuator Current Rating in Amps (listed by Supply Power Voltage)**								
Model	Supply Voltage (Volts AC)							
	1-phase		3-phase					
	120	240	208	240	380	416	480	575
22-309	6.0	3.0	3.5	3.0	1.9	1.7	1.5	1.3
22-409	n/a	n/a	4.0	3.5	2.2	2.0	1.7	1.4
22-809	n/a	n/a	6.9	6.0	3.8	3.5	3.0	2.5
**Operating voltage tolerance is +10% to -15%. All models may be operated at 60 Hz or 50 Hz frequency. The shaded current values depict the current rating for the standard operating voltage configuration. Non-standard, 3-phase operating voltages for the 22-309 and 22-409 are available with an optional transformer.								
Operating Conditions	-40° to 85°C (-40° to 185°F), 0 to 100% relative humidity, non-condensing							
Communication Interface	HART protocol Local Pushbutton / LED panel RS-232 Serial Commands							
Demand Input Signal Range	4–20 mA (ISA Type 4, Class U, Power Isolated) or 1–5 Volts DC (removal of input resistor on DCM-2 is required)							
Minimum Step Size	0.1° typical							
Hysteresis	0.25% of span at any point							
Demand input Signal Characterization	<p>Linear: Actuator output shaft moves proportionally to the input signal</p> <p>Square: Actuator output shaft moves proportionally to the square of the input signal</p> <p>Square Root: Actuator output shaft moves proportionally to the square root of the input signal</p> <p>Special Demand Curve: Actuator output shaft moves per the customer-defined Demand response curve</p>							
Position Feedback Signal	4–20 mA (ISA Type 4, Class U, Power Isolated)							
Isolation	Demand input and position Feedback signals are isolated from ground and the AC power line. Signal buffering provides 24 V dc isolation between the Demand and Feedback signals							

Action on Loss of Power	Stays in place
Action on Loss of Input Signal (Power On)	Stays in place or runs to any preset position (configurable)
Stall Protection	If the motor tries to run in one direction for more than 300 seconds (configurable from 30 to 450 seconds), the motor will shut off.
Overtorque Protection	The DCM-2 shuts off power to the motor if the measured output torque of the actuator exceeds 115% of the actuator rating (feature can be enabled/disabled).
Over-travel Protection Switches	Two SPDT switches (CW and CCW) provide over-travel protection. Standard switch setting is for 101° of travel.
Auxiliary Switches (Field Adjustable)	Two SPDT switches rated for 1 amp, 250 V ac.
Customer Wiring	Terminals accommodate up to 12 AWG (3.31 mm ²).
Handswitch	Permits local electrical operation, independent of Demand input signal.
Handwheel and Hand crank	Provides manual operation without electrical power (Hand crank mechanism is provided with model 22-809 only).
Motor	Does not coast or overshoot and will not overheat—even under continuous modulation. Motor overtemperature sensing is not provided by the actuator. Motor overtemperature sensing is not needed because Beck motors will not overheat.
Gear Train	High-efficiency, precision-cut, heat-treated alloy steel and ductile iron spur gears enclosed in (and permanently lubricated by) a grease-filled housing, are designed for long life and minimal wear.
Mechanical Stops	Prevent overtravel during automatic or manual operation.
Enclosure	Precision-machined, aluminum alloy castings painted with corrosion-resistant polyurethane paint provide a rugged, dust-tight, weatherproof enclosure. Type 4X, IP66.
Mounting Orientation	Upright, as depicted in the outline dimension drawings (pp. 6–8).
Standards***	C-UL US Listed; CE Compliant; UKCA Compliant
***NOTE: May not be available with all options and models. For more information, please call Beck at 215-968-4600.	

OUTLINE DIMENSION DRAWINGS

MODEL 22-309 & 22-409

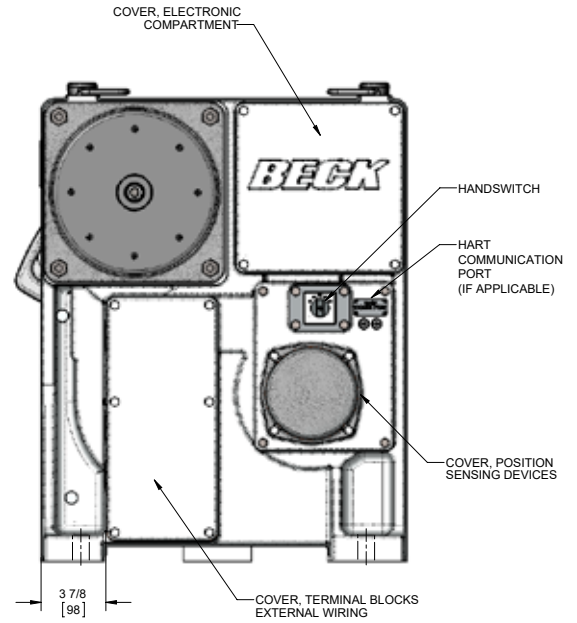
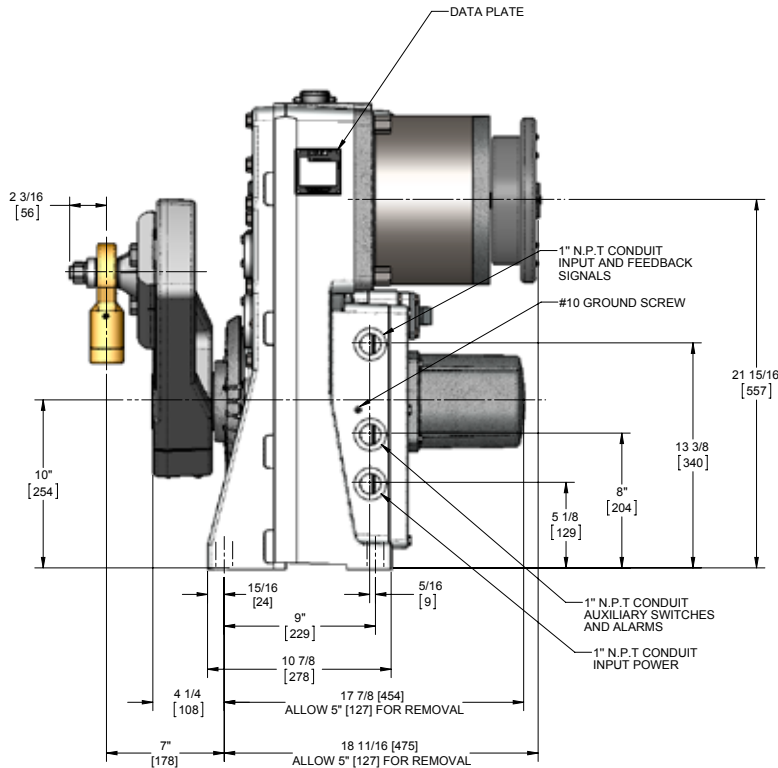

Mounting orientation should be upright for all models, as depicted

WITH OPTIONAL TRANSFORMER

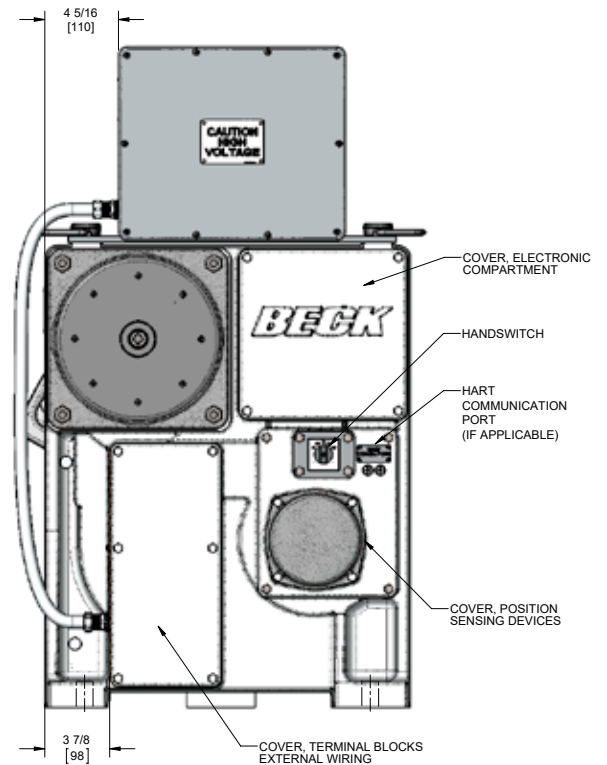
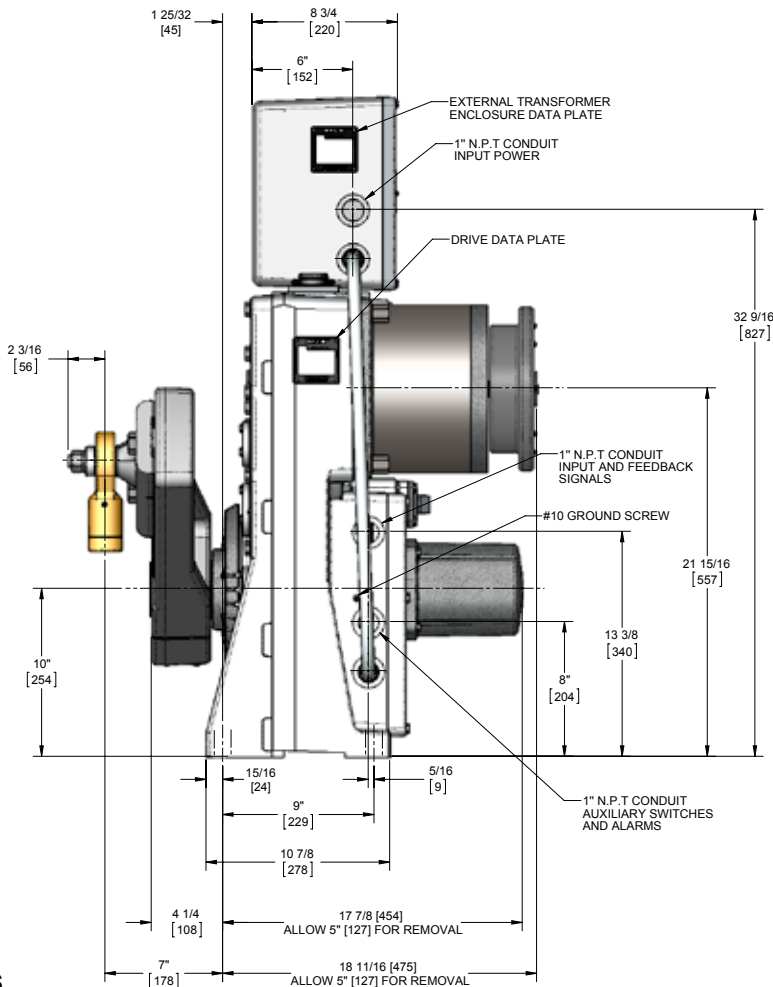

All Dimensions in Inches and [mm]

Model Number	Output Torque lb-ft [N·m]	Stroke Timing (seconds/100°) Configurable	Gear Ratio*	Net Weight lbs. [kg]	Output Shaft Diameter inches [mm]	Maximum Overhung Load lbs. [kg]
22-309	3,000 [4067]	30-300	250	540 [245]**	3-1/2 [89]	15,000 [6804]
22-409	4,000 [5423]	15-300	250	540 [245]*	3-1/2 [89]	15,000 [6804]
	2,500 [3387]	10-180	155			
	2,000 [2710]	08-150	123			

*If necessary, gear ratio may be set using Serial command "gearratio" (see page 65).

**660 lbs. [299] with optional transformer.

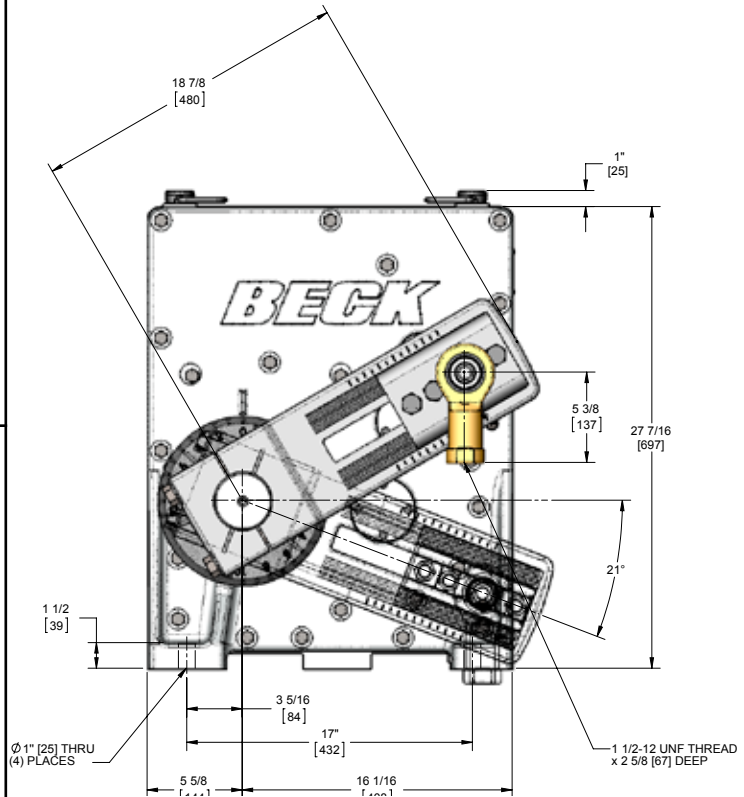
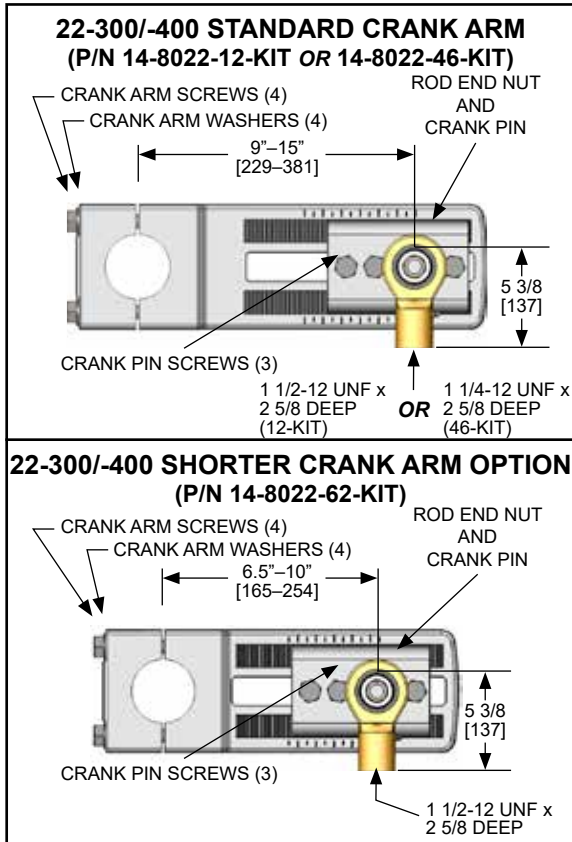

22-300/-400 CRANK ARM PARTS & FASTENER GUIDE

	Part Number	Quantity	Thread Size	Torque (lb-ft)[N·m]
Crank Arm Screw (Standard)	30-0308-13	4	3/4-16	420 [569]
Crank Arm Screw (Short, Option)	30-0308-76	4	3/4-16	420 [569]
Crank Arm Washer	30-0323-67	4	3/4	N/A
Rod End (14-8022-12-KIT)	12-2840-14	1	1 1/2-12	N/A
Rod End (14-8022-46-KIT)	12-2840-05	1	1 1/4-12	N/A
Rod End Lock Washer	30-0313-27	1	3/4	N/A
Rod End Nut	30-0319-23	1	3/4-16	200 [271]
Crank Pin	14-9885-31	1	3/4-16	N/A
Crank Pin Washer	11-7050-02	1	3/4	N/A
Crank Pin Screw	30-0307-30	3	3/4-16	300 [407]
Nut Plate	20-2641-08	1	3/4-16	N/A
Cover Screw	30-0308-98	14	5/16-18	10 [14]
Motor Mounting Nut	11-1271-10	4	1/2-13	37 [50]
Cover Screw, Optional Transformer	30-0329-70	10	10-32	3 [4]

OUTLINE DIMENSION DRAWINGS

MODEL 22-809

All Dimensions in Inches and [mm]

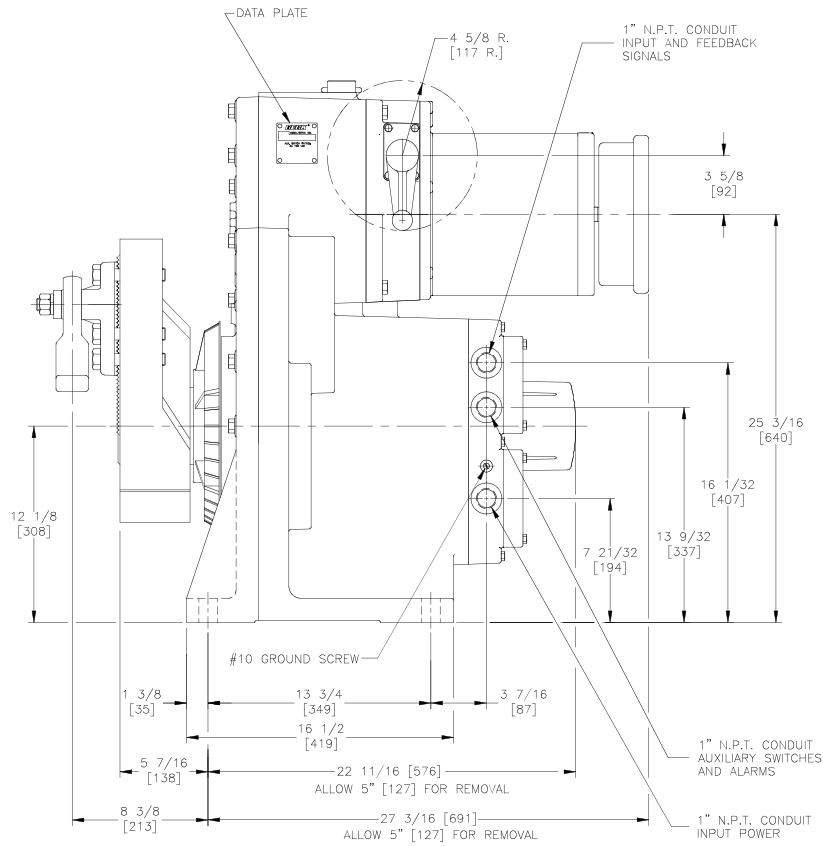

Mounting orientation should be upright for all models, as depicted

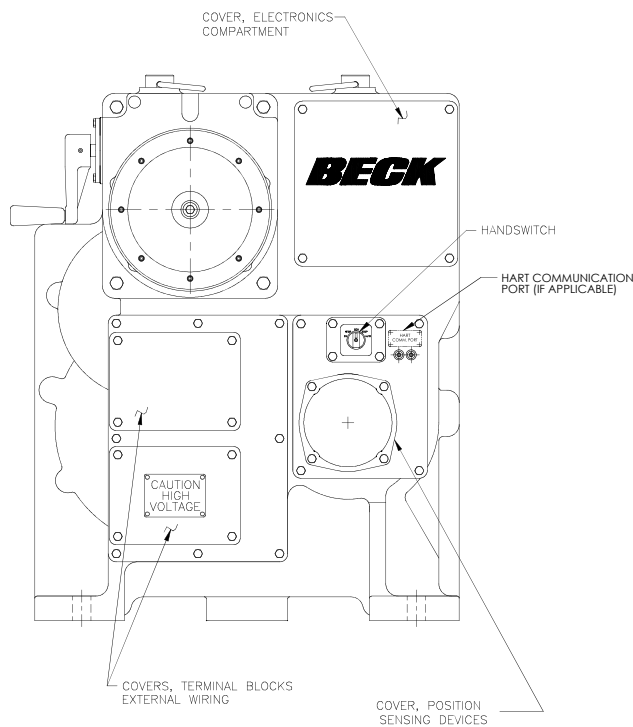

All Dimensions in Inches and [mm]

Model Number	Output Torque lb-ft [N•m]	Stroke Timing (seconds/100°) Configurable	Gear Ratio*	Net Weight lbs. [kg]	Output Shaft Diameter inches [mm]	Maximum Overhung Load lbs. [kg]
22-809	8,000 [10839]	15-300	250	1,250 [567]	4-3/4 [121]	30,000 [13608]

*If necessary, gear ratio may be set using Serial command "gearratio" (see page 65).

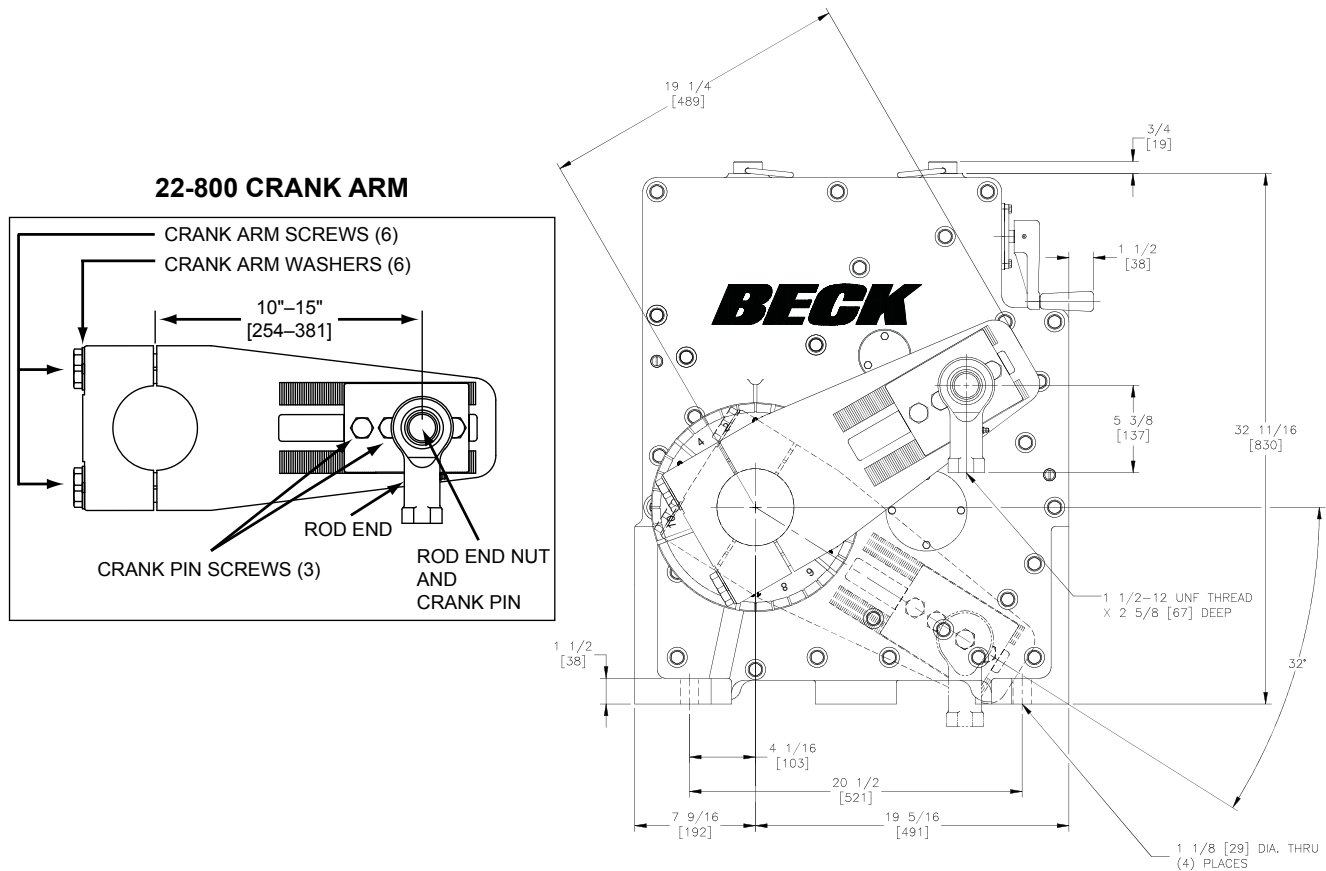

22-800 CRANK ARM PARTS & FASTENER GUIDE

	Part Number	Quantity	Thread Size	Torque (lb-ft)[N•m]
Crank Arm Screws	30-0308-76	6	3/4-16	420 [569]
Crank Arm Washer	30-0323-67	6	3/4	N/A
Rod End	12-2840-14	1	1 1/2-12	N/A
Rod End Lock Washer	30-0313-27	1	3/4	N/A
Rod End Nut	30-0319-23	1	3/4-16	200 [271]
Crank Pin	14-9885-31	1	3/4-16	N/A
Crank Pin Washer	11-7050-02	1	3/4	N/A
Crank Pin Screw	30-0328-49	3	3/4-16	420 [569]
Nut Plate	20-2641-08	1	3/4-16	N/A
Cover Screw	30-0308-98	16	5/16-18	10 [14]
Motor Mounting Nut	11-1271-10	4	1/2-13	50 [68]

PRECAUTIONARY INFORMATION

SAFETY PRECAUTIONS



WARNING

Installation and service instructions are for use by qualified personnel only. To avoid injury and electric shock, do not perform any servicing other than that contained in this manual. Please read and understand the appropriate sections in this manual before attempting to install or operate your actuator.

STORAGE INFORMATION

Beck actuators should be stored in a clean, dry area where the temperature is between -40° and 85°C (-40° to 185°F).

Group 22 actuators should be stored in an upright position and should not be stacked.

Damage due to moisture while in storage is not covered by warranty.

INSTALLATION—MECHANICAL

There are many considerations regarding proper mechanical installation—see the instructions beginning on page 12 for details. Refer to the outline dimension drawings for physical dimensions and required clearances.

INSTALLATION—ELECTRICAL

See the instructions beginning on page 16 for details regarding electrical installation.



CAUTION

For maximum safety, the Beck actuator body should be grounded. Use the green grounding screw in the wiring compartment of the actuator.



CAUTION

Always close covers immediately after installation or service to prevent moisture or other foreign matter from entering the actuator.

CONDUIT ENTRIES

Conduits are provided for power and signal wiring. Temporary plugs are installed in the conduit entrances at the factory for shipping only and are not intended for permanent use. Prior to actuator operation, all conduit entrances must be properly sealed in accordance with National Standards or Regulatory Authorities.

GENERAL OPERATION INFORMATION

MODES OF OPERATION

There are four basic modes of operation:

- **Handwheel / Hand crank**—local mechanical control
- **Handswitch**—local electrical control
- **Automatic**—remote electrical control
- **Override**—remote electrical control

Any or all of these modes can be used to test basic operation of your actuator during start-up.

HANDWHEEL / HAND CRANK

The Handwheel permits manual operation of the actuator without power. The Handwheel is coupled directly to the motor shaft at the rear of the motor housing and it rotates when the motor runs.

The Handwheel is particularly useful during initial installation or when power is not available. If power is available, the Handswitch must be moved to the STOP position before manually operating the Handwheel.

22-309/-409 HANDWHEEL



22-809 HANDWHEEL & HAND CRANK



HANDSWITCH

A Handswitch allows local electric control at the actuator. In either of the STOP positions, the motor is blocked from running. In the CW or CCW positions, the motor runs to move the output shaft in the corresponding direction. When moving the output shaft using the Handswitch, the motor will stop when the over-travel limit switches are reached.



The Demand signal can position the actuator only when the Handswitch is in the AUTO position.

AUTOMATIC

When the Handswitch is placed in the AUTO position, the actuator is in automatic mode and responds to a Demand signal (also called the setpoint). The Digital Control Module (DCM-2) compares the Demand signal with the output shaft position. When the DCM-2 detects a difference between Demand and Position (called error), the motor will rotate the output shaft until the Position matches the Demand.

OVERRIDE

Override operation can be used as a means of emergency operation or an alternate control method if 4-20 mA analog signalling is not available. PAT controls can be adapted by using external relays (solid state) to interface with the overrides.

Analog signal operation may be overridden by using relay logic input signals on the control override input terminals. CW (19), CCW (20), and STOP (21) terminals require connection to a common (COM) terminal (18) to perform the override as shown in the figure below.

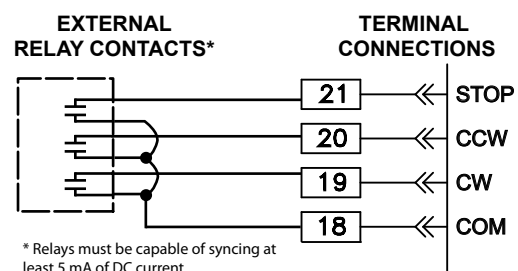

INSTALLATION MECHANICAL

DESIGN THE INSTALLATION

Select a suitable mounting location to allow:

1. Clearance to remove the actuator covers.
2. A mounting base height for easy access and full 360° crank arm rotation.
3. The linkage to move through its full travel without interference.
4. The actuator crank arm and damper lever arm to rotate in the same plane and the same direction.
5. The wiring conduits to be run from below the actuator to help prevent water entry.

MOUNTING THE ACTUATOR

Once the installation design has been planned, mount the actuator to the mounting base.

Beck Group 22 actuators must be installed feet down. If mounting near obstructions such as pipes or beams, take into consideration access to the field wiring terminals and the output shaft. Refer to the outline dimension drawings for the clearance necessary to remove covers.

Before the actuator is bolted into place, the mounting surface must be shimmed for flatness to within 0.020 inches. Each shim must support at least 75% of the mounting foot surface area (recommended shim size is 4 square inches or larger). Improper shimming or mounting can damage mounting feet.

If the actuator is to be bolted to a mounting plate, the plate must be rigid must not yield to the stresses created from operating the actuator. If the mounting plate is not rigid or the mounting bolts are not sufficiently tightened, damage to the actuator housing could result. A rigid, vibration-free surface will generally prolong the life of the actuator's components. The mounting plate should be at least as thick as the diameter of the mounting bolts.

Mounting bolts should be 7/8" for models 22-309 and 22-409, and 1" for model 22-809. The bolts should be hex head steel, zinc plated (HHSZP) Grade 5 or better. The bolts should be torqued appropriately for the application.

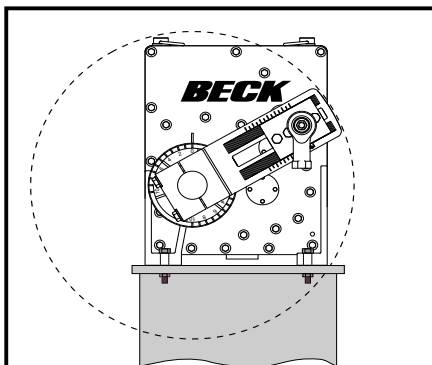

360° Crank Arm Rotation

LINKAGE REQUIREMENTS

For best results, the linkage should be designed in advance. In most applications, the best control will result when the linkage is adjusted so that the full 100° travel of the Beck actuator shaft is used, even though the driven lever may travel less than 100°. The general requirements for a good linkage are:

1. It must be rigid enough to carry the link thrust without bending or deforming.
2. It must have a built-in means of adjustment so that the length of the connecting link can be changed a small amount.
3. Rod end bearings, similar to those furnished on the Beck crank arm, should be used at both ends of the connecting link. This type of device permits small angular misalignments and helps prevent binding of the linkage.
4. The Beck crank arm radius must be calculated so that the arm will move through a 100° arc and the driven lever will move through its correct arc.
5. The actuator and driven shafts must be parallel and the linkage should be in a plane perpendicular to the shafts. See the example of a parallel linkage arrangement at right. Z-Linkage arrangements (where linkage ends are on opposite sides of the parallel between the driven shaft and actuator output shaft) are **not** recommended.

LINK-ASSIST™ REPORT

The Beck Link-Assist™ computer program optimizes the linkage configuration for the application load. It ensures proper setup and operation of the actuator. Contact your Beck Sales Engineer to take advantage of Beck's Link-Assist™ program. Additional Link-Assist™ information is available on the Beck website: www.haroldbeck.com.

PIPE LINKAGE KITS

Linkage Length "A"	Pipe Size	Minimum Pipe Nipple Length	Rod End Thread (UNF)	Linkage Kit Part No.	Length of 2 Linkage Ends (+/- 1.5" (38 mm))	Approximate Weight*
23.5"-40" (597-1 016 mm)	2" (51 mm)	2" (51 mm)	1-1/2"-12	20-1760-13	21.5" (546 mm)	28 lbs (13 kg)
37.75"-144" (959-3 658 mm)	3" (76 mm)	2.63" (67 mm)	1-1/2"-12	20-1760-10	35.13" (892 mm)	32 lbs (15 kg)
59.75"-144" (1 518-3 658 mm)	3" (76 mm)	2.63" (67 mm)	1-1/2"-12	20-1760-09**	57.13" (1 451 mm)	41 lbs (19 kg)
STAINLESS STEEL PIPE LINKAGE KITS						
23.5"-40" (597-1 016 mm)	2" (51 mm)	2" (51 mm)	1-1/2"-12	20-1760-43	21.5" (546 mm)	28 lbs (13 kg)
37.75"-144" (959-3 658 mm)	3" (76 mm)	2.63" (67 mm)	1-1/2"-12	20-1760-60	35.13" (892 mm)	32 lbs (15 kg)
59.75"-144" (1 518-3 658 mm)	3" (76 mm)	2.63" (67 mm)	1-1/2"-12	20-1760-59**	57.13" (1 451 mm)	41 lbs (19 kg)

Note: To calculate length of pipe required, subtract "Length of 2 Linkage Ends" from Linkage Length "A" (shown in diagram below).

* Does not include customer supplied pipe.

** Use when the angle between the linkage and the crank arm is less than 25°.

LINKAGE KITS AVAILABLE

Beck linkage kits are made to accommodate a wide variation in linkage lengths without requiring modification of end fittings.

Pipe linkage kits include the essential linkage end connections, rod end, studs, and jam nut hardware. Schedule 40 pipe is not included and

must be cut to length and threaded in the field (see table above, for instructions to calculate pipe length). To simplify installation of the pipe link, the kit accepts NPT right-hand threads on both ends of the pipe. Left-hand threads are internal to the linkage kit assembly, making final length adjustments quick and easy.

To order pipe linkage kits, first obtain the approximate overall linkage length "A" in the figure above. Select the kit part number from the table above. For lengths beyond those listed in the table, contact your Beck sales engineer.

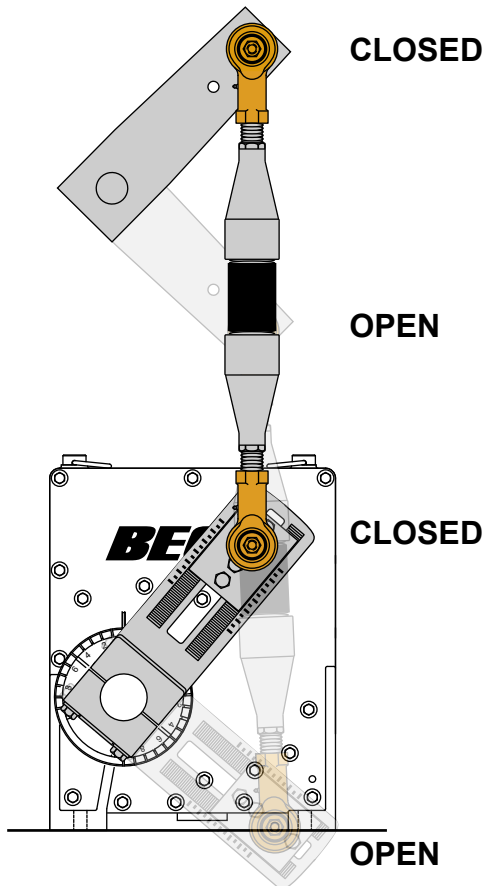

Parallel Linkage Design Example (Recommended)

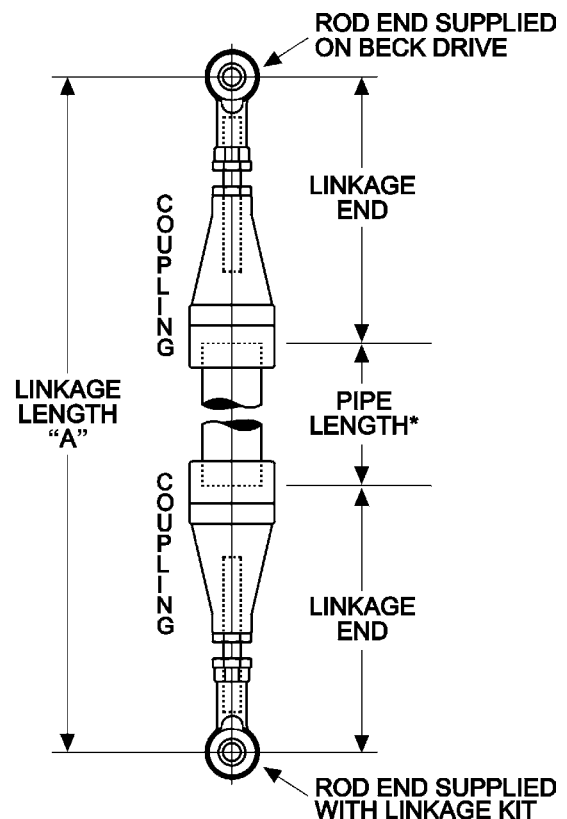

INSTALLATION MECHANICAL

LINKAGE INSTALLATION

The following procedure is recommended to couple the linkage between the Group 22 actuator and the driven shaft:

1. Position the driven shaft ① to the fully closed position.
2. Set the driven shaft lever to its required starting angle ② (predetermined with Link-Assist™).
3. Remove the rod end ③ from the Beck crank arm. Attach to the connecting link.
4. Adjust the connecting link ④ to the predetermined length.
5. Connect the connecting link to the driven lever at the predetermined radius ⑤.
6. Set the crank pin ⑥ on the Beck crank arm to the predetermined radius (see crank arm details on page 7 or 9 for acceptable ranges). This is done by loosening the crank pin screws ⑦ and sliding the crank pin to the predetermined position. Tighten the crank pin screws to the appropriate torque.
7. Loosen the crank arm clamping screws ⑧.



CAUTION

The crank arm will pop free, allowing adjustment for 360° around the shaft.

8. Position the actuator's output shaft ⑨ to its fully closed limit.
9. Swing the crank arm into position and assemble the connecting link to the crank arm crank pin. Tighten the rod end nut ⑥ to the appropriate torque (see page 7 or 9).
10. Tighten the crank arm screws ⑧ evenly, in a cross-pattern, to the appropriate torque (see page 7 or 9).
11. Lubricate the rod end bearings.

Carefully move the actuator's output shaft to the fully open (maximum input signal) position. Check that no binding occurs between the linkage, crank arm, driven shaft lever, and surrounding obstructions. Also observe that the driven shaft rotates the proper amount. Ensure that the actuator reaches the proper limit and shuts off.

If binding in the linkage occurs due to too much travel of the driven lever, travel can be reduced by shortening the Beck actuator crank arm radius. Return the actuator to the fully closed position. Loosen the crank arm crank pin screws, and the linkage stud-coupling lock nuts. To make fine length adjustments, while rotating the linkage move the crank pin to a shorter radius position.

LINKAGE INSTALLATION

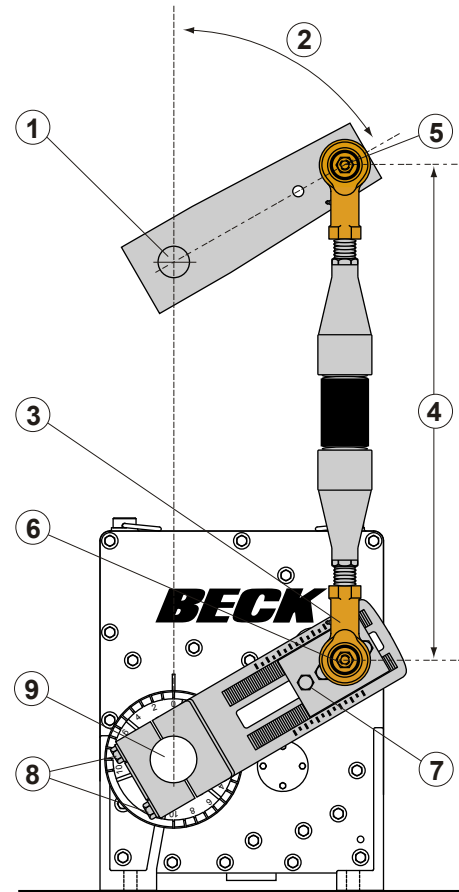

The crank pin may be adjusted in 1/4" (6.35 mm) increments on all Group 22 models.

To adjust the linkage length, it is preferable to use the stud couplings. The couplings have right-hand and left-hand threads, so it is not necessary to disconnect the ends to make a length adjustment. Be careful not to expose more than 7" (178 mm) of stud between the rod end and coupling.



CAUTION

The thread engagement depth in the couplings and rod ends must be greater than 1.25 x the thread diameter.

Tighten crank pin screws and linkage lock nuts, and once again, check operation to confirm that no binding occurs between the linkage and crank arm, driven lever arm, or surrounding obstructions. Further travel adjustments can be made by repeating the above steps.

Tighten all lock nuts and screws to the specified torque value (see pag 7 or 9).

Do not change limit switch settings to obtain desired valve or damper travel; this will adversely affect actuator operation.

INSTALLATION *ELECTRICAL*

POWER QUALITY

Power quality disturbances such as power outages, transient voltages, harmonic distortions, and electrical noise will adversely affect your actuator performance. Protecting your actuator from these conditions can reduce downtime and promote longer life for the equipment. Following the industry accepted standards below will help protect your actuator.

- ⚡ Select wiring materials according to the correct ampacity ratings dictated by national and local regulations.
- ⚡ Shielded, twisted pair cables can be used for signal connections to avoid being affected by electrical noise. These signal wires, based on Noise Susceptibility Level (NSL) per IEEE-518, fall into the level 1 classification. A braided shield will be more effective than a wrapped foil shield. Signal wire shields should be connected to the actuator casting grounding screw. If grounding at the signal source is required, then the shield should not be grounded at the actuator.
- ⚡ Raceways such as conduits and trays must be grounded at both ends to properly meet immunity requirements.
- ⚡ An AC power ground connection should be made between the power source and the Beck actuator. Grounding connections including wire and metal conduit are permitted, but the actuator-grounding conductor may not be connected to a structured metal frame of a building.
- ⚡ Surge suppression equipment that meets Underwriters Laboratory (UL) Standard 1449 may be used to protect against transient voltage conditions.
- ⚡ Power Conditioners may be used to regulate the supply voltage and maintain a constant voltage level. They are helpful in protection against voltage sags and swells, as well as some measure of electrical noise protection.
- ⚡ Harmonic filters may be used to minimize the effects of supply voltage waveform distortions and are used in applications that incur a large amount of high-frequency electronic noise.



CAUTION

Always close covers immediately after installation or service to prevent moisture or other foreign matter from entering the actuator.

ELECTRICAL INSTALLATION

Three 1" N.P.T. conduit connections are provided for power and signal wiring to the actuator. One conduit is provided for signal wiring connections and the other conduits are provided for power and auxiliary switch connections. Conduits should be routed from below the actuator so that condensation and other contaminants flow away from the conduit. All conduit entrances must be properly sealed in accordance with National Standards or Regulatory Authorities.

Power and signal wires should be routed to the actuator separately and be either shielded cables or installed in conductive conduit and/or cable trays.

Large, clearly labeled terminal blocks are enclosed in a gasketed compartment.

Refer to the wiring diagram furnished with your Beck actuator (fastened to the inside of the terminal block cover) for proper AC power and signal connections. It is advisable to provide normal short circuit protection on the AC power line.

For maximum safety, the Beck actuator body should be grounded. Separate ground terminals are provided in the wiring compartment for power and signal wiring. Wire size 12 AWG (3.31 mm²) is recommended for this purpose.

TERMINAL CONNECTIONS

The Group 22 terminal block assemblies have screw-down clamp terminals with separation barriers and nylon paper electrical shields (shields not shown on terminal connection diagrams). The terminals can accept a variety of lug types or a bare wire. Terminals will accommodate up to 12 AWG (3.31 mm²) wires, with the exception of the power terminals on the 22-809 (1, 2 & 3) and the power terminals included with the optional transformer enclosure on the 22-309/-409 (also terminals 1, 2 & 3), which will accommodate up to 10 AWG (5.26 mm²) wires.

TERMINAL SCREW TORQUES

Regardless of wire termination type, each terminal screw should be torqued to the proper specification upon landing your wire.

All input power terminal screws (terminals 1 to 3) on the model 22-309 and 22-409 should be tightened to 10 lb-in. The input power terminal screws on the model 22-809 and the optional transformer enclosure for 22-309 and 22-409 actuators should be tightened to 20 lb-in. All signal wiring terminal screws (terminals 4 to 21) on all Group 22 models should be tightened to 9 lb-in. Both the power and signal ground screws should be tightened to 20 lb-in.

INSTALLATION WIRING

SUPPLY POWER TERMINALS 1, 2, AND 3

Standard supply power for the model 22-309 is single-phase 120 Vac (refer to the actuator nameplate for specific rating). Input power connects line to terminal 1, neutral to terminal 2, and ground to the enclosure power ground screw. Terminal 3 is unused for 120 Vac operation.

Standard supply power for the model 22-409 is three-phase 208 Vac. Standard supply power for the model 22-809 is three-phase 480 Vac. Lines 1, 2, and 3 connect to terminals 1, 2, and 3 respectively on each of these drives. The ground wire should be connected to the enclosure power ground screw.

Alternate voltage options include single-phase 240 Vac for the model 22-309 and three-phase 208, 240, 380, 416, 480, & 575 Vac for all Group 22 models. The model 22-309 and 22-409 require an optional transformer enclosure to accommodate any non-standard voltage configuration.

Group 22 actuators are equipped with a transient protector assembly installed across each, or a combination of terminals 1, 2, and 3 (dependent upon your actuator model and configuration). Note: The transient protector assembly should not be removed.

AUXILIARY LIMIT SWITCHES TERMINALS 4 THROUGH 9

Group 22 actuators include two single pole double throw (SPDT) auxiliary limit switches rated for 1 Amp at 250 Vac. These switches may be useful for discrete position indication. The limit switches are actuated by adjustable cams on the control shaft (located with the position sensing device). Details on standard factory switch settings can be found in the configuration section of this manual.

AUTO MODE INDICATION TERMINALS 10 AND 11

A dry contact is available at terminals 10 and 11 to indicate when the handswitch is in the AUTO position. The switch contact is Form A; when the handswitch is not in the AUTO position, the contact is open and when the handswitch is in the AUTO position, the contact is closed. The contact is rated for 1 Amp at 250 Vac.



CAUTION

Always close covers immediately after installation or service to prevent moisture or other foreign matter from entering the actuator.

SYSTEM ALARM TERMINALS 12 AND 13

Indication of the system alarm is available as a dry contact at terminals 12 and 13. The factory standard is to open on alarm, but it may be reconfigured to close on alarm. Note that when power is lost, the contact opens. Reference the configuration section of the manual for additional details on how to change this functionality. The contact is rated for a maximum of 80 milliamps at 120 Vac/VDC.

DEMAND SIGNAL TERMINALS 14 AND 15

The DCM monitors an analog 4-20 milliamp input signal at terminals 14 (-) and 15 (+), and positions the output shaft position to match in response. The standard response is to follow the demand signal linearly.

FEEDBACK SIGNAL TERMINALS 16 AND 17

When feedback sourcing is enabled, the DCM-2 transmits a 4-20 milliamp position feedback signal on terminals 16 (-) and 17 (+) that is proportional to the actuator output shaft position.

CONTROL OVERRIDE INPUTS TERMINALS 18 THROUGH 21

Analog signal operation may be overridden by using discrete input signals on the control override input terminals. CW (19), CCW (20), and STOP (21) terminals require connection to a common (COM) terminal (18) to perform the override as shown in the table below.

Terminal Connections	Output Shaft Action
19 to 18	Clockwise Rotation
20 to 18	Counter-Clockwise Rotation
21 to 18	Stop in Current Position

The connection to terminal 18 is designed to be made through relay contacts or through a solid state switch capable of sinking at least 5 milliamps DC. When the circuit is open, terminals 19, 20, and 21 should measure +12 VDC with respect to terminal 18.



CAUTION

Do not connect an external voltage source to override terminals 18–21; an external voltage source may damage the DCM circuitry.

MODEL 22-309 & 22-409 TERMINAL CONNECTIONS

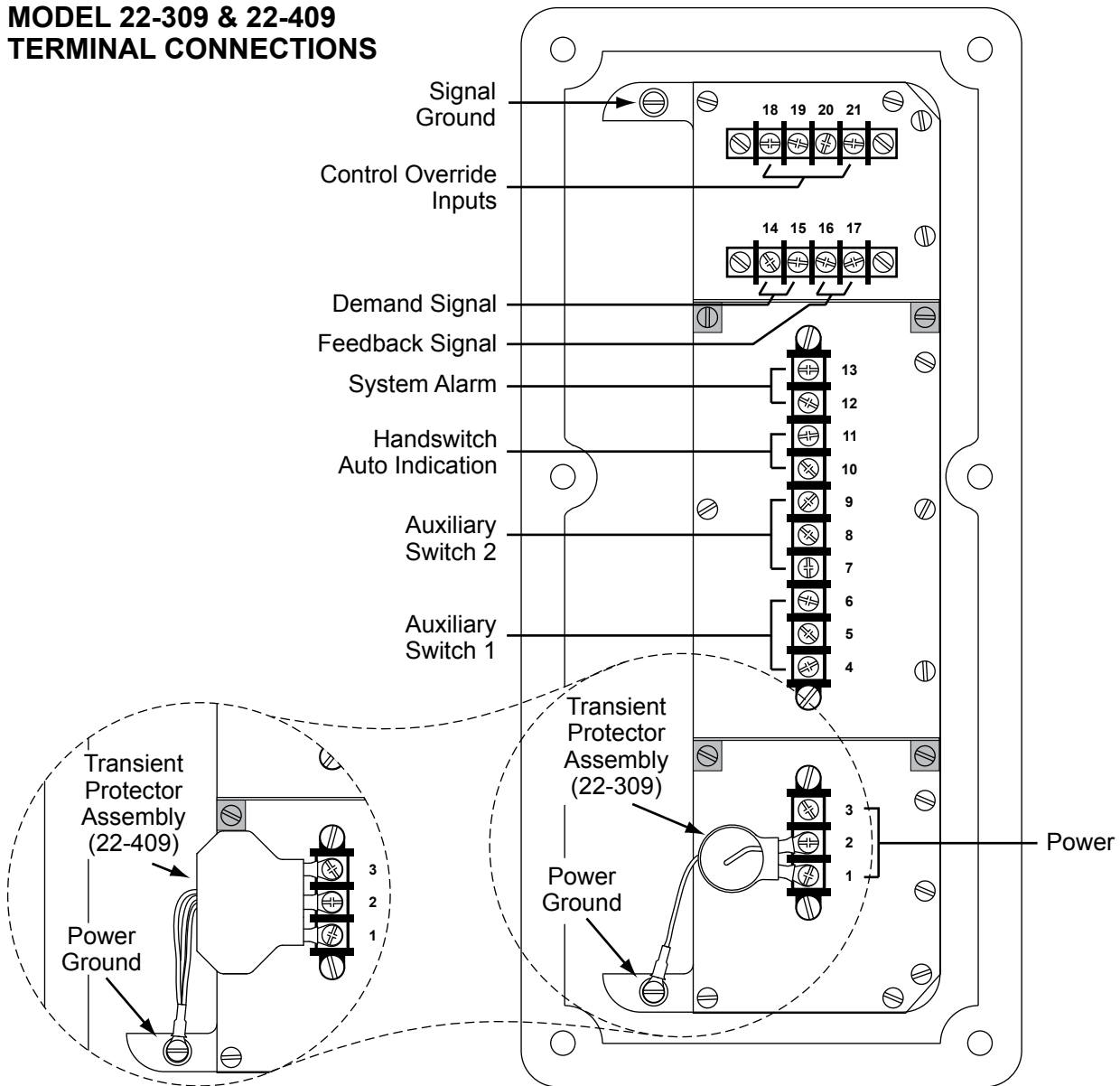

TRANSFORMER WIRING FOR 22-309/-409 OPTIONAL, ALTERNATE POWER SUPPLIES

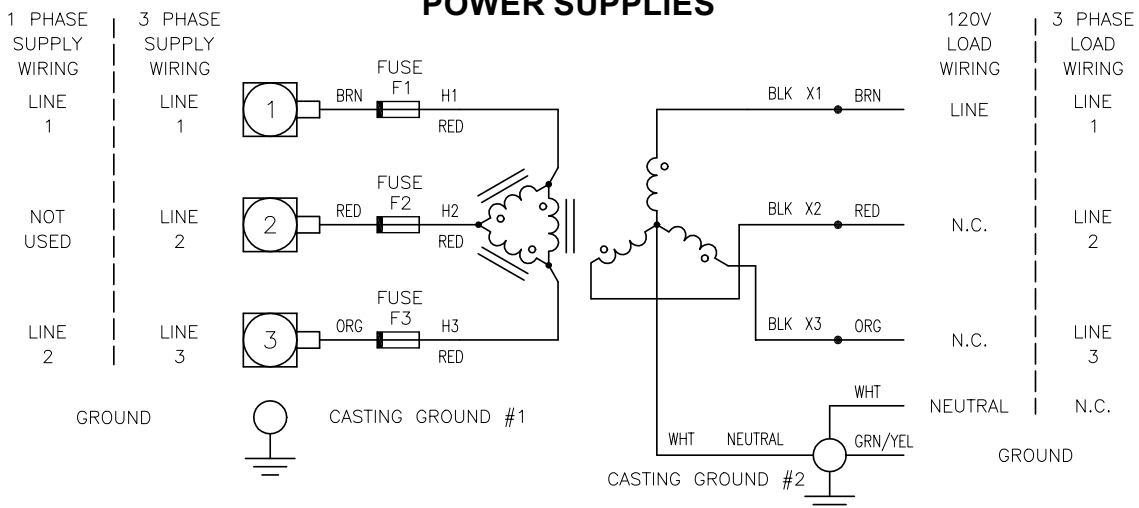

INSTALLATION WIRING

MODEL 22-309 & 22-409 TYPICAL WIRING SCHEMATIC

(a wiring schematic specific to each actuator is located under the wiring terminal cover)

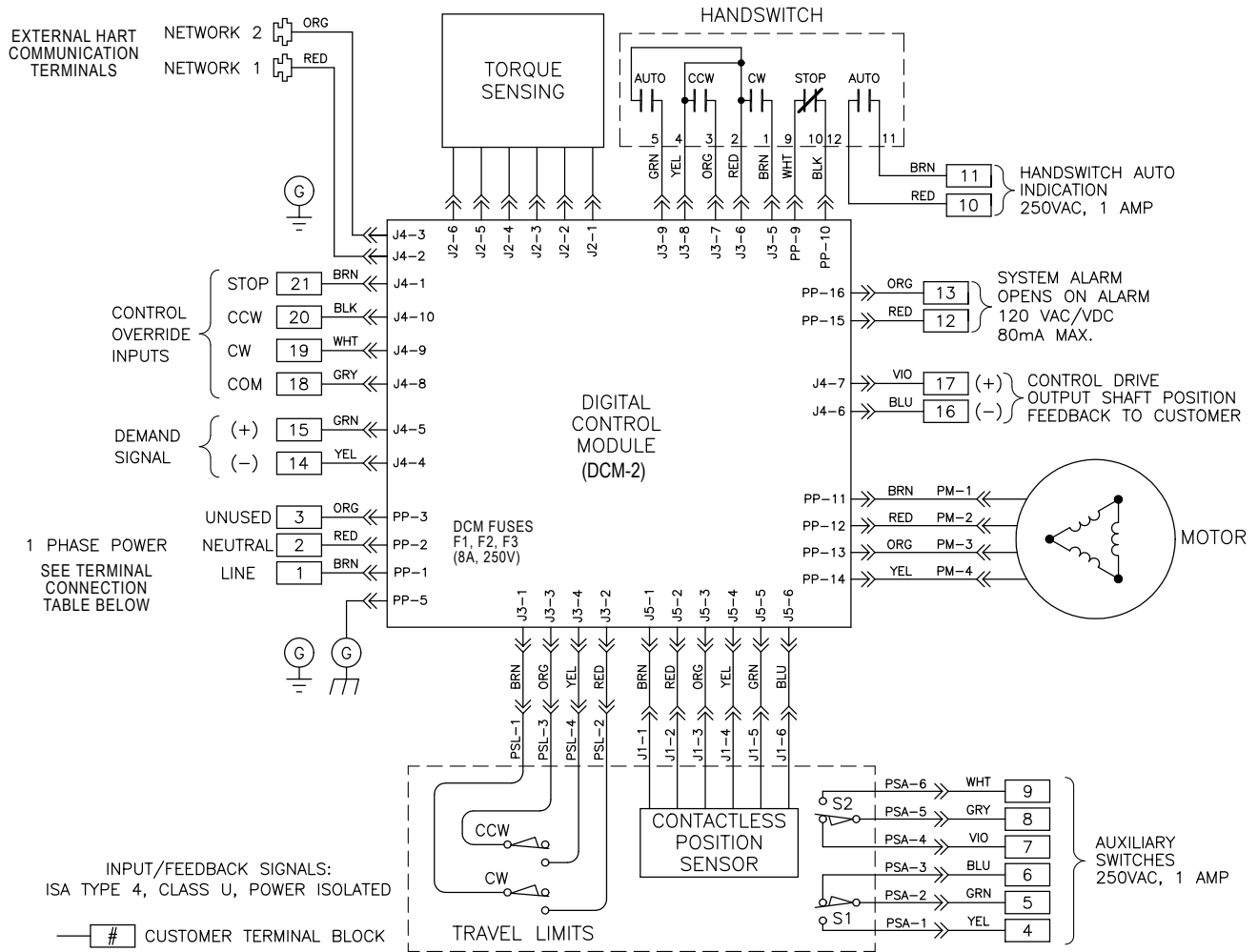

TERMINAL CONNECTION TABLE

	22-309	22-409
	Operating Voltage	
	Single-Phase	Three-Phase
	120 or 240 V ac* (refer to nameplate for rating)	208 V ac*
Terminal 1	Line	Line 1
Terminal 2	Neutral	Line 2
Terminal 3	Unused	Line 3

* Other operating voltages are available with an optional transformer.

† Fuse F3 is only applicable to model 22-409.

MODEL 22-809 TERMINAL CONNECTIONS

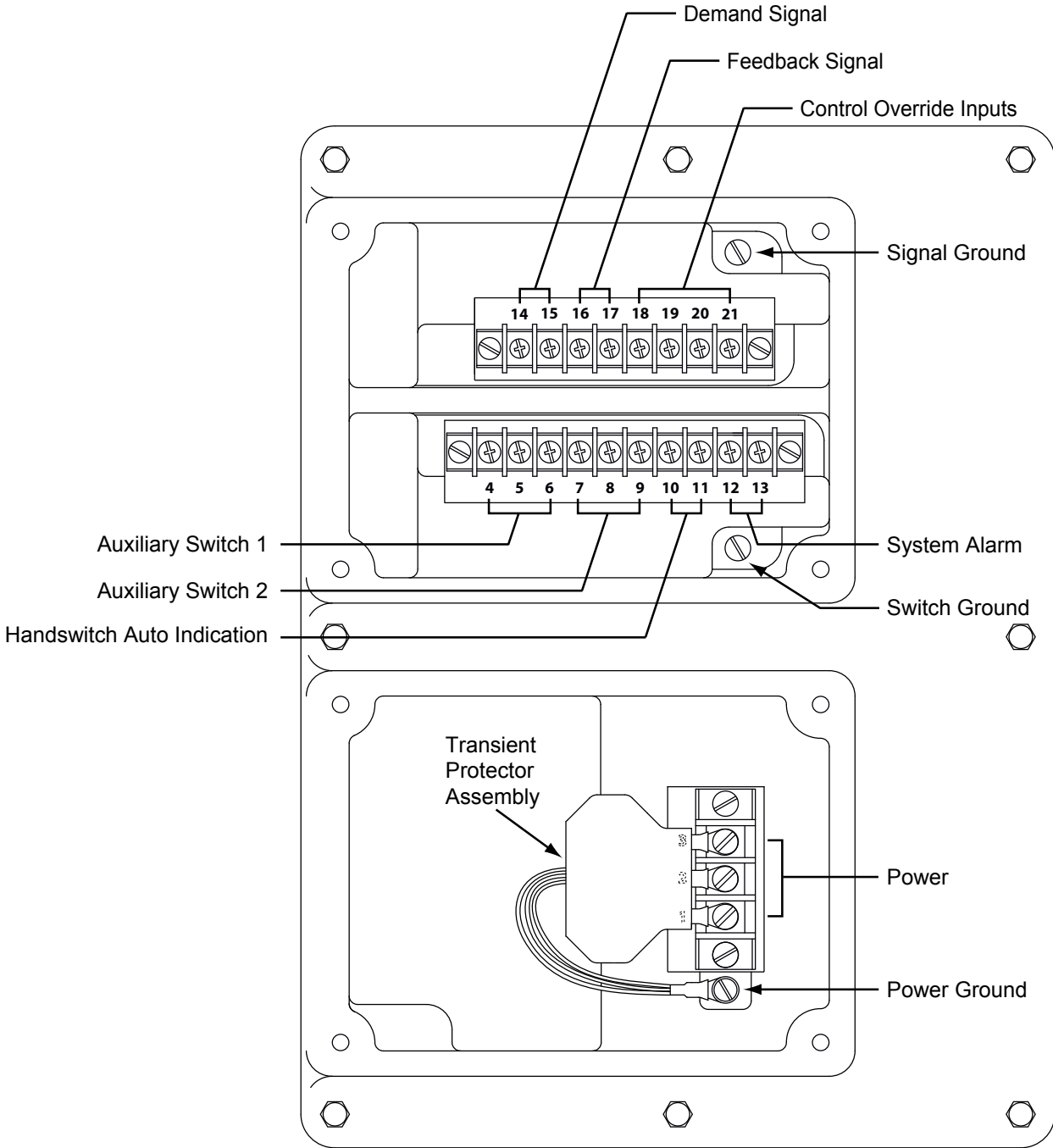

INSTALLATION WIRING

MODEL 22-809 TYPICAL WIRING SCHEMATIC

(a wiring schematic specific to each actuator is located under the wiring terminal cover)

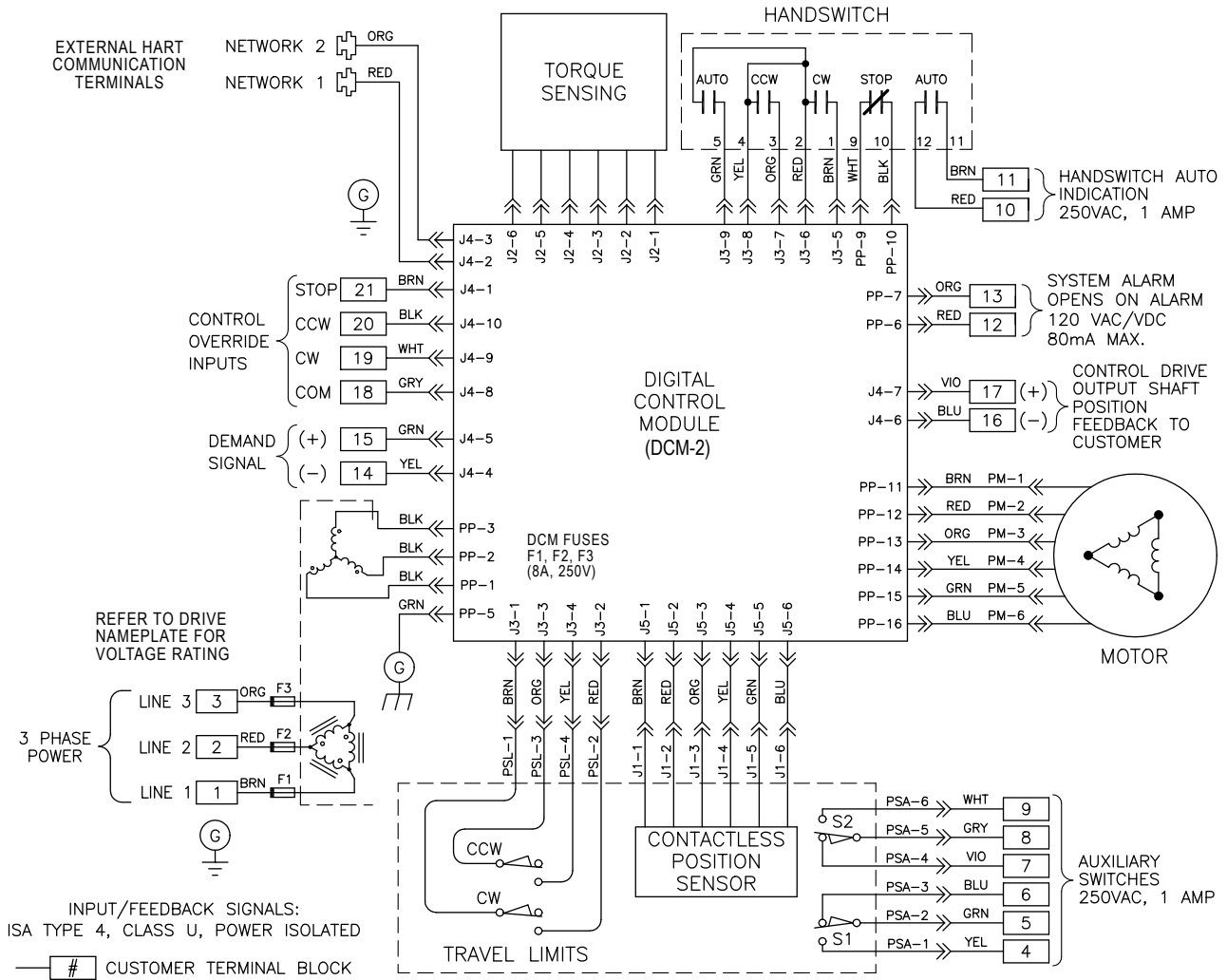

START-UP

NOTE: All Beck actuators are shipped from the factory ready for installation. Each actuator is set-up and calibrated to the customer's specifications that were written into the equipment order. Electrical adjustments are generally not required before placing the actuator in operation.

START-UP CHECKLIST

The following list provides some basic checks that should be performed before placing your actuator into operation.

- Inspect the location and the mounting bolts. Be sure the actuator is securely fastened to its mounting base.
- On the first start-up, place the Handswitch in a STOP position to ensure that no movement of the output shaft or linkage could potentially cause injuries.
- Confirm the actuator is receiving the appropriate operating voltage as shown on the nameplate.
- Check the DCM-2 Power LED. It should be pulsing (Dim/Bright) to indicate the board is active.
- Using the Handswitch, confirm the actuator moves fully to both the CW and CCW ends of travel.
- Confirm the actuator has a 4–20 mA Demand signal on terminals 14 and 15. Measuring 1–5 V dc across the same terminals also verifies the Demand signal.
- Place the Handswitch in AUTO and vary your control signal from 0% to 100%.
- Check for any of the status alarm LEDs on the DCM-2 local interface panel. If any LEDs are lit, refer to the Troubleshooting section of this manual for corrective action.
- Verify that the output shaft is moving to the desired 0% position with a 0% Demand signal and moving to the 100% position with a 100% Demand signal. If they are reversed, see the Configuration/Calibration section of this manual for instructions on how to change the direction of output shaft rotation.

ELECTRONICS

DIGITAL CONTROL MODULE (DCM-2)

The DCM-2 is a micro-processor based circuit board assembly that is mounted on an aluminum chassis and serves as the actuator's control center. The entire assembly is mounted in the actuator's DCM compartment (see photo at right).

The main function of the DCM-2 assembly is to be the actuator's positioner. The control board compares the Demand input signal to the actuator shaft position feedback signal from the Contactless Position Sensor (CPS-4) located in the control end compartment (see photo at right).

See the Troubleshooting section of this manual for details regarding fuse locations, test point locations, and expected test point voltage levels.

INTERFACES

The DCM-2 has three configuration interfaces: Pushbutton, HART and Serial Port.

PUSHBUTTON

The DCM-2 is equipped with a pushbutton panel that can be used to calibrate the Demand signal, configure Position, and also configure the direction of output shaft rotation for increasing Demand. These configurations and calibrations do not require any external equipment to perform. This interface also has LEDs for diagnostic information.

HART

The HART interface may be accessed by a HART handheld communicator or a HART equipped control system. All electronic calibration, configuration, and diagnostics can be accomplished through the HART interface. See the HART Appendix for details regarding connections.

SERIAL PORT

The serial port interface is accessible by connecting a computer to the DCM-2 using a Beck serial cable. All electronic calibration and configuration can be accomplished through the serial port interface. See the Serial Communication Appendix for details regarding connections.

The DCM-2 chassis assembly is mounted in a dedicated compartment (see photo) and normally does not need to be removed.

Accessing the DCM-2 assembly may be required for configuration or diagnostic purposes using either the pushbutton or serial port interfaces.

DCM
Compartment



Control End
Compartment

If the DCM-2 needs to be repaired for any reason, the whole chassis should be removed and replaced as an assembly. See the Maintenance section of this manual for complete details on chassis removal and installation.

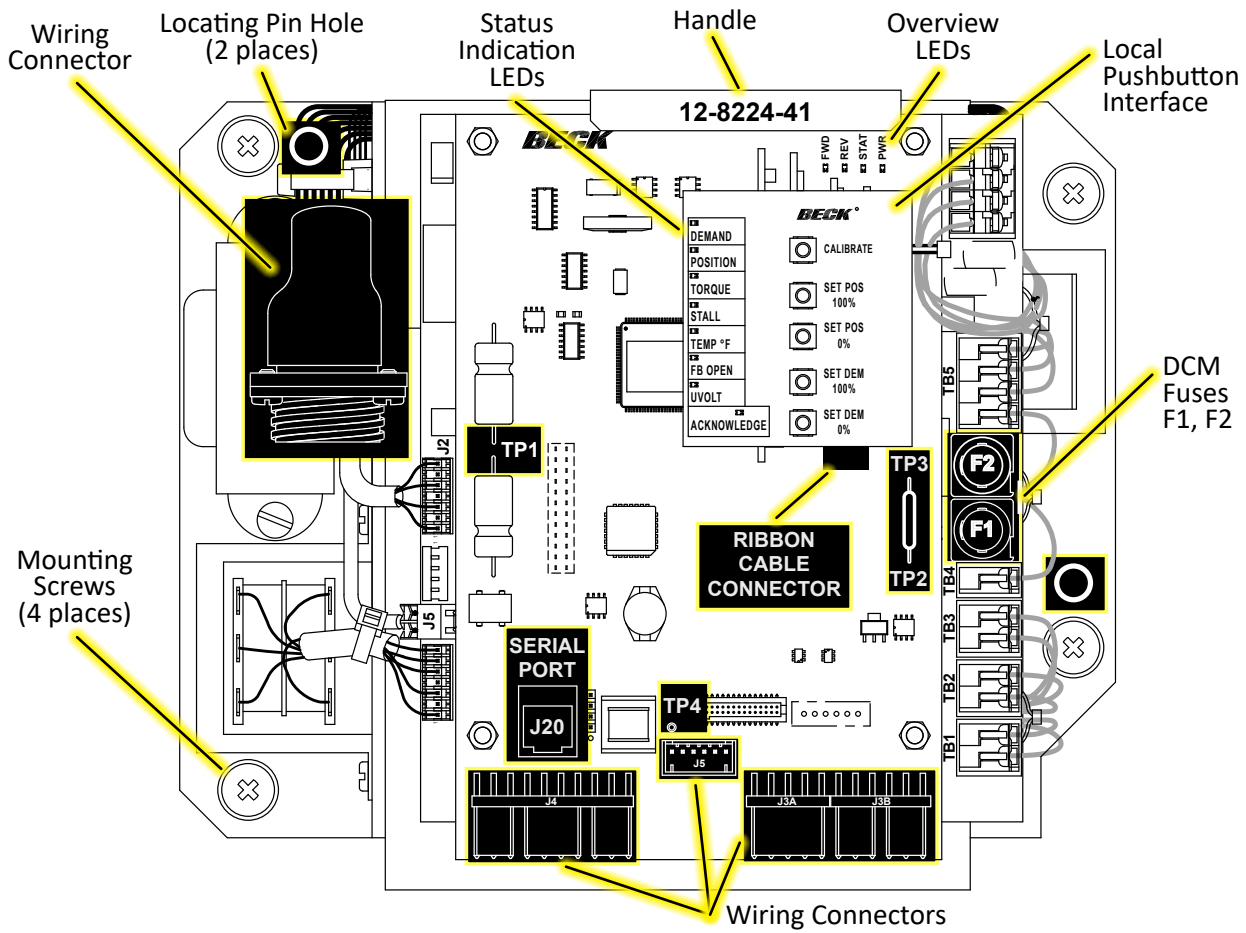

MODEL 22-309 DIGITAL CONTROL MODULE (P/N 12-8224-41)

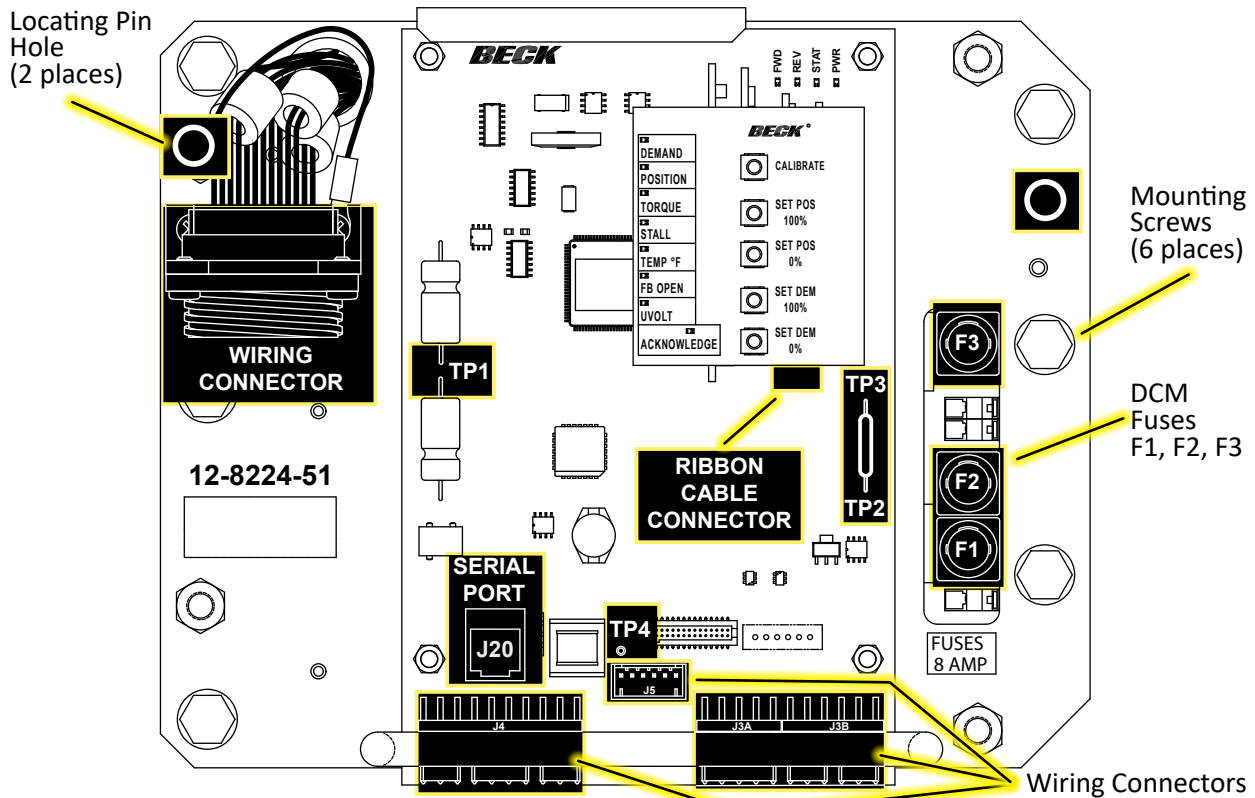

MODEL 22-409 & 22-809 DIGITAL CONTROL MODULE (P/N 12-8224-51)

ELECTRONICS

OVERVIEW LEDS

There are four LEDs in the upper right corner of the DCM-2 board. These LEDs indicate the basic status of the actuator.

FWD

This LED illuminates when the actuator is receiving a Demand signal greater than its position.

REV

This LED illuminates when the actuator is receiving a Demand signal less than its position.

STAT

This LED illuminates during a system alarm. Explanation of the specific alarm is available through the fieldbus or Serial interface. See the Troubleshooting section for additional information.

PWR

This LED illuminates when power is applied to the actuator. This LED pulses from bright to dim indicating the DCM-2 is operational.



OVERVIEW LEDS

STATUS INDICATION LEDS

When the "STAT" LED is lit, the applicable status indication LED(s) (pictured below) will light to reveal the condition(s) as described below. When the condition is corrected, the status will automatically reset. Indication of the alarm is also available at terminals 12 & 13.

DEMAND

Loss of the Demand signal (signal dropped below typical value of 3.2 mA).

POSITION

The Position signal to the DCM-2 is outside of the acceptable range of values (1.3–3.7 V dc).

TORQUE

This LED indicates that excessive thrust is present (over 105% of the actuator rating).

STALL

The actuator is in a stall condition and stall protection has been activated.

TEMP °F

Drive's internal temperature is outside of rating (-40° to 185°F (-40° to 85°C)).

FB OPEN

External position Feedback signal is enabled, but not wired to an external load or the wiring has failed between the actuator and the monitoring device.

UVOLT

Operating voltage is below the rated voltage tolerance.

ACKNOWLEDGE

Indicates when a calibration procedure has been completed.



STATUS INDICATION LEDS

PUSHBUTTON CONTROLS

PUSHBUTTON CONTROLS

The five pushbuttons (pictured below) on the DCM-2 customer interface panel are used for calibration. When pressing a pushbutton, pressure should be maintained until the “ACKNOWLEDGE” LED lights; this confirms receipt of the pushbutton command. See the Configuration/Calibration section of this manual for further explanation of calibration procedures.

CALIBRATE

This button must be pressed and held simultaneously with another pushbutton to perform a calibration.



CAUTION

Pressing the following buttons may change calibration and cause the actuator to reposition.

SET POS 100%

Press to designate the current position of the output shaft as the 100% position for actuator movement (this will correspond to a 100% Demand signal).

SET POS 0%

Press to designate the current position of the output shaft as the 0% position for actuator movement (this will correspond to a 0% Demand signal).

SET DEM 100%

Press to designate the current Demand input signal as 100% Demand.

SET DEM 0%

Press to designate the current Demand input signal as 0% Demand.

CONTROL END

The control end assembly is comprised of the Contactless Position Sensor (CPS-4), limit switches, and limit switch cams. The control end assembly is located in the actuator's control end compartment under the cylindrical cover.

The assembly is installed on the control shaft which is geared into the main output shaft of the actuator. As the output shaft turns it moves the control shaft, the limit switch cams, and the Contactless Position Sensor ferrite core.

The control end includes two SPDT auxiliary limit switches (labeled S1 and S2) for customer connection and two over-travel limit switches (labeled CW and CCW). The cams can be adjusted to actuate the auxiliary switches anywhere in the actuator's range of travel.

CONTACTLESS POSITION SENSOR (CPS-4)

The CPS-4 is a circuit board and sensor assembly that is part of the control end assembly. The CPS-4 provides the DCM-2 with a continuous position signal proportional to the position of the actuator's output shaft (see below).

The position sensing function of the CPS-4 is provided by a ferrite magnetic sensing element. An electronic circuit translates the voltage from the ferrite magnetic sensor into a position signal. The position signal is used by the DCM-2 to determine the actuator's output shaft position for control and to generate an analog 4-20 milliamp position feedback signal for external use.

CONTROL END / CPS-4

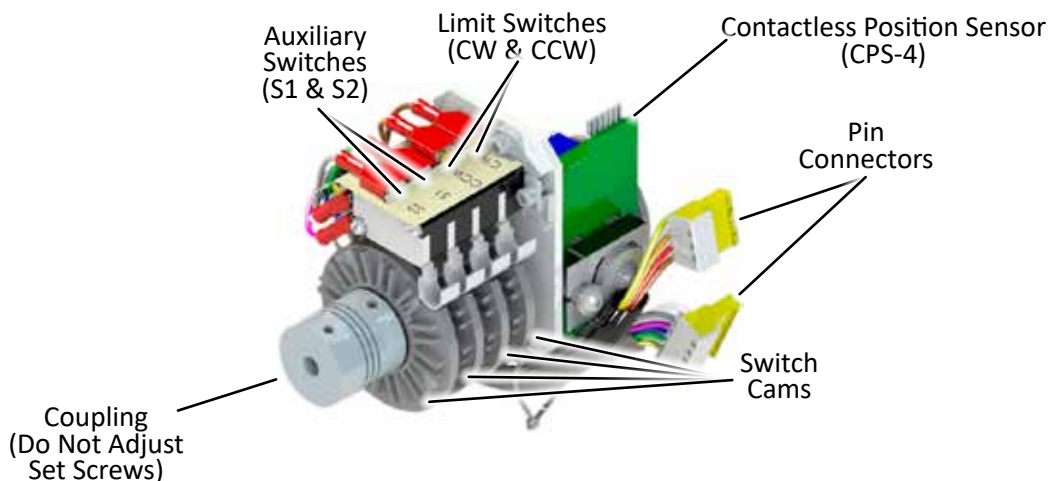

CONFIGURATION/CALIBRATION

NOTE: Your Beck actuator was shipped from the factory ready for installation; no electrical adjustments are required before placing it in operation. Each actuator is set up and calibrated to the specifications that were written into the equipment order.

Under normal operating conditions there is no need to recalibrate the actuator. However, if the application requirements change—or are different than specified on the equipment order—the actuator should be recalibrated according to the following procedures.

LIMIT SWITCHES

Actuators are shipped with over-travel limit switches factory-set for 101° of travel unless otherwise specified at time of order. Limit switches must be set inside the range of the built-in, non-adjustable mechanical stops (approx. 106° apart). Limit switches can be reset to limit over-travel of the output shaft when the actuator position calibration has been reduced (60° minimum). See the calibration procedure on page 30. Auxiliary switches are set as shown on the Standard Over-travel Limit and Auxiliary Switch Settings diagram on page 27 unless otherwise specified at time of order.

Switches are operated by cams which are clamped onto the control shaft. Setting a switch involves moving the output shaft to the desired position and positioning the cam so that it just operates the switch at that point. In the following procedure, the use of a continuity meter is recommended to determine when the switch opens or closes. If such a meter is not available, it is possible to hear the switch click as the contacts open and close.



CAUTION

Do not attach the meter or attempt to adjust the switch cams until the actuator is disconnected from the line voltage and auxiliary switches are disconnected from external power sources.

SETTING OVER-TRAVEL LIMIT SWITCHES CW AND CCW

This procedure should be used if the factory over-travel limit switch settings must be changed in the field. It is advisable to operate the actuator fully in each direction, using the Handswitch to check switch settings before attempting to change them. Follow the preceding instructions if they require adjustment:

1. Remove the control end cover and terminal block cover (1/2" bolt heads).
2. Move the output shaft to the CW or CCW limit.
3. Turn the Handswitch to the "STOP" position.
4. Use the Handwheel to position the output shaft at the desired over-travel limit.
5. **Disconnect power from the actuator.**
6. Connect a continuity meter across the appropriate pins of the J3 connector on the DCM-2 board (pins 1 & 2 for CW switch, pins 3 & 4 for the CCW switch). See illustration on next page.
7. While holding the shaft coupling stationary, rotate the appropriate cam using the 3/32" hex wrench in one of the cam adjustment slots (see illustration on page 25) until the meter shows continuity (switch contacts closed, switch clicks).
8. Use the Handwheel and confirm that the contacts are open in the normal operating range and closed at the desired over-travel limit.
9. Disconnect the meter and reconnect actuator power.
10. Repeat instructions for setting (and verifying) the opposite over-travel protection switch.
11. Replace covers and tighten cover bolts to 10 lb-ft [14 N•m] torque.

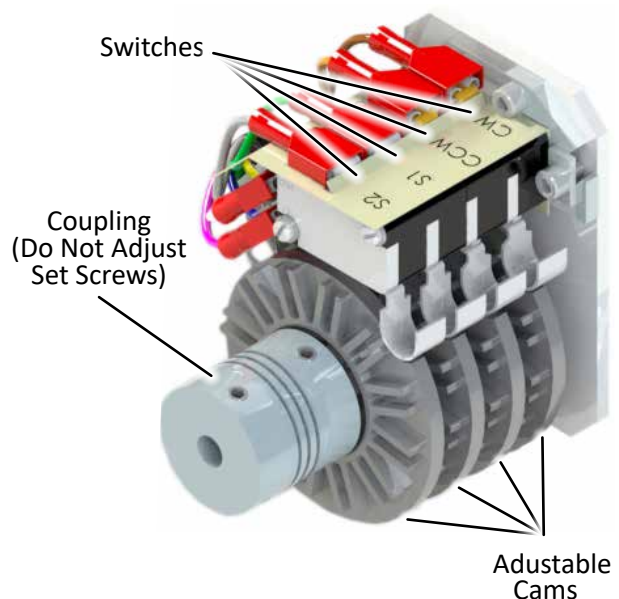

SETTING AUXILIARY LIMIT SWITCHES (S1 & S2)

Standard switch settings for the two auxiliary switches are shown on the diagram at right "Auxiliary Limit Switch Settings". The heavy line indicates a closed circuit. Follow these instructions to change the operating point of auxiliary switches:

NOTE: In the following procedure, it is assumed that switch settings are to be adjusted so that contacts are open when the desired position is achieved.

1. Remove the control end cover and the terminal block cover (1/2" wrench).
2. Move the output shaft to the desired switch trip position.
3. Turn the Handswitch to the "STOP" position.
4. **Disconnect power from the actuator and switch terminals.**
5. Connect the continuity meter across the appropriate terminals. See the actuator wiring diagram under the terminal block cover (or the diagram at right).
6. Rotate the appropriate cam using the 3/32" hex wrench in one of the cam adjustment slots (see CPS-4 illustration, page 26) until the meter shows continuity (switch contacts closed, switch clicks).
7. Disconnect the meter and reconnect power.
8. Move the actuator's output shaft in the desired direction to verify that the cam lobe moves away from the switch lever. If not correct, return to step 2 and reset the cam to the proper orientation.
9. Replace covers and tighten cover bolts to 10 lb-ft (14 N•m) torque.

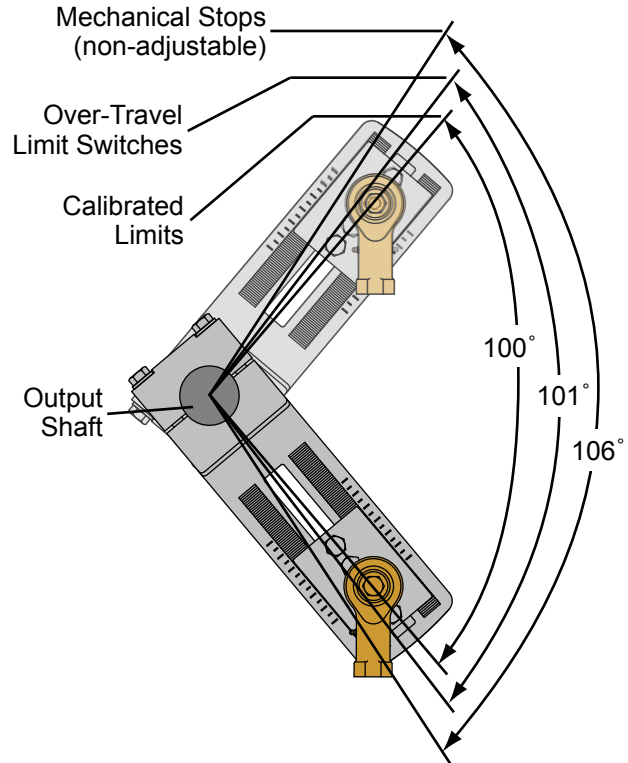

TRAVEL LIMITS

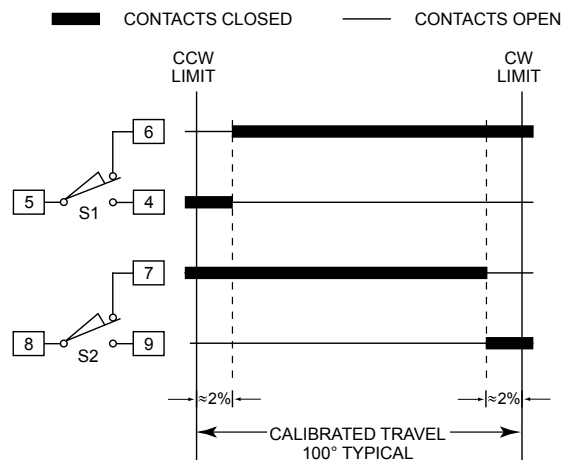

Note: The switch contacts are shown at midpoint of travel.

AUXILIARY LIMIT SWITCH SETTINGS

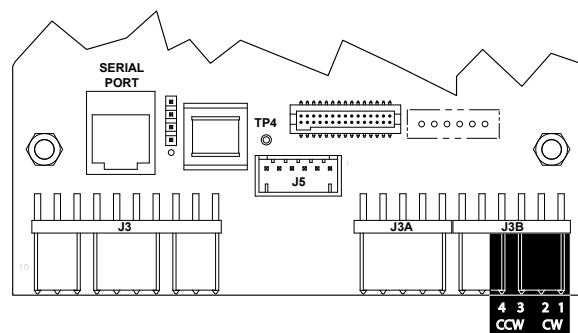

DCM-2 CONTROL BOARD CONNECTOR J3

CONFIGURATION/CALIBRATION

DIRECTION OF OUTPUT SHAFT ROTATION

Rotation direction refers to the direction the output shaft of the actuator rotates in response to an increasing Demand input signal. The rotation is either clockwise (CW) or counterclockwise (CCW) as shown in the figure below. The rotation of the driven load (e.g., damper lever arm) determines the actuator rotation suitable for an application.

Unless otherwise specified at the time of order, the output shaft is factory set to rotate clockwise in response to an increasing Demand signal. The direction of rotation can be changed using one of the following three methods. **NOTE:** After changing the output shaft rotation, adjust the output shaft travel index to reflect the correct 0% and 100% positions. Two set screws hold the travel index in place.

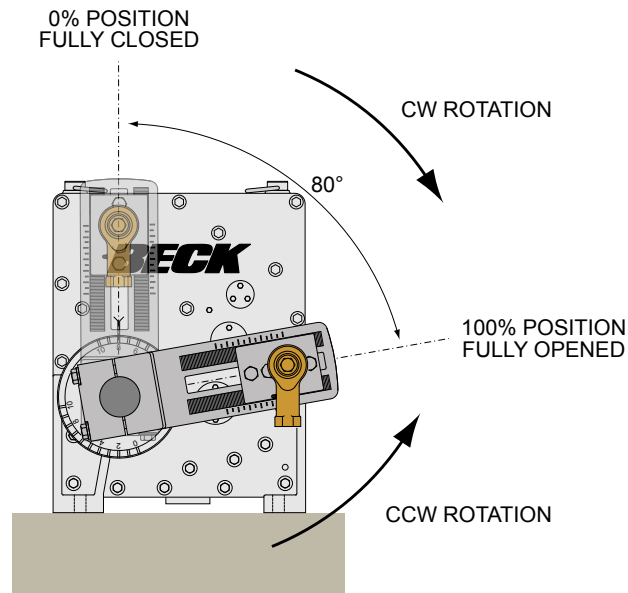

NOTE: The crank arm in the figure above may be adjusted to any start angle. The orientation and rotation shown here has been randomly selected for the purpose of this example.

PUSHBUTTONS method

1. Expose the DCM-2 by removing the four captive screws on the electronic compartment cover.
2. Position the actuator at the desired 0% position.
3. Press and hold the “CALIBRATE” pushbutton on the DCM-2 local interface panel, then press the “SET POS 100%” pushbutton until the “ACKNOWLEDGE” LED is lit.*

—OR—

2. Position the actuator at the desired 100% position.
3. Press and hold the “CALIBRATE” pushbutton on the DCM-2 local interface panel, then press the “SET POS 0%” pushbutton until the “ACKNOWLEDGE” LED is lit.*
4. Ensure the actuator operates as desired.
5. Replace the DCM-2 cover and tighten the cover bolts to 10 lb-ft (14 N•m) torque. Reset travel index.

* If the “ACKNOWLEDGE” LED does not light, but the “POSITION” LED does light, the change was not accepted by the DCM-2.

NOTE: When either of the above procedures is performed, both the 0% and 100% positions are automatically set.

HART method

Command: Drive Dir

DD Menu Location: MENU 4B

Functions>Configuration>General Setup

Selections:

CW Incr - select if the desired output shaft rotation is clockwise on increasing Demand signal.

CCW Incr - select if the desired output shaft rotation is counter-clockwise on increasing Demand signal.

Serial command method

Command: drvdir *n*

Arguments: *n*

0: CW - select if the desired output shaft rotation is clockwise on increasing Demand signal.

1: CCW - select if the desired output shaft rotation is counter-clockwise on increasing Demand signal.

STEP SIZE

Step size represents the minimum amount that the Demand signal must change to initiate a change in actuator position.

When the actuator is in AUTO mode, the DCM-2 runs the motor until the output shaft position matches the percentage of Demand signal. When they match, power is removed from the motor. The Demand signal must change by the step size before power is returned to the motor.

The step size is factory set to 0.15% of full travel span, unless otherwise specified at the time of order. The step size is adjustable from 0.1% to 2.5% when the actuator is configured for 100 degrees of travel. Adjustment is typically not required. The minimum step size regardless of travel is 0.1°.

It may be advantageous in certain applications where noise or other problems exist, to increase the step size slightly to prevent excessive modulation.

The step size can be changed using the following methods.

NOTE: Changing this parameter online could cause the actuator to reposition.

HART method

Command: StepSize

DD Menu Location: MENU 4B

Functions>Configuration>General Setup>

Enter the desired step size between "0.10%" and "2.50%".

Serial command method

Command: stepsize #.##

Arguments: #.## Desired step size (in degrees) of one incremental movement of output shaft travel. Acceptable range is between "0.10" and "2.50". May also be entered as a percentage of travel (rather than degrees) by adding the percent symbol when entering the stepsize (e.g., "0.10%").

RESTORE FACTORY SETTINGS

All DCM-2's are shipped from the factory configured per the customer instructions at the time of order. A complete copy of the factory configuration is stored on the DCM-2. You can revert to the factory settings at any time using one of the following methods.

NOTE: When the factory settings are restored, the Operation Mode (HART DD menu location 3E or Serial command "opmode") will not be changed for safety reasons. The operation mode should be set to "Follow" for normal automatic operation.

HART method

Command: Restore to Factory

Running this function will restore all configurable parameters to the original factory settings.

DD Menu Location: MENU 3C

Functions> Configuration

Serial command method

Command: restoremodes *n*

Arguments: *n*

1: Used as a safety measure, the number one must be entered as an argument to prevent someone from running the restoremodes command errantly.

CONFIGURATION/CALIBRATION

TRAVEL (DEGREES ROTATION)

Travel is defined as the number of degrees of rotation by the output shaft between the 0% and 100% positions.

Unless otherwise specified, the Group 22 actuator is set for the maximum of 100 degrees of rotation (between the mechanical stops that are cast into the body approx. 108 degrees apart).

It is recommended that the maximum travel be utilized to obtain full output torque of the actuator and maximum resolution of movement. The linkage can be arranged to utilize the maximum travel of the actuator when the driven load rotation is less than 100 degrees; for example 90 degrees of damper travel. A free Link-Assist analysis can be provided by a Beck sales or application engineer. Link-Assist Service information is available for review on the haroldbeck.com website.

Some exceptional applications may require less actuator travel. Travel calibration can be performed to reduce actuator travel. Travel less than 60 degrees is not recommended.

It is possible to change the full travel of the actuator output shaft if necessary. To change the Beck output shaft full range of rotation, electronic calibration changes can be made by using one of the two procedures below. These procedures can be performed by using the methods that follow.

- 0% and 100% Position Calibration:** Physically drive the actuator to the new 0% and 100% positions. Use the Pushbutton or HART method to set the new end points.
- Changing Travel in Degrees:** This allows the calibration to be changed without moving the actuator output shaft. Use the HART or Serial command method to set the desired full travel rotation in degrees (see p. 31). The 0% position will remain the same, but the 100% position will change to accommodate the new travel setting.

NOTE: In addition to recalibrating the electronics, the CW / CCW over-travel switches should also be adjusted to open just beyond the new electronic limits; this ensures that manual operation with the Handswitch will not cause over-travel or create a stall condition.

Calibrate the 0% and 100% positions:

PUSHBUTTONS method

1. Move the output shaft to the desired 0% position.
2. Press and hold the "CALIBRATE" pushbutton then press the "SET POS 0%" pushbutton until the "ACKNOWLEDGE" LED is lit.
3. Move the output shaft to the desired 100% position.
4. Press and hold the "CALIBRATE" pushbutton then press the "SET POS 100%" pushbutton until the "ACKNOWLEDGE" LED is lit.
5. Adjust over-travel limit switches as necessary to accommodate the new rotation.



SET
0%
POSITION



SET
100%
POSITION

HART method

Command: Set Pos 0%

Select when the output shaft is at the desired 0% position.

Command: Set Pos 100%

Select when the output shaft is at the desired 100% position.

DD Menu Location: MENU 4C

Functions>Configuration>PositionSensrSetup>

Change Travel Degrees:

HART method

Command: Travel

Enter the desired full stroke rotation in degrees.

HART DD Menu Location: MENU 4B

Functions>Configuration>General Setup>

Serial command method

Command: travel ###

Arguments: ### The desired full-stroke rotation in degrees.

CONFIGURATION/CALIBRATION

DEMAND CALIBRATION

DCM-2 boards are designed to accept a 4–20 mA (or 1–5 V dc) analog Demand signal. The input comes calibrated from the factory for the full range unless otherwise specified by the customer. It is not necessary to calibrate the Demand input when the actuator is installed; however, if the Demand needs to be calibrated to accommodate unusual operating conditions, two guidelines must be followed: First, the value for 0% must be greater than 0.5 mA and the value for 100% must be less than 21 mA. Second, the difference between 0% and 100% (minimum span) must be at least 4 mA. Use any of the following methods to calibrate Demand. Actuators may also be configured for split-range operation—contact the factory for details.

Calibrate the 0% and 100% Demand signal:

PUSHBUTTON method

1. Ensure the Handswitch is in the “STOP” position. This will prevent the actuator from repositioning during this procedure.
2. Apply the desired 0% Demand input signal to the actuator (e.g., 4 mA for 4–20 mA signal).
3. Press and hold the “CALIBRATE” pushbutton on the DCM-2 customer interface panel, then press the “SET DEM 0%” pushbutton until the “ACKNOWLEDGE” LED is lit.*
4. Apply the desired 100% Demand input signal to the actuator (e.g., 20 mA for 4–20 mA signal).
5. Press and hold the “CALIBRATE” pushbutton on the DCM-2 customer interface panel, then press the “SET DEM 100%” pushbutton until the “ACKNOWLEDGE” LED is lit.*
6. Turn the Handswitch to the “AUTO” position. NOTE: The actuator may reposition.
7. Run the actuator through its full operational range to ensure proper response to the Demand input signal.
8. Replace the compartment covers and tighten the cover bolts to 10 lb-ft (14 N•m) torque.

*If the “ACKNOWLEDGE” LED does not light, but the “Demand” LED does light, the calibration is out of acceptable range and was not accepted by the DCM-2. This is typically caused by trying to set 0% and 100% values too close together (i.e., less than 4 mA difference).



SET
0%
DEMAND



SET
100%
DEMAND

HART method

Command: DemRngLwr

Enter the desired 0% Demand signal ("4.00" to "16.00" mA).

Command: DemRngUpr

Enter the desired 100% Demand signal ("8.00" to "20.00" mA).

DD Menu Location: MENU 4D

Functions>Configuration>Demand Setup>

Serial command method

Command: dem0pctma

Arguments: ### Desired 0% Demand signal ("4.00" to "16.00" mA).

Command: dem100pctma

Arguments: ### the desired 100% Demand signal ("8.00" to "20.00" mA).

LOSS OF DEMAND SIGNAL (LOS)

The DCM-2 is capable of determining if the Demand input signal to the actuator is outside of an acceptable range. The DCM-2 uses a configurable loss of signal (LOS) threshold to determine if the Demand signal falls below a minimum value. Unless otherwise specified in the original order, the factory-set threshold is 3.2 mA. When the DCM-2 senses an LOS condition, an alarm condition will result, illuminating the "Demand" status indication LED. The actuator then responds according to the LOS setting.

The DCM-2 can be configured for one of two LOS actions:

1. **Stay in Place**—the actuator output shaft stays in place until the Demand signal returns to the acceptable range. This is the factory default.
2. **Go-to-Position**—the actuator output shaft will move to a preset position, designated in percentage of travel. For example, if the LOS action is set for 50%, the actuator output shaft will drive to the 12 mA position (based on a 4-20 mA span).

The LOS parameters can be configured using HART or Serial commands.



CAUTION

The following procedures could cause the actuator to reposition, which can adversely affect the process and cause potentially dangerous conditions.

Configure the LOS threshold:

HART method

Command: DemLimLwr

Enter "0.00" to "12.00" mA. Decimal value of the lower threshold for detecting LOS. (e.g., the typical value for a 4–20 mA system is "3.20").

DD Menu Location: MENU 4D

Functions>Configuration>Demand Setup>

Serial command method

Command: demlos ###

Arguments: ### Enter the desired Demand signal in mA below which LOS occurs (e.g., the typical value for a 4–20 mA system is "3.20").

Configure the LOS mode:

HART method

Command: LOS Mode

DD Menu Location: MENU 4D

Functions>Configuration>Demand Setup>

Selections:

Stay - select if the actuator should hold output shaft position when a loss of signal occurs.

Go-to-Pos - select if the output shaft should go to a specific position when a loss of signal condition occurs. Configure the position with LOS Pos.

Serial command method

Command: demlos *n*

Arguments: *n* Enter the desired mode

sip: (actuator will stay in place).

gtp: (actuator will go to position set in "demlogtp" command)

pat: (same as "sip", but suppresses the alarm).

Configure the LOS position when Go-to-Pos is selected:

HART method

Command: LOS Pos

Enter "-5.00%" to "105.00%". The percentage of full travel the actuator will move upon LOS.

DD Menu Location: MENU 4D

Functions>Configuration>Demand Setup>

Serial command method

Command: demlogtp ##.##

Arguments: ### Desired position of actuator if "gtp" is selected in "demlos". Position is expressed as a percentage of actuator travel (e.g., 50% = "50").

Command: demlogtp delay *n*

Arguments: *n* Time delay in seconds before the actuator will move to the position set in "demlogtp" (0 to 25.5 seconds). Default is "0".

Entering this command without an argument will return the present GTP and delay settings.

CONFIGURATION/CALIBRATION

DEMAND CHARACTERIZATION CURVES

The DCM-2 can be configured to interpret the applied Demand signal for linear or non-linear output shaft position response. Three predefined Demand signal response curves are available for use including: Linear, Square, and Square Root. A chart of each of these predefined responses is provided for your reference.

In addition to the three predefined characterizer curves, the DCM-2 also allows a custom user-defined curve to be configured. This option is called "Dem Curve Spcl".

The Demand characterization curve type can be configured with the following methods.

Change the Demand characterization curve:

HART method

Command: Dem Curve

DD Menu Location: MENU 4D

Functions>Configuration>Demand Setup

Selections:

Linear - select if the actual position % should match the applied Demand %.

Square Root - select if the actual position % should match the square root of the applied Demand %.*

Dem Curve Spcl - select if a user-defined response is desired (see characterization on the following page to define the desired response curve).

Square - select if the actual position % should match the square of the applied Demand %.

Serial command method

Command: demfunc *n*

Arguments: *n* Enter the integer that represents the desired Demand signal response as follows:

0: Linear - select if the actual position % should match the applied Demand %.

1: Square Root - select if the actual position % should match the square root of the applied Demand %.

4: Special Curve - select if a user-defined response is desired (see characterization on the following page to set the desired response curve).

5: Square - select if the actual position % should match the square of the applied Demand % (e.g., "demfunc 0" sets the actuator to a linear Demand response).

DEMAND SIGNAL RESPONSE CURVES

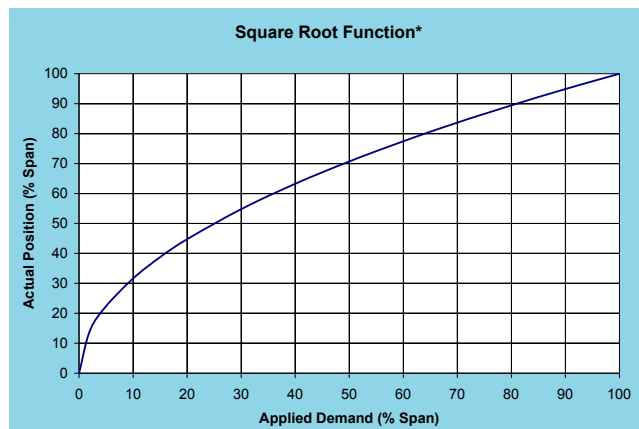
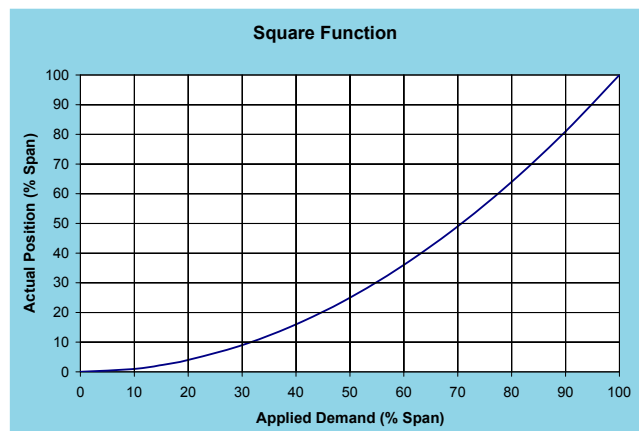
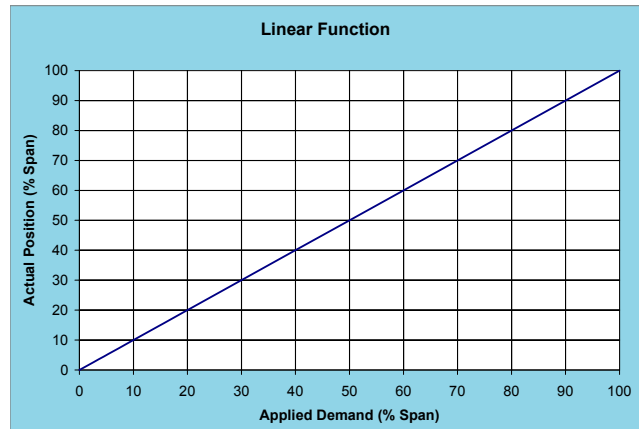

***NOTE**

Implementing a square root characterization creates extremely high gain when the Demand signal is below 10%; this causes instability and is unsuitable for control at this level. Do not apply this curve if the control loop may need to modulate at the lower range of travel.

USER-DEFINED CHARACTERIZATION

Special curves may be created from up to 20 segments, each of which has a node for a starting point and a node for an ending point. All 20 segments do not have to be used, but the used segments must be grouped together starting with segment 1. Segments cannot be skipped.

A node is a coordinate comprised of an X,Y point. When defining nodes, X-values and Y-values must increase as the node number increases. For example, the X-value and Y-value of node 2 must be higher than the X-value and Y-value of node 1. Nodes cannot be skipped. Always start at node 1.

Unless otherwise specified, the Special curve ships from the factory defined as a linear function (i.e., one segment beginning with node 1 at X = 0%, Y = 0% and ending with node 2 at X = 100%, Y = 100%). X-values are typically chosen to give a reasonable spacing in Y-values. Y-values are calculated from X-values using the desired formula, or are chosen from X-values picked from a table of data.

The customer may specify a custom characterization by entering X- and Y-value pairs to define line segments between 0% and 100%.

The example table shown at right describes the X and Y values used to approximate a square function. The result of this example is shown in the accompanying graph. In this case, the Y coordinate of any point is equal to the X coordinate squared. (e.g.: for node 4 the X-value is 50% or 0.5. The resultant Y-value is $0.5 \times 0.5 = 0.25$ or 25%).

This example uses 5 segments to approximate the square function curve (i.e., $y=x^2$). Segments 1 through 5 are needed, so nodes 1 through 6 are used.

The following methods can be used to configure a user-defined characterization curve.

Change the user-defined characterization:

HART method

Command: DemNode1X

Enter desired X-value as a percentage for node 1

Command: DemNode1Y

Enter desired Y-value as a percentage for node 1

Repeat above procedures for each node required.

DD Menu Location: MENU 5A

Functions>Configuration>Demand Setup>Dem Curve Spcl

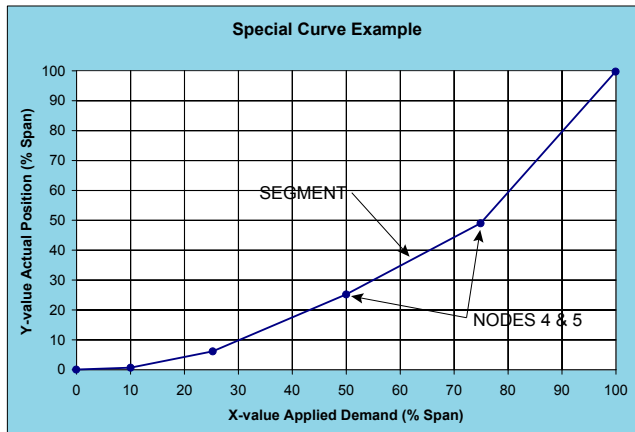

NODE	X-VALUE (DEMAND) % SPAN	Y-VALUE (POSITION) % SPAN
1	0%	0%
2	10%	1%
3	25%	6%
4	50%	25%
5	75%	49%
6	100%	100%

Serial command method

Change the user-defined characterization:

Command: charset *n1*, *n2*, *n3*

Arguments: *n1*, *n2*, *n3*

Where:

n1 = node number.

n2 = X-value as a percentage.

n3 = Y-value as a percentage.

Values must be separated by commas as shown.

Repeat procedure for each node required.

View the user-defined characterization:

Command: charlist ###

Arguments: ### Enter node number between 1 and 21 or "all".

Displays defined nodes.

Clear the user-defined characterization:

Command: charclear ###

Arguments: ### Enter node number between 1 and 21.

Clears a defined node by setting it to unused.

Will also clear any node numerically higher.

CONFIGURATION/CALIBRATION

POSITION FEEDBACK SIGNAL

DCM-2 control electronics provide a 4–20 mA analog output signal that represents the actuator output shaft position. The DCM-2 monitors an internal position voltage from the CPS-4, controls the actuator position, and sources a 4–20 mA signal to terminals 16 (–) and 17 (+). The Feedback will correspond with the 0% and 100% output shaft positions, as determined by the position calibration (page 30). **There is no need for separate Feedback calibration.**

The user has the option of enabling or disabling the position Feedback signal. The factory default configuration will have the Feedback enabled. When the Feedback is enabled, but not in use (i.e., not wired to a load) the "STAT" and "FB OPEN" LEDs will illuminate. This status alarm is helpful in alerting the user to open Feedback wiring, but can be a nuisance when the Feedback is purposely disconnected or unused. Disabling the Feedback signal turns off the output and eliminates the status alarm. If HART or Serial communications are not immediately available to disable the Feedback signal, you can apply (up to) an 800 ohm load resistor across the Feedback terminals 16 (–) and 17 (+) to simulate a Feedback loop and eliminate the alarm.

Use the HART or Serial Commands (detailed on the next page) to set the Feedback signals and corresponding output shaft positions as detailed below.

If desired, the milliamp position Feedback values for 0% and 100% positions can be configured differently than the respective standard factory calibration of 4 mA and 20 mA. A valid 0% position Feedback signal value can be configured anywhere in a 3–16 mA range, while a 100% signal value can be configured from 7–21 mA. The 100% milliamp value must exceed the 0% value by at least 4 mA.

Also, reversed (decreasing direction) Feedback may be selected so that the position resulting from a 4 mA Feedback signal corresponds to the position typically resulting from a 20 mA signal; e.g., 4 mA = 100% position and 20 mA = 0% position. Setting the 0% position to 20 mA will automatically set the 100% position to 4 mA (and vice-versa), and will activate the reverse (decreasing) Feedback function. After accepted, these settings may then be changed as detailed in the paragraph above, only opposite; i.e., a valid 0% position Feedback value is 7–21 mA, while a 100% position may be set at 3–16 mA. The difference between the values can be no less than 4 mA and no greater than 18 mA.

The factory calibrated relationship between the position Feedback signal and the output shaft position is linear (i.e., 0% to 100% Feedback signal corresponds directly with 0% to 100% shaft position). This relationship is suitable for most applications; however, the Feedback to Demand relationship can be changed to compensate for characterized Demand signals. This relationship is called "Inverse Demand". Configuring this option allows the position Feedback signal to match the uncharacterized Demand signal rather than true output shaft position.

The following example assumes 4–20 mA Demand and position signals. If the Demand is set to a square characterization, then a 12 mA Demand corresponds to 25% position. If the position Feedback curve is set to linear, then Feedback at 25% is 8 mA. For some control systems, having the Demand at 12 mA and the Feedback at 8 mA may cause a deviation alarm. The Feedback curve can be set to "Inverse Demand" so the Demand and Feedback match when the actuator is balanced. In this example, with Feedback set to "Inverse Demand" and the output shaft position at 25%, the Feedback signal would be 12 mA.

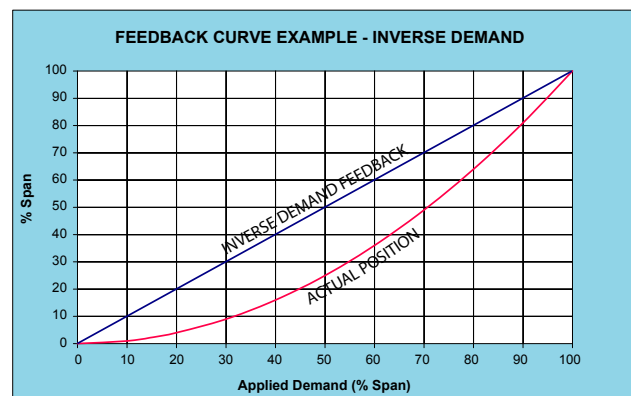
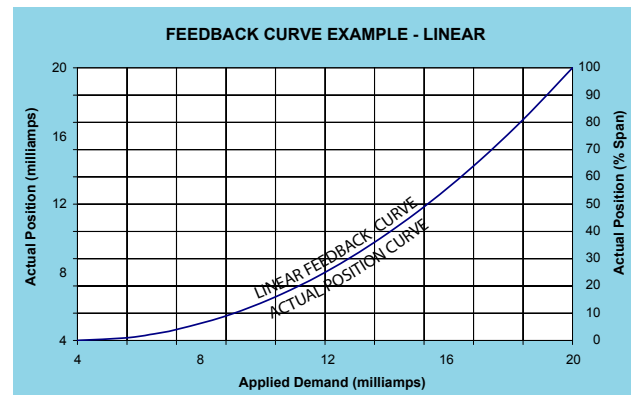

The following methods describe how to enable or disable position Feedback, set the 0% and 100% milliamp values and select the desired Feedback response.

Enable/disable the position feedback:

HART method

Command: Feedback

DD Menu Location: MENU 4E

Functions>Configuration>Feedback Setup>

Selections:

Enabled - to enable position Feedback.

Disabled - to disable position Feedback.

Serial command method

Command: iomode *n*

Arguments: *n*

0: Feedback disabled.

1: Feedback enabled.

Set the feedback range lower and upper values:

HART method

Command: FB RngLwr

Enter the milliamp value that corresponds with 0% position. Acceptable range "3.00"–"16.00" (typically, "4.00").

Command: FB RngUprr

Enter the milliamp value that corresponds with 100% position. Acceptable range "7.00"–"21.00" (typically, "20.00").

DD Menu Location: MENU 4E

Functions>Configuration>Feedback Setup>

Serial command method

Command: fdbk0pctma #.##

Arguments: #.## Desired Feedback signal in mA at 0% output shaft position. The value limit may be no less than "3.00" or, if reversed (decreasing direction), no greater than "21.00".

Command: fdbk100pctma #.##

Arguments: #.## Desired Feedback signal in mA at 100% output shaft position. The value limit may be no greater than "21.00" or, if reversed (decreasing direction), no less than "3.00".

Set the feedback characterization curve:

HART method

Command: FB Curve

DD Menu Location: MENU 4E

Functions>Configuration>Feedback Setup>

Selections:

Linear - to enable a linear feedback signal

InvDem - to enable an inverted Demand feedback signal.

Serial command method

Command: fdbkfunc *n*

Arguments: *n*

0: Linear Feedback signal.

1: Inverse Demand Feedback signal.

CONFIGURATION/CALIBRATION

TORQUE SENSING

Group 22 actuators are equipped with torque sensing. This technology allows for torque measurement, historic data collection, overtorque alarms and overtorque protection.

The torque applied at the output shaft of the actuator is measured and reported as a percentage of the rated actuator torque (e.g., a 3,000 lb-ft model 22-309 with a 50% torque reading is applying 1,500 lb-ft of torque). The live torque measurement can be accessed through HART communications (MENU 1) or serial port (torq command). Historical peak measurements are recorded for 10 equal segments of travel in both the CW and CCW travel directions. This historic data is available through HART communications (MENU 4J & 4K) or serial port (torqprof command).

Proper configuration of the torque sensor is necessary to take advantage of its features. A “torque null” and a “torque constant” value, which are analogous to a zero and a span are unique to each actuator and will be affixed to the body of the unit inside of the DCM compartment. These values will be factory configured on the DCM-2, but will require configuration if the DCM-2 is ever replaced.

When the torque reaches an alarm threshold (factory configured for 105%), a status alarm will be initiated causing the STAT and TORQUE LEDs to illuminate. The threshold can be configured to alarm between 60% and 105%. Disabling the torque sensor also disables the torque alarm. When the measured torque drops below the threshold the status alarm is automatically reset.

The following methods allow the user to enable/disable torque sensing, set the torque null, and set the torque constant. Methods for using and configuring the other torque features also follow:

Enable / disable torque sensing:

HART method

Command: Trq/Thrust

DD Menu Location: MENU 4F

Functions>Configuration>Torque Setup>

Selections:

Enabled - to enable torque sensing.

Disabled - to disable torque sensing.

SERIAL command method

Command: torqenable *n*

Arguments: *n*

0: disables torque sensing and torque alarm.

1: enables torque sensing and torque alarm.

Set the torque null and constant values:

HART method

Command: Trq Null

Number representing 0% torque. Enter the torque null value that is affixed to the actuator body inside the DCM compartment.

Command: Trq Const

Number representing the torque span value. Enter the torque constant value that is affixed to the actuator body inside the DCM compartment.

DD Menu Location: MENU 4F

Functions>Configuration>Torque Setup>

SERIAL command method

Command: torq0k ###

Arguments: ### Number representing 0% torque. Enter the torque null value that is affixed to the actuator body inside the DCM compartment.

Command: torqconst ###

Arguments: ### Number representing the torque span value. Enter the torque constant value that is affixed to the actuator body inside the DCM compartment.

LIVE / HISTORICAL TORQUE

The live torque measurement can be accessed through the HART or serial port interface. Historical peak measurements are recorded for 10 equal segments of travel in both the CW and CCW travel directions. Historic data is also available through the HART or serial port interface.

View the live torque measurement:

HART method

Command: Trq/Thrust

Displays the present torque reading as a percentage of the actuator's rated torque.

DD Menu Location: MENU 1

SERIAL command method

Command: torq

Displays the torque on the output shaft measurement as a percentage of actuator rating.

Arguments: No argument required.

View historical peak torque values:**HART** method

Command: Segment 1 through 10
Displays the historical peak torque values. Values are displayed for every 10% segment of full actuator travel and also for both the CW and CCW directions of travel.

DD Menu Location: MENU 4J
Functions>Diagnostics>CW Torque

DD Menu Location: MENU 4K
Functions>Diagnostics>CCW Torque

SERIAL command method

Command: torqprof

Displays a three table column:
1. Travel divided into 10 segments
2. peak torque measured in each segment with motor running CW
3. peak torque measured in each segment with motor running CCW

Arguments: No argument required.

OVERTORQUE PROTECTION

Overtorque protection is a feature that protects both the actuator and driven equipment from damage by removing motor power when the torque exceeds the set threshold (configurable). Actuators normally ship from the factory with this feature disabled, but it can be enabled in the field using either HART or the Serial interface. The factory configured threshold is 115% of rated actuator torque, and can be configured as low as 25%.

The following methods show how to enable/disable the overtorque protection and how to set the threshold.

Enable / disable overtorque protection:**HART** method

Command: Ovt Prot

DD Menu Location:MENU 4F
Functions>Configuration>Torque Setup>

Selections:

Enabled - to enable overtorque protection.

Disabled - to disable overtorque protection.

SERIAL command method

Command: ovtstop *n*

Arguments: *n*

0: disables overtorque protection.

1: enables overtorque protection.

Set the overtorque protection threshold:**HART** method

Command: ShutDwnTrq
Enter the overtorque protection threshold as a percentage of rated torque (25%–115%).

DD Menu Location:MENU 4F
Functions>Configuration>Torque Setup>

SERIAL command method

Command: ovtstoplevel ###

Arguments: ### the overtorque protection threshold as a percentage of rated torque (25% to 115%).

OVERTORQUE ALARM

When the torque reaches an alarm threshold (factory configured for 105% of rated torque), a status alarm will be initiated causing the STAT LED to illuminate. Disabling the torque sensor also disables the torque alarm. When the measured torque drops below the threshold the status alarm is automatically reset.

The following method allows the user to set the torque alarm threshold between 20% and 105%.

Set the torque alarm threshold:**HART** method

Command: AlarmLevel
Enter the alarm level as a percentage of torque (20%–105%).

DD Menu Location:MENU 4F
Functions>Configuration>Torque Setup>

SERIAL command method

Command: torqalarm ###

Arguments: ### Alarm level as a percentage of torque (20%–105%).

CONFIGURATION/CALIBRATION

TEMPERATURE SENSING

DCM-2s are equipped with an internal temperature sensing circuit. The real-time temperature and the historical temperature extremes (low and high) are available.

Temperature units can be selected to show either Fahrenheit or Celsius.

An alarm condition initiates if the actuator's real-time temperature falls outside the actuator rating (see "General Specifications", page 4). The STAT LED and the TEMP F LED will light, and will automatically reset when the temperature is once again within the actuator rating.

View real-time temperature & historical extremes:

HART method

Command: Temp

Displays the real-time temperature as read by the DCM-2.

DD Menu Location: MENU 1

Command: High Temp

Displays the historical high temperature.

Command: Low Temp

Displays the historical low temperature.

DD Menu Location: MENU 3D

Functions>Statistics

Serial command method

Command: temperature

Arguments:

When entered with no argument, the command returns the real-time temperature as well as the historical high and low temperatures.

Set temperature units:

HART method

Command: Temperature Unit

DD Menu Location: MENU 4B

Functions>Configuration>General Setup

Selections:

degF - Set the temp. units to degrees Fahrenheit.

degC - Set the temp. units to degrees Celsius.

Serial command method

Command: temperature *n*

Arguments: *n*

F: Set the temp. units to degrees Fahrenheit.

C: Set the temp. units to degrees Celsius.

STALL PROTECTION

The DCM-2 board provides protection for the actuator in the event of a stall. Stall protection is activated when the actuator is unable to achieve the proper position within a defined stall time due to a mechanical impediment or excessive load.

The DCM-2 senses when the motor moves the output shaft in one direction longer than the configured "stall time". The DCM-2 then shuts off power to the motor, preventing further actuator movement. When the stall condition occurs, the STALL LED will illuminate.

Resetting due to a stall condition is achieved by reversing the Demand signal, cycling the actuator power, or submitting a reset command via HART or Serial port.

The stall protection feature can be enabled or disabled and the stall time may be configured between 30 and 450 seconds. This feature is factory enabled and the default setting is 300 seconds. If reconfiguring, it is advisable to configure the stall time with a value greater than the maximum stroke time to avoid false stall protection events and alarms.

Enable / disable stall protection:

HART method

Command: StallProt

DD Menu Location: MENU 4B

Functions>Configuration>General Setup>

Selections:

Enabled - to enable stall protection.

Disabled - to disable stall protection.

Serial command method

Command: stallprot *n*

Arguments: *n*

0: stall protection disabled.

1: stall protection enabled.

Configure the stall time:

HART method

Command: Stall Time

Enter the stall time in seconds. Valid stall times are 30 to 450 seconds.

DD Menu Location: MENU 4B

Functions>Configuration>General Setup>

Serial command method

Command: stalltime ###

Arguments: ### Enter the stall time in seconds. Valid stall times are "30" to "450".

Reset a stall condition:

HART method

Command: Reset Stall

Select to reset a stall condition.

DD Menu Location: MENU 3E

Functions>Manual Operation>

Serial command method

Command: unSTALL

Enter to reset a stall condition.

MAINTENANCE

RECOMMENDED REPLACEMENT KITS

Description	Actuator Model			Kit Part No	Instruction Part No.
	22-309	22-409	22-809		
Control End Assembly	●	●	●	12-8061-35	80-4281-05
DCM (1-phase, p/n 12-8224-41)	●			12-8061-75	80-4281-04
DCM w/ Fdbk Display (1-phase, p/n 12-8224-61)	●			12-8061-81	80-4281-04
DCM (1-phase, CE rating, p/n 12-8224-45)	●			12-8061-78	80-4281-04
DCM (3-phase, p/n 12-8224-51)		●	●	12-8061-85	80-4281-24
DCM (3-phase, CE rating, p/n 12-8224-55)		●	●	12-8061-88	80-4281-24
Gasket Set	●	●		12-8061-09	80-4281-09
Gasket Set			●	12-8061-29	80-4281-29
*Fuse Kit, 8A DCM, 22-309 (120 Vac, 1-phase) & 22-409 (208 Vac, 3-phase)	●	●		12-8061-53	80-4281-53
*Fuse Kit, 8A DCM, 4A Power (380/416/480/575 Vac; 3-phase)			●	12-8061-52	80-4281-52
*Fuse Kit, 8A DCM, 10A Power (208, 240 Vac; 3-phase)			●	12-8061-51	80-4281-51

*Note: Select Fuse Kit based on the actuator operating voltage.

ADDITIONAL REPLACEMENT KITS

Description	Actuator Model			Kit Part No.	Instruction Part No.
	22-309	22-409	22-809		
CPS-4 Switch Assembly	●	●	●	12-8061-36	80-4281-06
CPS-4 P.C. Board	●	●	●	12-8061-07	80-4281-07
CPS-4 Coupling	●	●	●	12-8061-08	80-4281-08
Mounting Shim Set	●	●	●	12-8061-11	80-4281-11
Handswitch Assembly	●	●	●	12-8061-12	80-4281-12
Capacitor	●			12-8061-14	80-4281-14
Motor	●	●		12-8061-01	80-4281-01
Motor w/ Hand crank Assembly			●	12-8061-20	80-4281-20
Hand crank Assembly			●	12-8061-27	80-4281-27
Handwheel / Dampener	●	●		12-8061-02	80-4281-02
Handwheel / Dampener			●	12-8061-22	80-4281-02
Self-Locking Mechanism (SLM) Rebuild	●	●		12-8061-69	80-4281-69
Self-Locking Mechanism (SLM) Rebuild			●	12-8061-23	80-4281-23
Service Screw Set	●	●		12-8061-10	80-4281-10
Service Screw Set			●	12-8061-30	80-4281-30
**Surge Suppressor (120 Vac, 1-phase)	●			12-8061-44	80-4281-41
**Surge Suppressor (240 Vac, 1-phase)	●			12-8061-42	80-4281-41
**Surge Suppressor (208 Vac, 3-phase)		●		12-8061-43	80-4281-41
**Surge Suppressor (208 Vac, 3-phase)			●	12-8061-45	80-4281-45
**Surge Suppressor (240 Vac, 3-phase)			●	12-8061-46	80-4281-45
**Surge Suppressor (380 Vac, 3-phase)			●	12-8061-54	80-4281-45
**Surge Suppressor (416 Vac, 3-phase)			●	12-8061-55	80-4281-45
**Surge Suppressor (480 Vac, 3-phase)			●	12-8061-47	80-4281-45
**Surge Suppressor (575 Vac, 3-phase)			●	12-8061-48	80-4281-45

**Note: Select Surge Suppressor Kit based on the actuator operating voltage.

REPLACEMENT TRANSFORMER FUSES FOR OPTIONAL OPERATING VOLTAGES

Description	Actuator Model			Part No.
	22-309	22-409	22-809	
Transformer Fuse (9A, 208 Vac) (3 req'd)	●	●		11-1372-10
Transformer Fuse (8A, 240 Vac) (3 req'd)	●	●		11-1372-09
Transformer Fuse (4A, 380 Vac) (3 req'd)	●	●		11-1372-06
Transformer Fuse (4A, 416 Vac) (3 req'd)	●	●		11-1372-06
Transformer Fuse (4A, 480 Vac) (3 req'd)	●	●		11-1372-06
Transformer Fuse (3.5A, 575 Vac) (3 req'd)	●	●		11-1372-08

COMPONENT REPLACEMENT

The Group 22 has a modular design to allow for ease of maintenance and parts replacement. The individual components of the actuator are available in replacement kits as detailed below. Each replacement kit includes the component(s), hardware and detailed instructions necessary for efficient installation of the replacement parts.

HOW TO ORDER SPARE PARTS

Any customer replacement kit may be purchased for spare parts, however several kits have been selected by the factory as recommended spares. Contact your Beck Sales Engineer for questions regarding recommended replacement parts particular to your application. Parts may be ordered by mail, telephone, fax or e-mail, with the confirming order sent to the factory.

ROUTINE MAINTENANCE

Beck actuators require only a minimum of routine maintenance. At regular plant maintenance intervals, a visual inspection is recommended to verify that the connection to the final control element is intact and operating normally. If vibration is present, check the electrical terminal connections and other hardware for tightness. Check the conduit seals for any moisture penetration and reseal if necessary.

LUBRICATION

The Group 22 actuator has a grease filled gear housing, so periodic lubrication is not required. However, to extend the life of the linkage, rod ends should be lubricated periodically.

GASKETS

During routine service, inspect removed cover gaskets for wear or damage. In order to protect internal components, worn or damaged gaskets and O-rings should be replaced.

To remove, scrape all of the old adhesive and gasket material from the body housing and cover. The DCM cover, Terminal Block cover and Position Sensing (Control End) cover have self-adhering, silicone rubber gaskets. Peel the backing off the replacement gasket and carefully apply to the actuator body. Other gaskets are a cork-rubber composite. Cement the new gasket to the actuator body using a gasket cement such as 3M #847 Rubber and Gasket Adhesive, or equivalent.

MOTOR

The motor assembly is not field-repairable. Disassembly of the motor will result in a loss of torque that can only be restored by returning the motor to the factory for re-magnetizing.

The motor assembly may be replaced, however, if necessary. Detailed instructions are included with the proper replacement kit (see page 42) or may be accessed through our website (www.haroldbeck.com).



CAUTION

To prevent sudden movement, block the actuator crank arm before removing the motor—failure to do so could cause serious injury or damage to equipment.

SELF-LOCKING MECHANISM (SLM)

An integral part of every Beck motor is the Self-Locking Mechanism. This mechanical device couples the motor to the gear train and transmits full motor torque in either direction. When the motor is de-energized, the SLM prevents back driving of the output shaft.

The SLM may be replaced, if necessary. Detailed instructions are included with the proper replacement kit (see page 42) or may be accessed through our website (www.haroldbeck.com).

MAINTENANCE

FUSES

Group 22 actuators are equipped with fuses to protect the wiring and electronics from over-current conditions. If the fuses clear, either excessive voltage was connected to the drive, or an internal actuator short circuit or failure exists. The fuses will not clear due to actuator stalls or heavy duty cycles.

If a fuse(s) clears, first check the applied voltage against the voltage rating stamped on the nameplate of the actuator. If the applied voltage appears correct, switch off all power, replace the cleared fuse(s) and restore power. If the actuator operates properly, there may have been a momentary problem with the applied power.

22-309 / 22-409

The 22-309 has two fuses and the 22-409 has three fuses (similar to the 22-809 - see the image below), which are located in fuse holders on the DCM-2 chassis assembly. Note that the DCM-2 circuit boards are not powered through the fuses, and therefore the Control Board will remain active if the fuses are cleared. 240 Vac actuators also have a power fuse located next to the DCM-2 board.

22-809

The 22-809 has two sets of three fuses. One set of these fuses is electrically connected between the terminal block and the main three-phase power transformer. If these fuses are cleared, the actuator will have no functionality. These three fuses are located in the upper left area of the DCM2 compartment (see illustration below). To access these fuses, the DCM-2 chassis assembly must first be removed from the compartment.

The other set of three fuses is located on the DCM-2 in fuse holders. Note that the DCM-2 circuit boards are not powered through the DCM-2 fuses, and therefore the Control Board will remain active if the DCM-2 fuses are cleared.

Refer to the customer replacement kit tables (page 42) to order the proper replacement fuse kit for your actuator.

LOCATION OF FUSES

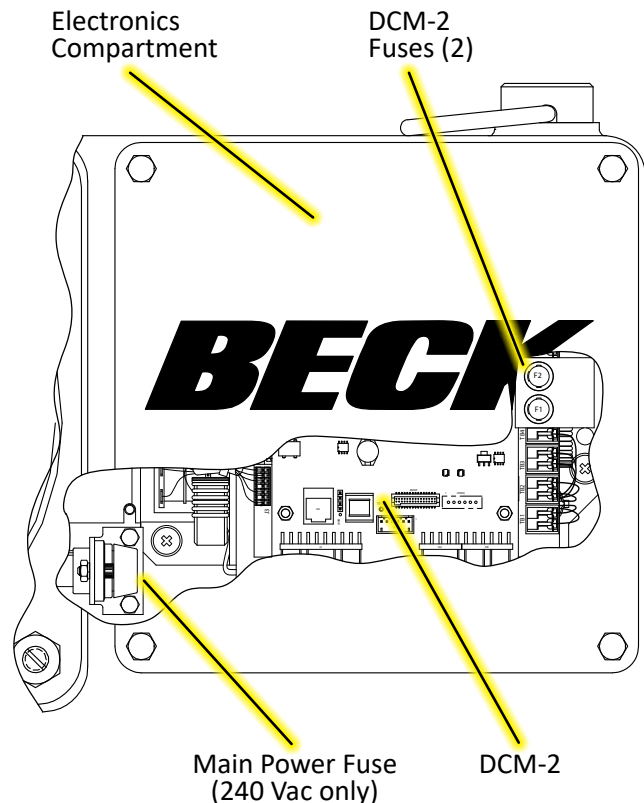

22-309

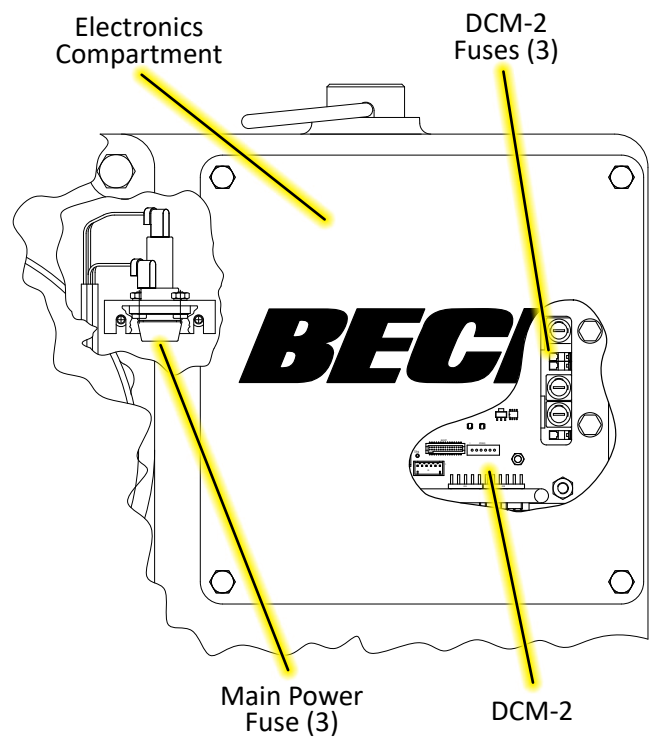

22-809

DCM-2 REPLACEMENT

The following procedure describes the steps required to replace the Digital Control Module (DCM-2) chassis assembly. These instructions are applicable for DCM-2 Replacement kit numbers 12-8061-75, 12-8061-78 & 12-8061-81 (for model 22-309) and 12-8061-85 & 12-8061-88 (for models 22-409 / 22-809).

The Group 22 operating parameter table provides a list including some of the more important parameters that may require configuration when replacing a DCM-2. Review and obtain these settings from the original DCM using HART or serial port commands (if possible) so they may be configured on the new DCM-2. A DCM serial cable kit is included with the DCM-2 replacement kit.

OPERATING PARAMETERS

(These values will be used to check the calibration of the actuator after the replacement DCM-2 is installed).

Operating Parameters	Recorded Value	HART Interface			Serial Interface	
		HART Menu	Variable Name	Default Value	Command	Default Value
Drive Rotation (Increasing Signal)		3A	Drive Dir	CW	drvrotation	0 (CW)
Operation Mode		4G	Op Mode	Follow	opmode	0 (follow)
Torque Zero		4F	Trq Null	0*	torq0k	0*
Torque Constant		4F	Trq Const	550*	torqconst	550*
CPS Volts at 0 Degrees		4C	CPS Zero%	1.300	cpsvat0deg	1.300
CPS Volts per 100 Degrees		4C	CPS Span	2.400	cpsvper100deg	2.400
Travel		4B	Travel	100.0	travel	100.00
Demand LOS Threshold (mA)		4D	DemLimLwr	3.20	demlos	3.20
Demand LOS Mode		4D	LOS Mode	Stay	demlos	sip
Demand LOS Go To Position (%)		4D	LOS Pos	50.00	demlosgtp	50.00
0% Demand (mA)		4D	DemRngLwr	4.00	dem0pctma	4.00
100% Demand (mA)		4D	DemRngUpr	20.00	dem100pctma	20.00
Stall Time (Sec)		4B	Stall Time	300	stalltime	300
Demand Function		4D	Dem Curve	Linear	demfunc	linear
Step Size		4B	Step Size	0.10	stepsize	0.10
IO Mode		4E	Feedback	Enabled	iomode	1 (fdbk)
0% Feedback (mA)		4E	FB RngLwr	4.00	fdbk0pctma	4.00
100% Feedback (mA)		4E	FB RngUpr	20.00	fdbk100pctma	20.00
Torque Enable		4F	Trq/Thrust	Enabled	torqenable	1 (enabled)
Over Torque Stop		4F	Ovt Prot	Disabled	ovtstop	0 (go)
Polling Address		3B	Poll Addr	0	polladdr	0
Drive Model		3B	Model#	22-309	drvmodel	12 (22-309)

*Default values only--the specific numbers for these values are unique to each actuator and are determined during manufacture. These specific numbers are noted on a tag affixed to the actuator body within the Electronics Compartment. Default values should only be used if the specific numbers are unknown.

REQUIRED TOOLS

FOR ALL MODELS

- 1/2" socket wrench
- Torque wrench appropriate for 10 lb-ft (14 N•m)
- Communications device for calibration

Additional Tools for Model 22-309

- #3 Phillips head screwdriver
- Torque screwdriver with #3 Phillips head bit (appropriate for 50 lb-in (6 N•m))

Additional Tools for Model 22-409 & 22-809

- 7/16" hex socket wrench
- Torque wrenches appropriate for 50 lb-in (6 N•m) and 10 lb-ft (14 N•m)

Continued

MAINTENANCE

DCM-2 REPLACEMENT (CONT'D)



CAUTION

To prevent electrostatic discharge damage to the electronics, wear a grounding strap during this procedure.

For the replacement DCM-2 to operate properly, the DCM-2 settings must match the existing application. It is particularly important to verify the actuator rotation corresponding to an increasing Demand signal (CW or CCW). It is also important to verify the travel (degrees) setting. The table on page 45 lists the factory default values for the operating parameters of the DCM-2.

If HART® or Serial communication is still possible with the DCM-2 which is being replaced, read and record the values listed in the table on page 45. These values can be obtained through a HART® handheld communicator or through the RS-232 connection (J20) and the Beck Serial Commands.

If it is not possible to obtain the operating parameters through the DCM-2 being replaced, contact the factory with your actuator serial number to obtain the configuration settings as shipped.



WARNING

Electrical shock hazard. Disconnect power before proceeding. Remove the actuator from line voltage and disconnect any external power sources feeding the auxiliary switches.

Remove the DCM-2 assembly:

1. Remove the electronic compartment cover (5/16-18 x 1.75" (4) captive hex head screws).
2. Ensure power to the actuator has been disconnected.
3. Disconnect the (4) wiring connection points and the ribbon cable connection as shown in the closest applicable illustration on page 23.
4. Loosen the captive DCM-2 mounting screws. Use the #3 Phillips head screwdriver (4 screws) for model 22-309. Use the 7/16" socket wrench (6 screws) for models 22-409 & 22-809.
5. Using a gentle rocking motion, remove the DCM-2 from the actuator.

Install the new DCM-2 assembly:

6. Align the locating pin holes in the DCM-2 assembly with the pins in the rear wall of the electronic compartment in the actuator.

7. Push the DCM-2 back to its mounting surface and tighten the captive mounting screws to 50 lb-in (6 N•m).
8. Reconnect the wiring connections and ribbon cable connection.
9. Reconnect power to the actuator.
10. Ensure that the DCM-2 is configured properly.
11. Check the state of the LEDs on the DCM-2. If the FWD or REV LED is lit, the actuator will begin to position when the Handswitch is placed in AUTO. If desired, change the Demand signal or reposition the actuator using the Handwheel until both the FWD and REV LEDs are out; the Handswitch can then be placed in AUTO without the actuator repositioning.

Check actuator calibration:

Ensure that the actuator calibration is correct and the values previously recorded (or obtained from the factory) are correctly set in the new DCM-2. Values may be entered using a HART handheld communicator or the RS-232 connection and the Beck Serial Commands.

Also, ensure that the gear ratio setting is appropriate for the stroke timing of the actuator (see page 7).

In order for the torque functions of the actuator to operate properly, accurate torque sensor range values (i.e., torque zero and torque constant) must be entered. These values are specific to each actuator and are recorded on a tag inside the electronic compartment.

Before replacing the electronic compartment cover:

1. Inspect the cover gasket and replace if the gasket shows any wear or damage. If the gasket looks good, skip steps 2–3.
2. Clean the mating surface of the actuator body and compartment cover to remove any remaining gasket material and adhesive. Ensure that the mating surfaces are free of defects or gouges.
3. Peel the backing off the replacement gasket and carefully apply to the actuator body.
4. Replace the electronic compartment cover (torque the hex head captive screws to 10 lb-ft (14 N•m)).

CONTROL END REPLACEMENT

The following procedure describes the steps required to replace the Control End assembly using the control end replacement kit part number 12-8061-35. The kit includes the control end which is comprised of a contactless position sensor (CPS-4), a limit switch assembly, some screws and washers, and a control end gasket for replacement if necessary.

The replacement control end assembly has been fully calibrated at the factory. This replacement procedure will return the actuator to a close approximation of its original calibration. Do not calibrate the actuator until this procedure is complete, and then only if necessary.

REQUIRED TOOLS

- 1/2" socket wrench
- 3/32" hex driver
- Torque wrenches
(appropriate for 12lb-in(1.4N•m) & 10lb-ft(14N•m))
- Fine point marker
- 3/16" flat-tipped screwdriver



WARNING

Electrical shock hazard. Disconnect power before proceeding. Remove the actuator from line voltage and disconnect any external power sources feeding the auxiliary switches.



CAUTION

To prevent electrostatic discharge damage to the electronics, wear a grounding strap during this procedure.

Remove the control end assembly:

Refer to the photo below for component identification.

1. Disconnect power from the actuator.
2. Remove the control end cover by loosening the (4) set screws (1/2" socket wrench) and pulling the cover straight away from the actuator -- being careful to not damage the control shaft or position sensing assembly within.

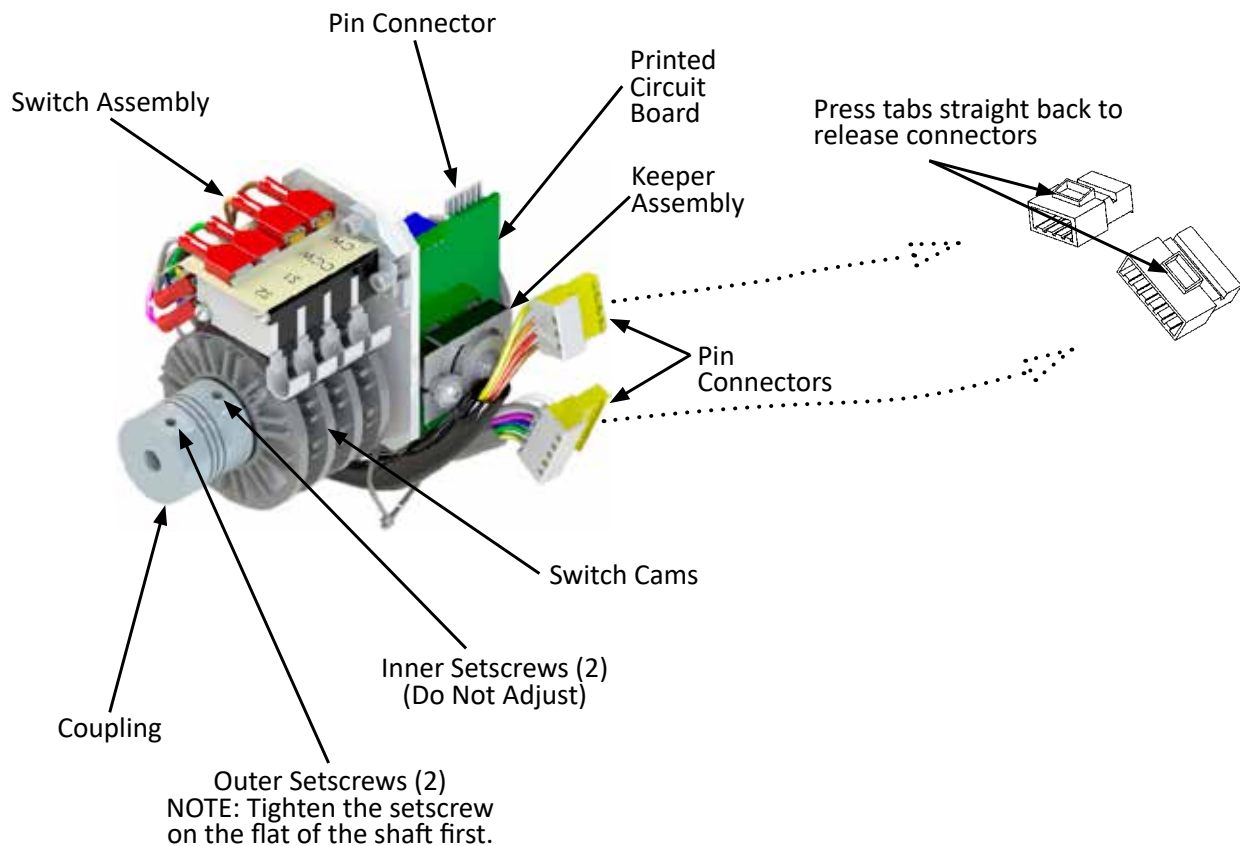

MAINTENANCE

CONTROL END REPLACEMENT (CONT'D)

3. Disconnect the control end assembly electrical circuits by unplugging the three pin connectors from the actuator. Two of the connectors lead from the switch subassembly and the other connector leads from the printed circuit board. To disconnect the switch subassembly connectors, use a 3/16" flat-tipped screwdriver to press the release tab back and pull the connector out of its socket. The connector from the printed circuit board pulls off with modest force.
4. Loosen the two outermost setscrews on the coupling. **Do not** loosen the inner setscrews.
5. Use a fine point marker to note the position of the control end relative to the actuator body. Mark the actuator's face immediately adjacent to the top of the notch (see photo at right).
6. Loosen (do not remove) the four mounting clamp button head screws and slide the top clamp up over the edge of the shoulder in the body, immediately above the stator flange. Snug one of the screws on the top clamp to hold it up while replacing the assembly. Allow the bottom clamp to hang by the screws.
7. Slide the control end assembly away from the actuator until it clears the control shaft.

Install the new control end assembly:

8. Inspect the control end gasket and replace as necessary. If the gasket is in good condition, skip to Step 13.
9. Protect the new control end assembly with a static-free cover.
10. Clean the mating face of the actuator body to remove all gasket material and adhesive. Use caution not to damage or bend the control shaft. Ensure that the mating surface is free from damage (i.e., dents, gouges, etc.).
11. Peel the backing off the replacement gasket and carefully apply to the actuator body.
12. Remove the protective cover from the new control end assembly.
13. Slide the new assembly onto the shaft, turning the coupling (if necessary) to align the assembly with the shaft. Align the notch in the stator with the locating pin situated to the left of the control end shaft.
14. Loosen the clamp screw to allow the top clamp to drop into place over the upper rim of the stator. Rotate the assembly as necessary to align the the top of the notch with the mark made earlier on the actuator face. Snug the

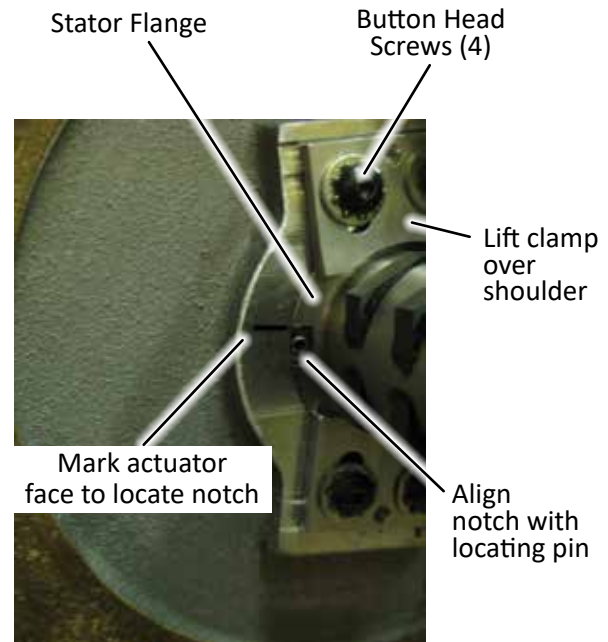

screws down on the plate. Raise the bottom clamp into position and snug its screws down. Check the clamps for proper shoulder clearance and tighten the screws to 12 lb-in (1.4 N•m) torque.

15. Plug the three pin connectors into their proper sockets.
16. Tighten the outer 2 setscrews on the coupling. The screw on the flat of the shaft must be tightened first to properly align the assembly. Torque screws to 12 lb-in (1.4 N•m) torque.

Test for proper operation:

17. Reconnect power to the actuator.
18. Modulate the Demand signal to run the actuator through its full range of motion. Verify the correct actuator response.
19. Modulate the signal to several intermediate levels and note if the actuator attains the proper position.
20. When proper operation is verified, carefully replace the control end cover, tighten the captive cover screws to 10 lb-ft (14 N•m) torque, then return the actuator to service.

TROUBLESHOOTING

The Group 22 actuator was designed to allow for quick diagnosis of any actuator status conditions causing an interruption in operation. Remove the DCM compartment cover to access the DCM-2 and view the Overview and Status indication LEDs (see page 24). These LEDs provide an efficient means of determining the actuator problem, in many cases without the need for metering equipment.

The matrix on the following pages lists some of the potential conditions that may be experienced when troubleshooting.

DCM-2

The DCM-2 board is the control center of the actuator. Actuator configuration and calibration are accessed and set through the DCM-2 board. The DCM-2 has Overview and Status LEDs that indicate status and alarm conditions. More advanced troubleshooting features may be accessed using HART or the Serial connection (see respective appendices in this manual). Reference Menu 3F, Diagnostics menu, for troubleshooting with HART. For Serial port troubleshooting, use the diagnostic commands featured in the Serial port appendix.

The DCM-2 performs an error based positioning function. It accepts a Demand signal, compares it to an internal position Feedback voltage provided by the CPS-4, and controls the motor to correct for a difference. The DCM-2 includes four test points for measuring the Demand and internal position signal voltages at the DCM-2. The Demand signal should measure 1-5 volts DC across test points TP3 (-) and TP2 (+), proportional to the 4–20 mA Demand input signal. The raw position signal should measure approximately 1.3 to 3.7 volts DC across test points TP4 (+) and TP1 (-), proportional to the output shaft's 0–100 degree position (shaft position can be determined by viewing the mechanical index).

The location of the DCM-2 test points are shown on page 23.

CPS-4

The output voltage of the CPS-4 ranges from 1.3 to 3.7 volts DC for 100° actuator shaft rotation. This can be measured across CPS-4 test points TP3(+) and TP1(-). If the position signal is outside the anticipated range, the "STAT" and "POSITION" LEDs will light, and contacts at terminals 12 & 13 will open if the PositionLOS alarm mask bit is ON (default state). When the position signal is corrected, the actuator will automatically resume normal operation. The 5 volts DC CPS-4 power supply can be measured across test points TP2(+) and TP1(-).

The CPS-4 test points are located on the printed circuit board and are shown below.

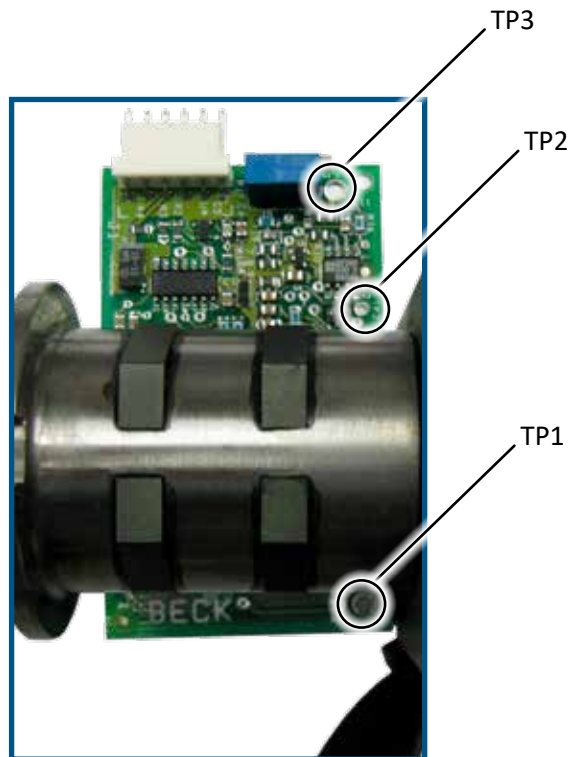

CPS-4 TEST POINTS

TROUBLESHOOTING

CONDITIONS	POSSIBLE CAUSES	CORRECTIONS
1. No DCM-2 LEDs are illuminated.	<ul style="list-style-type: none"> a. No power is applied to the actuator. b. Incorrect power is applied to the actuator. c. Main power fuse/breaker is blown. d. DCM-2 malfunction. 	<ul style="list-style-type: none"> a. Apply operating voltage to the operating voltage terminals. b. Verify correct voltage on actuator nameplate and ensure that it is applied at the operating voltage terminals. c. Verify fuse/breaker integrity. Replace/reset if blown. Find cause of short circuit. d. Replace DCM-2.
2. STAT LED is illuminated.	<ul style="list-style-type: none"> a. A status alarm is active. 	<ul style="list-style-type: none"> a. Check the status indication LEDs on the pushbutton interface of the DCM-2. Continue troubleshooting based on the LEDs that are illuminated.
3. DEMAND LED is illuminated.	<ul style="list-style-type: none"> a. No Demand signal. b. Applied Demand signal is outside of configured range. c. Polarity of applied signal wires is reversed. 	<ul style="list-style-type: none"> a. Apply a Demand signal to terminals 14 (-) & 15 (+). b. Confirm Demand signal value via HART or by measuring DC voltage across DCM-2 test points TP3(+) & TP2(-). Should be 1–5 volts for 4–20 mA applied signal. c. Correct the polarity of the applied control signal wires on terminals 14 (-) & 15 (+).
4. POSITION LED is illuminated.	<ul style="list-style-type: none"> a. Position signal voltage generated by CPS-4 read by the DCM-2 is outside of the configured range. b. CPS-4 malfunction. c. DCM-2 malfunction. 	<ul style="list-style-type: none"> a. Using the HART communicator check the Position Sensor Setup menu to verify the Present CPS voltage falls within the configured CPS Zero% and Span (typical range 1.3–3.7 volts); OR measure DC voltage between DCM-2 test points TP4 (+) and TP1 (-) to verify Present CPS voltage. If the voltage is outside of 1–5 volts, recalibrate the CPS-4 or replace the control end. b. Replace control end. c. Replace DCM-2.
5. TORQUE LED is illuminated.	<ul style="list-style-type: none"> a. Torque exceeding configured limit (typically over 105% of rated torque) is being applied to the output shaft. b. Torque Null and Torque Constant values are not set correctly. c. Torque cable is not connected to DCM-2. 	<ul style="list-style-type: none"> a. Eliminate cause of excessive torque (i.e., binding damper, improper linkage, etc.). b. Locate Torque Null and Constant values inside DCM compartment and set via HART or Serial port. c. Reconnect torque cable to DCM-2.
6. STALL LED is illuminated.	<ul style="list-style-type: none"> a. Actuator has stalled—unable to achieve desired position within the configured “STALL TIME”. b. The configured stall time is less than the configured Max Travel Time. 	<ul style="list-style-type: none"> a. Eliminate the obstruction and reset the stall by reversing direction on your Demand signal, cycling the power, or issuing the stall reset from HART or Serial command. b. Configure the stall time to exceed the Max Travel Time via HART or Serial command.
7. TEMP F LED is illuminated.	<ul style="list-style-type: none"> a. The measured temperature at the DCM-2 is outside of the normal operating range of -40° to 185° F. 	<ul style="list-style-type: none"> a. Protect the actuator from the extreme temperatures below or above the operating range to eliminate the alarm.
8. FB OPEN LED is illuminated.	<ul style="list-style-type: none"> a. The position Feedback circuit current loop is not complete. b. The position Feedback is enabled, but not in use. 	<ul style="list-style-type: none"> a. Ensure the device measuring the 4–20 mA Feedback is properly terminated on terminals 16 (-) and 17 (+) and is applying a 0–800 ohm load resistance. b. Disable Feedback via HART or Serial command; OR terminate the Feedback loop by applying a 0–800 ohm load resistance across terminals 16 and 17.

CONDITIONS	POSSIBLE CAUSES	CORRECTIONS
9. UVOLT LED is illuminated.	<ul style="list-style-type: none"> a. The applied operating voltage is outside of the tolerance (+10%/-15%) of the nameplate operating voltage. b. A DCM-2 fuse is open (or primary transformer fuse on 22-809 is open). c. A component failure has occurred on the DCM-2. 	<ul style="list-style-type: none"> a. Apply the correct operating voltage to the actuator per the voltage stamped on the nameplate. b. Replace the open fuse with the appropriate fuse kit; see page 42. c. Replace the DCM-2.
10. The actuator will only move at a very slow speed when using the Handswitch or override terminals.	<ul style="list-style-type: none"> a. The DCM-2 does not detect a valid position signal from the CPS-4. b. The max. travel time is set to a high value (max. allowable time is 300 seconds) 	<ul style="list-style-type: none"> a. Verify CPS-4 cable connections, check CPS-4 raw position voltage test points TP3 and TP1 for 1.3–3.7 V dc., check CPS-4 power supply test points TP2 and TP1 for 5 V dc and, if necessary, replace control end. b. Adjust max. travel time via HART or Serial closer to the minimum (30 seconds for 22-309 and 15 seconds for 22-409/-809).
11. All LEDs are illuminated or flashing.	<ul style="list-style-type: none"> a. A component failure has occurred on the DCM-2. 	<ul style="list-style-type: none"> a. Replace the DCM-2.
12. FWD or REV LED is illuminated, actuator is not moving, and there are no other status alarms.	<ul style="list-style-type: none"> a. Handswitch is in the STOP position. b. CW or CCW limit switch is open. 	<ul style="list-style-type: none"> a. Turn the Handswitch to the AUTO position. b. Verify limit switch is set outside of electrically calibrated limits & readjust or replace, if necessary.
13. Actuator runs uncontrolled to one end of travel.	<ul style="list-style-type: none"> a. The CPS-4 is malfunctioning. b. The DCM-2 is malfunctioning. 	<ul style="list-style-type: none"> a. Verify CPS-4 cable connections, check CPS-4 raw position voltage test points TP3 and TP1 for 1.3–3.7 V dc, check CPS-4 power supply test points TP2 and TP1 for 5 V dc and replace the control end, if necessary. b. Verify the raw position signal seen by the DCM-2 at test points TP4 and TP1 for 1.3–3.7 V dc. If valid signal is measured, replace DCM-2.
14. Actuator will not hold position with Handswitch in STOP.	<ul style="list-style-type: none"> a. Self-Locking Mechanism (SLM) is damaged. 	<ul style="list-style-type: none"> a. Rebuild the SLM assembly.
15. Actuator PWR LED is flashing, but does not respond to Demand signal, Handswitch or override terminals.	<ul style="list-style-type: none"> a. The emergency override STOP terminal (21) is connected to the common terminal (18). b. The safety shutoff circuit is damaged. c. The Handswitch is damaged. 	<ul style="list-style-type: none"> a. Remove the connection from terminal 21 to terminal 18. b. Contact the factory. c. Replace the Handswitch.
16. HART communications cannot be established with the DCM-2.	<ul style="list-style-type: none"> a. The Device Description (DD) file is not installed. b. The HART communicator is not compatible with Beck equipment. c. The HART communications circuit on the DCM-2 is damaged. 	<ul style="list-style-type: none"> a. Install the Beck MK-2 DD on your HART device. b. Utilize a compatible HART communicator or configure the actuator through the Serial port. c. Replace the DCM-2.
17. Present CPS voltage appears to be within the configured range, but position Feedback signal at terminals 16 and 17 remains constant or erratic.	<ul style="list-style-type: none"> a. The position feedback circuit on the DCM-2 is damaged. 	<ul style="list-style-type: none"> a. Replace the DCM-2
18. Power LED is pulsing bright to dim.	<ul style="list-style-type: none"> a. This is a normal condition indicating the processor is functioning. 	<ul style="list-style-type: none"> a. No action required.
19. Output shaft rotates opposite of desired direction when applying a 4–20 mA Demand signal.	<ul style="list-style-type: none"> a. The rotation direction is incorrectly configured. 	<ul style="list-style-type: none"> a. Configure the rotation direction using pushbutton, HART, or Serial method.

APPENDIX: HART® COMMUNICATION

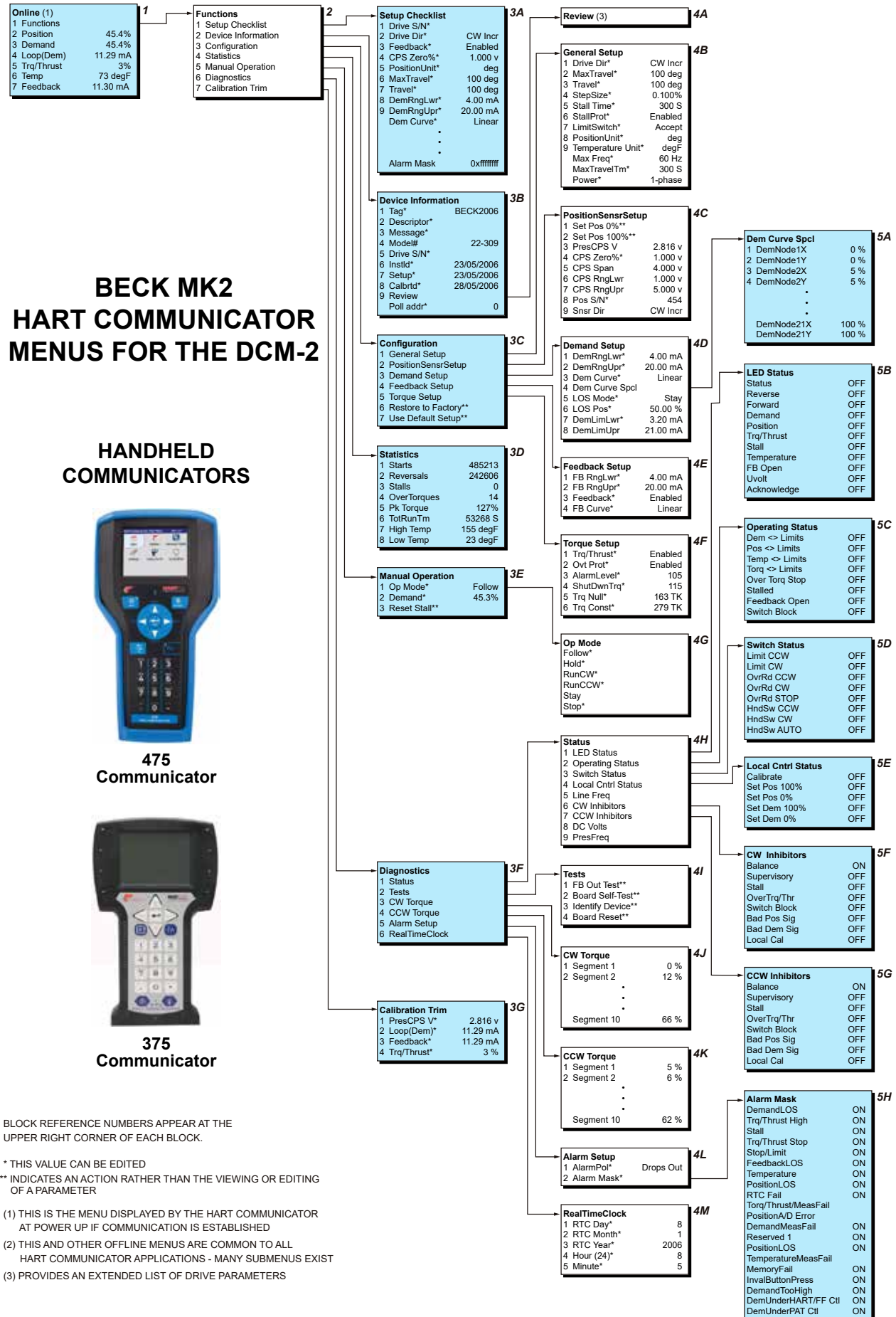

BLOCK REFERENCE NUMBERS APPEAR AT THE UPPER RIGHT CORNER OF EACH BLOCK.

* THIS VALUE CAN BE EDITED
 ** INDICATES AN ACTION RATHER THAN THE VIEWING OR EDITING OF A PARAMETER

- (1) THIS IS THE MENU DISPLAYED BY THE HART COMMUNICATOR AT POWER UP IF COMMUNICATION IS ESTABLISHED
- (2) THIS AND OTHER OFFLINE MENUS ARE COMMON TO ALL HART COMMUNICATOR APPLICATIONS - MANY SUBMENUS EXIST
- (3) PROVIDES AN EXTENDED LIST OF DRIVE PARAMETERS

The DCM-2 board is the control center of the actuator—configuration and calibration are accessed and set through the DCM-2 board. Using the HART interface requires a HART compatible communicator or any device, computer or controller capable of communicating with HART devices and supporting the Beck DCM-2 Device Description.

This instruction supports Group 22 actuators built with DCM-2 part numbers 12-8224-41, 12-8224-45, 12-8224-51 and 12-8224-55.

HART® INTERFACE

The interface menu tree for communicating with a DCM-2 using the BECK-MK2 Device Description is located on the previous page. This menu tree summarizes possible setup options, features and available information.

HART® COMMUNICATORS FOR BECK-MK2

The BECK-MK2 Device Description requires a HART Communicator that is HART 5 capable and has the ability to import Device Description Language Files (DDL) that are certified by the HART Communications Foundation.

USING THE 275, 375 OR 475 HART® COMMUNICATOR

The HART Communicator leads should be connected in parallel with the analog Demand signal wiring (see below). This allows the communicator to simultaneously communicate over the analog input wires. This does not disturb the analog Demand signal, or disrupt the DCM-2 functions. However, any program changes to the DCM-2 will momentarily suspend the operation of the board (maintains last state) while the change is implemented. Typically, this is only for a second or two.

After connected, turn on the communicator and wait for communications to be established. When communications are established, the “Online” display will appear. If the actuator is multidropped with other devices on a HART network, the first display screen will list all devices and require a selection before the “Online” display is shown. Follow the HART DD menu on the previous page to navigate.

NOTE: If the communicator is unable to communicate with the DCM-2, it displays the message, “No Device Found”. If this occurs, check to make sure the leads are securely connected to the Demand wiring and retry. If communications still do not occur, the communicator polling setup may be improperly set. Check the “utility” menu and make sure communications polling is set to “always poll”.

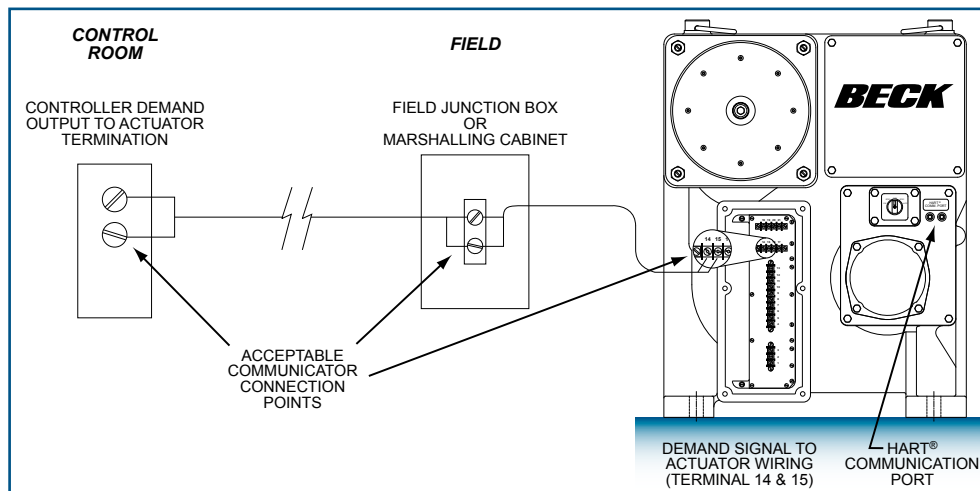

MENU DESCRIPTIONS

(See HART Communicator Menu on page 52)

MENU 1 -- Online

When communications are established with the communicator, the Online menu is displayed.

- 1 Functions:** The link to the menu tree.
- 2 Position:** The output shaft position displayed as a percent of range.

- 3 Demand:** The Demand signal displayed as a percent of range.
- 4 Loop (Dem):** The Demand signal measured in mA.
- 5 Trq/Thrust:** The present torque value as applied to the output shaft (optional).
- 6 Temp:** The ambient temperature of the DCM-2.
- 7 Feedback:** The mA output signal representing the present position of the output shaft.

APPENDIX: HART[®] COMMUNICATION

MENU 2 -- Functions

From the Functions menu, any of the DCM-2 functional menus can be selected and accessed. There are seven functional areas: Setup Checklist, Device Information, Configuration, Statistics, Manual Operation, Diagnostics, and Calibration Trim.

MENU 3A -- Setup Checklist

The Setup Checklist provides a quick way for the user to setup the most important items necessary for basic actuator operation without having to move through multiple sub-menus. These items are defined on the following pages in their specific menu locations.

MENU 3B -- Device Information

The Device Information menu provides information about the actuator. There are ten useful information entries that may be viewed and/or edited.

- 1 Tag:** An 8 character entry that can be used to identify a specific field device label.
- 2 Descriptor:** A 16 character field that can be used to provide any description desired.
- 3 Message:** A 32 character field that can be used to provide any message desired.
- 4 Model#:** Displays the model number of the actuator in which the DCM-2 is installed. This field may be edited. Note that changing this field may cause the "Use Default Setup" command to not function.
- 5 Drive S/N:** The Serial number as shown on the actuator nameplate. When configured, this will automatically change the actuator model number (see previous item).
- 6 Instld:** Installation date of the actuator or DCM-2.
- 7 Setup:** The setup date has no affect on actuator operation.
- 8 Calbrtd:** The calibration date has no affect on actuator operation.
- 9 Review:** Link to the Review menu.
- 10 Poll addr:** Used to find the actuator. Most configurations should use "0".

MENU 4A -- Review

The Review menu displays many of the configured parameters in a read-only format. This menu may help ensure that the DCM-2 is configured as desired.

MENU 3C -- Configuration

The Configuration menu serves as the gateway to all of the actuator operating parameters that can be used to configure the actuator based on the desired operation.

- 1 General Setup:** Link.
- 2 PositionSensrSetup:** Link.
- 3 Demand Setup:** Link.
- 4 Feedback Setup:** Link.
- 5 Torque Setup:** Link.
- 6 Restore to Factory:** Restores field-configurable parameters back to the settings in effect when the DCM-2 was shipped from the factory.
- 7 Use Default Setup:** Changes the DCM-2 position sensing voltage ranges to the proper ranges for the actuator model.

MENU 4B -- General Setup

This menu sets actuator operating parameters. The nine parameter entries are as follows:

- 1 Drive Dir:** The direction the output shaft rotates (looking into the output shaft) in response to an increasing Demand signal.
- 2 MaxTravel:** The maximum available travel distance of the output shaft in degrees. This number corresponds to the actuator design; if the correct Serial Number is entered, this parameter is set to 100° and should not be changed.
- 3 Travel:** The number of degrees of output shaft travel for 100% span (60–100°).
- 4 StepSize:** The smallest Demand change that will cause an output shaft movement (0.1%–2.5%).
- 5 Stall Time:** The amount of time the motor will run (30–300 seconds) before Stall Protection is initiated and power disabled to the motor.
- 6 StallProt:** Set as either "Enabled" or "Disabled".
- 7 LimitSwitch:** This entry is set as either "Accept" or "Alert" and defines whether or not contacting an overtravel limit switch outside of the normal 0% to 100% travel range will cause an alarm condition.
- 8 PositionUnit:** The numeric unit of measure for the output shaft position in angular degrees.
- 9 Temperature Unit:** The unit of measure for temperature sensing. May be "degF" (fahrenheit) or "degC" (celsius).
- 10 Max Freq:** Maximum allowed motor power frequency. This is factory set and should not be changed.

11 MaxTravelTm: The time required for the actuator to travel (100°) between the limits. Model 22-309 is configurable between 30–300 seconds; models 22-409/-809 are configurable between 15–300 seconds.

12 Power: Model 22-309 actuators are configured for “1-phase”; 22-409/-809 are configured for “3-phase”.

MENU 4C -- PositionSensrSetup

This menu contains parameters that determine how the DCM-2 interprets the output shaft position signal from the CPS-4.

- 1 Set Pos 0%:** Sets the 0% position to match the present output shaft position. This does not change the 100% position.
- 2 Set Pos 100%:** Sets the 100% position to match the present output shaft position. Also instructs the DCM-2 to change travel span based on the 0% position. This does not change the 0% position.
- 3 PresCPS V:** Displays the CPS-4 signal voltage at the present output shaft position. Not editable.
- 4 CPS Zero%:** Displays the CPS-4 voltage at the 0% output shaft position. May be edited to define the voltage at the lowest operating point of travel. For CW actuator configuration, this voltage should be 1.3 V and for CCW configuration, 3.7 V. The DCM-2 will automatically adjust when the direction of travel is changed.
- 5 CPS Span:** Displays the voltage signal span from the CPS-4 for maximum possible rotation of the output shaft. This is the upper range voltage minus the lower range voltage (typically 2.4 V). Not editable.
- 6 CPS RngLwr:** Displays the CPS-4 voltage signal at the lowest possible point of travel. Not editable.
- 7 CPS RngUpr:** Displays the CPS-4 voltage signal at the highest possible point of travel. Not editable.
- 8 Pos S/N:** Displays the Serial number of the CPS-4 and has no effect on actuator function.
- 9 Snsr Dir:** The direction of output shaft rotation that causes the CPS-4 signal to increase. This direction is typically CW and is not editable.

MENU 4D -- Demand Setup

The parameters on this menu determine the range and characterization of the Demand signal. It also includes parameters that determine behavior when the Demand signal is absent.

1 DemRngLwr: Sets and displays the signal value in mA that represents 0% Demand (default is 4.00 mA, minimum is 0.5 mA). This value should be set above "DemLimLwr".

2 DemRngUpr: Sets and displays the signal value in mA that represents 100% Demand (default is 20.00 mA, maximum is 21.00 mA). This value should be set below "DemLimUpr".

3 Dem Curve: Determines the relationship between the Demand signal and the position of the output shaft. Typically set to Linear, but may also be set to Square, Square Root or customized Special Curve.

4 Dem Curve Spcl: Link to the "Dem Curve Spcl" menu.

5 LOS Mode: Action on loss of Demand signal.

6 LOS Pos: If the "LOS Mode" has been set to "Go-to-Pos", this defines where the output shaft will move (in percent of travel) during loss of Demand signal conditions.

7 DemLimLwr: Sets the threshold (in mA) below which the Demand signal is considered lost. This value should be set below "DemRngLwr".

8 DemLimUpr: Sets the threshold (in mA) above which the Demand signal is considered invalid. The Demand alarm will activate until the signal is brought below this level. This value should be set above "DemRngUpr".

MENU 5A -- Dem Curve Spcl

This menu allows setting the Demand signal characterization curve.

MENU 4E -- Feedback Setup

This menu is where all the Feedback signal related actuator parameters are set.

1 FBRngLwr: The value of the Feedback signal (in mA) that corresponds to a 0% output shaft position. This value can range between 3.00 mA and 16.00 mA (default = 4.00 mA).

2 FBRngUpr: The value of the Feedback signal (in mA) that corresponds to a 100% output shaft position. This value can range between 7.00 mA and 21.00 mA (default = 20.00 mA).

3 Feedback: Enables or Disables the Feedback signal.

4 FB Curve: Allows a choice in the relationship between the applied Feedback signal and the actual position of the actuator. Choices are: Linear & Inverted Demand ("InvDem").

APPENDIX: HART[®] COMMUNICATION

MENU 4F -- Torque Setup

This menu is where all the Torque related actuator parameters are set.

- 1 Trq/Thrust:** Enables or disables torque sensing.
- 2 Ovt Prot:** Enables or disables overtorque protection which will remove power from the motor if excessive torque is detected.
- 3 AlarmLevel:** Sets the value that, if exceeded, will cause the Torque Alarm to activate (20–105%).
- 4 ShutDwnTrq:** Sets the output shaft torque in percentage of actuator rating that, if exceeded, removes power from the motor (25–115%).
- 5 Trq Null:** The torque sensor value that represents 0% output shaft torque. This value is unique for each actuator and may be found on a label inside the DCM compartment.
- 6 Trq Const:** The internal DCM-2 signal span associated with the output shaft torque. This value is determined during manufacture and is noted on a label inside the DCM compartment.

MENU 3D -- Statistics

This menu is where all the actuator's stored operating statistics are available.

- 1 Starts:** The total number of motor starts.
- 2 Reversals:** The total number of times the motor has started in the direction opposite to the previous start.
- 3 Stalls:** The total number of times the stall time has been exceeded.
- 4 OverTorques:** The total number of times that excessive torque was detected at the output shaft.
- 5 Pk Torque:** The highest recorded torque on the output shaft.
- 6 TotRunTm:** Total amount of time the motor has been powered (in seconds).
- 7 High Temp:** Highest temperature recorded in the DCM-2 compartment (in degrees fahrenheit).
- 8 Low Temp:** Lowest temperature recorded in the DCM-2 compartment (in degrees fahrenheit).

MENU 3E -- Manual Operation

This menu is used to allow manual operation using HART[®] communications. There are three manual operation procedures available:

- 1 Op mode (Menu 4G):** Selects the operating mode of the DCM-2. There are six possible choices: "Follow", "Hold", "RunCW", "RunCCW", "Stay" and "Stop". "Follow" mode is the normal state of operation and allows the DCM-2 control in response to the analog input Demand signal. "Hold" mode forces the DCM-2 to position according to the HART Demand value (see right). "RunCW" mode forces the actuator to move CW. "RunCCW" forces the actuator to move CCW. The "Stay" mode forces the actuator to maintain its present position. Note that in "Stay" mode, the Handwheel cannot be freely turned. The "Stop" mode removes power from the motor. Note that in "Stop" mode the Handwheel can be freely turned. Note that the Handswitch overrides all operating modes.
- 2 Demand:** This procedure sets the effective Demand signal. If "Op mode" is set to "Hold", entering a valid value (-5% to 105%) will control the motor. If "Op mode" is set to "Follow", the analog Demand signal is displayed (unless an alarm condition exists).
- 3 Reset Stall:** This procedure resets normal actuator operation after a stall condition has caused the motor to shut down. Note that stall conditions can also be reset by simply reversing the input Demand signal or cycling the actuator AC power.

MENU 3F -- Diagnostics

Provides paths to menus that allow investigation of actuator problems through status indicators, self-test routines, output shaft loading history, alarm setup and setting of the DCM-2 real time clock. Menu item links are "Status", "Tests", "CW Torque", "CCW Torque", "Alarm Setup", and "RealTimeClock".

MENU 4H -- Status

This menu provides links to menus that monitor the operational status of the actuator. It also displays one parameter, line frequency.

- 5 Line Freq:** The power line frequency as measured by the DCM-2.

MENU 5B -- LED Status

The LED Status parameter allows remote checking of which LEDs on the DCM-2 are illuminated.

MENU 5C -- Operating Status

The Operating Status parameter is a summary of whether process-related conditions are inside or outside of anticipated limits. These conditions control the Status Indication LEDs. Each parameter is listed with an ON or OFF state. The ON state is described below.

- 1 Dem <> Limits:** Caused by the Demand signal falling below or above acceptable levels.
- 2 Pos <> Limits:** Caused by the CPS-4 signal being outside the range anticipated by the DCM-2.
- 3 Temp <> Limits:** The ambient temperature of the DCM-2 is outside of the rating.
- 4 Torq <> Limits:** Measured torque exceeds the configured alarm level.
- 5 Over Torq Stop:** Overtorque protection is preventing the DCM-2 from running the motor.
- 6 Stalled:** A Stall alarm is active.
- 7 Feedback Open:** The Feedback signal is enabled, but cannot follow the proper current.
- 8 Switch Block:** The DCM-2 cannot power the motor due to an electro-mechanical switch. Check the Handswitch and over-travel limit switches.

MENU 5D -- Switch Status

Each parameter will be listed with an ON or OFF state. The ON state is described below.

Limit CCW: The CCW over-travel limit switch has been reached.

Limit CW: The CW over-travel limit switch has been reached.

OvrRd CCW: The CCW manual override terminal (20) is shorted to the common (18).

OvrRd CW: The CW manual override terminal (19) is shorted to the common (18).

OvrRd STOP: The STOP manual override terminal (21) is shorted to the common (18).

HndSw CCW: The handswitch is in the CCW position.

HndSw CW: The handswitch is in the CW position.

HndSw AUTO: The handswitch is in the AUTO position.

MENU 5E -- Local Cntrl Status

This parameter allows remote monitoring of which buttons on the local configuration interface are being pressed.

MENU 5F -- CW Inhibitors

Allows viewing of the DCM-2 condition that is preventing the actuator motor from running in the CW direction.

MENU 5G -- CCW Inhibitors

Allows viewing of the DCM-2 condition that is preventing the actuator motor from running in the CCW direction.

MENU 4I -- Tests

This menu provides access to some routines that help determine if the actuator is functioning properly.

- 1 FB Out Test:** Allows manual verification of the Feedback output signal to check operation and accuracy.
- 2 Board Self-Test:** Instructs the DCM-2 to check various power and sensing circuits. This test will cause the actuator to reposition, so it should be run offline and only when a DCM-2 problem is suspected.
- 3 Identify Device:** Causes the ACKNOWLEDGE LED on the DCM-2 to flash for two seconds. Ensures the HART system is addressing the correct actuator.
- 4 Board Reset:** Causes the DCM-2 to initiate a reset cycle similar to a power-up reset. This manual reset will cause the actuator to reposition. This procedure is not typically necessary.

MENU 4J -- CW Torque

This menu displays the peak output shaft torque measured for 10 segments. These torque values are measured with the motor running and moving the output shaft CW.

MENU 4K -- CCW Torque

This menu displays the peak output shaft torque measured for 10 segments. These torque values are measured with the motor running and moving the output shaft CCW.

APPENDIX: HART[®] COMMUNICATION

MENU 4L -- Alarm Setup

The Alarm Setup menu parameters allow modification of the behavior of the alarm.

- 1 **AlarmPol:** Whether the solid state relay opens on alarm or closes on alarm.
- 2 **Alarm Mask:** Link to the Alarm Mask menu which allows specific alarm conditions to be ignored.

MENU 5H -- Alarm Mask

Allows selection of alarm conditions that will not cause an alarm at terminal E.

MENU 4M -- RealTimeClock

This menu allows the date and time to be set.

- 1 **RTC Day:** Day of the month (numeric value).
- 2 **RTC Month:** Month (numeric value).
- 3 **RTC Year:** Year (4 digits).
- 4 **Hour (24):** Hour of the day (24 hour format).
- 5 **Minute:** Minute of the hour (0 through 59).

MENU 3G -- Calibration Trim

The Calibration Trim menu sets and displays actuator calibration values. **Note that changing the calibration trim can cause signal measurement difficulties if performed improperly.**

- 1 **PresCPS V:** Displays and/or trims the present voltage of the position signal. This value may also be measured at DCM-2 test points TP1(-) and TP4(+). This trim is set and tested at the factory. Changing this value can cause voltage measurement errors.
- 2 **Loop(Dem):** Displays the Demand signal as measured at the field wiring terminals (14 & 15). When the Demand control loop signal is being overridden by a special mode of operation, the effective Demand will not correspond to the mA value. This value can be edited to trim the Demand to ensure accurate measurement of the analog signal. Demand can only be trimmed at 4.0 mA and 20.0 mA.
- 3 **Feedback:** Displays the mA signal representing the output shaft position as measured at the field wiring terminals (16 & 17). This value can be edited.
- 4 **Trq/Thrust:** Displays the load measured at the output shaft as a percentage of rated torque. This is also a short cut to set the 0% torque parameter ("Trq Null") by removing load from the output shaft, then setting this value to "0".

APPENDIX: HART[®] MESSAGES

COMMON HART[®] MESSAGES

HART[®] protocol maintains both standard and device specific informational messages that are displayed on the Communicator when various conditions occur.

Below is a table of typical Beck actuator messages and message sequences. It does not include all possible messages, only the most common followed by a brief description.

Output Shaft Position Measurement Messages

Message	Description
"Process applied to the primary variable is outside the operating limits of the field device."	This is a standard HART-defined message that appears whenever the Position signal from the CPS-4 is outside the design or calibrated range. This message should be accompanied by a Beck-specific message with more detail.
"The Position Signal is less than -5% or greater than 105%."	This Beck-specific message indicates the DCM-2 is reading a CPS-4 Position signal not within the calibration range limits.
"Position signal in LOS."	This is a Beck-specific message. The DCM-2 is indicating that the Position signal is a problem and is intended to identify a CPS-4 or wiring failure. This is triggered when the Position signal is outside the minimum and maximum voltage limits.
"Position out of accurate measurement range."	This is a Beck-specific message. The DCM-2 indicates the CPS-4 Position signal is outside of the design range.
"Position sensing error."	This is a Beck-specific message. The DCM-2 circuitry for measuring the Position signal does not appear to be functioning properly.
"Analog output 1 and its digital representation are outside the operating range limits, and not responding to input."	This is a standard HART-defined message that appears whenever the position signal to the DCM-2 is outside the design or calibrated range. This message should be accompanied by a Beck-specific message with more detail.

Handswitch and Over-travel Limit Switch Message

Message	Description
"Motor power is blocked, check switches."	This message will appear if the DCM-2 detects a condition that prevents current flow to the motor.

Stall Protection Message

Message	Description
"Stall condition has been detected (see 'Stall Time' in the 'General Setup' menu 4B)."	This is a Beck-specific message indicating that the actuator is in a stalled condition. This occurs if the actuator cannot reach the Demand position in the time allotted by the stall time setting (configurable from 30–300 seconds).

APPENDIX: HART[®] MESSAGES

Demand, Torque and Temperature Measurement Messages

Message	Description
"Process applied to the non-primary variable is outside the operating limits of the field device."	This is a standard HART-defined message that appears whenever the Demand signal or Temperature are outside their design or calibrated ranges. This message should be accompanied by a Beck-specific message with more detail.
"The Demand Signal is outside of the intended limits (see Demand Setup menu 3C)."	This Beck-specific message indicates the Demand signal is invalid.
"Demand out of accurate measurement range."	This is a Beck-specific message that the Demand signal is not only out of the calibrated range, but also out of the design range of the actuator. The lower and upper limits are 0.1 V dc and 5.5 V dc, respectively. Note that current input DCM-2 boards utilize a 250 Ohm input resistor to convert the current signal to voltage.
"Demand Signal is out of limit."	This Beck-specific message indicates the Demand signal is too high to measure accurately. The upper limit is 5.5 V dc. Note that current input DCM-2 boards utilize a 250 Ohm input resistor to convert the current signal to voltage.
"Demand sensing error."	This is a Beck-specific message. The Demand sensing circuitry does not appear to be functioning properly.
"The Torque/Thrust is greater than the output rating."	This Beck-specific message defines an output shaft torque overload problem.
"Motor power has been removed due to excessive output torque."	This Beck-specific message indicates the DCM-2 has removed power from the motor due to excessive output shaft torque load. The Handswitch must be in AUTO mode for this alarm to be accurate.
"Torque/Thrust out of accurate measurement range."	This is a Beck-specific message. The DCM-2 is not able to read a valid signal from the Torque sensor. Check the torque sensing cable.
"Torque/Thrust sensing error."	This is a Beck-specific message. The DCM-2 circuitry for measuring the Torque signal does not appear to be functioning properly. Check the torque sensing cable.
"The temperature is outside of -40°F to 185°F."	This is a Beck-specific message indicating that the temperature at the DCM-2 is outside of the acceptable range.
"Temperature out of accurate measurement range."	This is a Beck-specific message. The DCM-2 ambient temperature reading is extreme and cannot be accurately measured.
"Temperature A/D Fail."	This is a Beck-specific message. The DCM-2 circuitry for measuring the ambient temperature does not appear to be functioning properly.
"The Feedback Signal is enabled but the loop is open."	This is a Beck-specific message indicating that the Feedback sourcing circuit is unable to create the proper signal current. This message could result from the signal not being wired to an external load, or a wiring failure has occurred at some point between the actuator and the monitoring device.

Questionable Configuration Messages

Message	Description
"Analog output 1 and its digital representation are in fixed mode, and not responsive to input changes."	Standard HART-defined message that appears whenever the Feedback signal has been manually assigned a value. This message should be accompanied by a Beck specific message with more detail.
"Feedback is in fixed mode."	A Beck-specific message indicating that the Feedback signal has been manually set to a fixed value and is not following the Position value.
"Local control button pressed while locked-out."	A Beck-specific message indicating an incorrect combination of pushbuttons is being pressed on the local configuration interface, or the local control interface is disabled and a pushbutton is being pressed.
"Loop Current Detected while under HART/FF Control."	A Beck specific alarm message that alerts the user that analog current is present on the Demand terminals, but the DCM-2 is in an Op Mode expecting digital control. Make certain the Op Mode parameter is set properly.
"Loop Current Detected while set for LOS PAT."	A Beck specific alarm message that alerts the user that analog current is present on the Demand terminals, but the DCM-2 is set to a LOS mode intended to be used without an analog signal.

DCM-2 Failure Messages

Message	Description
"Real-time Clock hardware failure."	This is a Beck-specific message. The data in the Real-time Clock appears invalid.
"FRAM Memory has failed."	A Beck-specific message. The continuous built-in self-test cannot verify the memory for statistics information is operating properly.
"Memory failure."	This is a Beck-specific message. The continuous built-in self-test cannot verify the microcomputer is operating properly.

Miscellaneous HART-Defined Messages

Message	Description
"Field device has more status available."	This is a standard HART-defined message that appears whenever an alarm or other undesirable status exists. This is the HART protocol mechanism for displaying the other messages in this section. If this message is displayed without an additional message, the status cleared before HART read the additional status.
"A reset or self-test of the field device has occurred, or power has been removed and reapplied."	This message is presented if the DCM-2 has gone through a power-up reset sequence since the last communication with the master. This message is only displayed once after a reset.
"A modification has been made to the configuration of the field device."	This message indicates that the DCM-2 has undergone a configuration change since the last time the HART master has reset the change flag. Many HART masters disregard the flag and do not report this message.
"Field device has malfunctioned due to a hardware error or failure."	This message indicates that the continuous built-in self-test cannot verify the microcomputer is operating properly.

APPENDIX: SERIAL COMMUNICATION

COMMUNICATIONS

Local configuration of the Beck actuator can be accomplished using Serial commands through the DCM-2 Serial port.



CAUTION

Changes made to the actuator through Serial communications may not necessarily be reflected in asset management systems. Be sure to verify any changes made serially and make manual corrections to the asset management system if necessary.

The Beck Digital Control Module (DCM-2) is equipped with a Serial interface which allows for direct communication with a computer. Using a communication cable (see illustration on page 63), connect the DCM-2 to the computer using the DCM-2's RS-232 (J20) connector (see page 23 for port location) and the computer's COM port. Ensure that the COM port on the computer is active, and that the cable is plugged into the proper COM port if more than one is present (e.g., COM1, COM2, etc.). Note that a plug end adapter may be necessary for connection to the computer's COM port.

Once connected, communication can be established between the DCM-2 and the computer using a terminal emulation program, such as HyperTerminal®. This method of communication will allow for configuration, calibration and verification of actuator DCM-2 settings without the use of custom software applications.

HyperTerminal® SOFTWARE

HyperTerminal is the standard ASCII terminal emulation software provided with Microsoft® Windows®. If using HyperTerminal®, the following instructions will assist in setup and assume use of the Beck Serial cable (see following page). Note that some variation to these instructions may be necessary depending on the version of HyperTerminal® being used.

The RJ-11 connector (on the Beck Serial cable) should be attached to the RS-232 port on the DCM-2 (see page 23). The other end of the Beck Serial cable (the DB-9 connector) should then be plugged into a windows-based computer. Some computers may require a Serial adaptor such as a USB/Serial converter to communicate.

Access HyperTerminal® by clicking first on "Start", then "Programs", then "Accessories", then "Communications", then "HyperTerminal". Double-click on the "Hypertrm.exe" icon to start the program. Once HyperTerminal® is running, it is necessary to set up a file with the proper settings to communicate with the DCM-2. Proceed as follows:

1. If prompted to install a modem, answer "no". Proceed to enter a name (e.g., "DCM-2") and select an icon (any will suffice) in the "Connection Description" box. Click the "OK" button.
2. The "Connect to" box should open next. At the bottom of the box, set the "Connect using" selection to the computer COM port that has been connected to the DCM-2. Click the "OK" button.
3. The COM port properties box should open next; this is where the communication settings are established. The correct settings are:
 - a. Bits per second = "1200"
 - b. Data bits = "8"
 - c. Parity = "none"
 - d. Stop bits = "1"
 - e. Flow control = "none"
4. With the appropriate settings entered from Step 3, above, click "OK". Communications should now be enabled.
5. Press the "Enter" key twice. "OK" should be displayed indicating that HyperTerminal® is communicating with the DCM-2.

APPENDIX: SERIAL COMMANDS

COMMANDS AND ARGUMENTS

Commands can be used for a variety of functions including changing the operating configuration of the actuator, verifying operation settings, calibration and accessing diagnostic information. There are essentially four different types of commands:

1. Dual-purpose commands. These commands can be used to either modify actuator configuration settings or display existing actuator settings. In order to set or make a change to the settings, the command requires an argument (*n*). If the command is used for display purposes only, the argument is omitted. Examples of these commands include "temperature" and "demlos".
2. Display only commands. These commands are used to display diagnostic or operating information such as present signal values. No arguments are required. Examples include the "stat" command and the "signals" command.
3. Set only commands. These commands serve only to make a parameter change. Typically, they apply to the actuator calibration. This type of command requires an argument, but unlike dual-purpose commands, they return an error message when entered without an argument. Examples include the "charset" and "trimfdbk4mA" command.
4. Execute action commands. These commands serve to reset, enable or disable features. Entering these commands produces an immediate action. Examples include the "reset" and "restoremodes" command.

The available commands are listed on the next several pages and each is described in detail. The command description explains the use or uses of the command, while the argument column describes any applicable arguments. Arguments are denoted as *n*. Note that the commands described as "sets and/or displays" signify dual-purpose commands that can be used with or without an argument for setting or verifying configuration settings.

Beck Serial Cable Pinout Table

RJ-11 6-PIN PLUG PIN NO.	DB-9 9-PIN PLUG PIN NO.
1	8
2	2
3	9
4	5
5	3
6	7

**Beck Serial Cable Illustration
(Part Number 20-0511-13)**

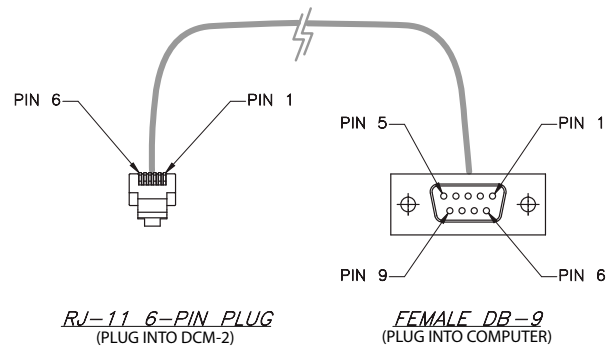

APPENDIX: SERIAL COMMANDS

SERIAL COMMANDS

The following is a categorized list of Serial commands available through the RS-232 interface. These commands are described in detail on the pages that follow.

Output Shaft Position Sensing Commands

cpsvat0pct	travel
------------	--------

General Configuration Commands

alarmout	opmode
alarmoutmask	restoremodes
configformodel	sernum
drvdir	stallprot
drvtiming	stalltime
limitalarm	stepsize
gearratio	

Torque Sensing Commands

ovtstop	torq100pct
ovtstoplevel	torqalarm
torq	torqconst
torq0k	torqenable
torq0pct	torqprof

HART® Configuration Commands

harttype	polladdr
----------	----------

Diagnostic and Information Commands

demsource	signals
help	stat
ledtest	temperature
reset	uninstall

Demand Signal Commands

dem0pctma	demlostgtp delay
dem100pctma	trimdem4ma
demlos	trimdem20ma
demlostgtp	

Demand Characterizer Commands

charclear	charset
charlist	demfunc

Feedback Signal Commands

fdbk0pctma	trimfdbk4ma
fdbk100pctma	trimfdbk20ma
fdbkfunc	iomode

Output Shaft Position Sensing Commands

Command	Description	Argument <i>n</i> and Information
cpsvat0pct <i>n</i>	Sets/displays the DCM-2 voltage setting used to determine 0% signal from the CPS-4. Voltage is dependent upon the actuator model. Typically, this setting does not need to be changed.	<i>n</i> = desired voltage as a decimal (carried out to 3 decimal places). The standard signal setting is approx. 1.3 V.
travel <i>n</i>	Sets/displays the number of degrees that represents 100% travel. This command does not shift the 0% position; when increasing travel from a reduced travel setting, the 0% position may need to be changed first to keep travel within acceptable end points. The end points are defined by the CPS-4 voltage range.	<i>n</i> = desired length of travel in degrees. This value cannot exceed the maximum output shaft rotation of the actuator.

General Configuration Commands

Command	Description	Argument <i>n</i> and Information
alarmout <i>n</i>	Sets/displays the polarity of the alarm output solid state relay.	<i>n</i> = "0": open on Alarm <i>n</i> = "1": closed on Alarm Upon loss of power, the relay is open regardless of the setting.

General Configuration Commands (cont'd)

Command	Description	Argument <i>n</i> and Information
alarmoutmask <i>n</i>	Sets/displays (in hexadecimal format) which conditions will cause an alarm: 0x00000001 - Demand Loss of Signal 0x00000002 - Torque High 0x00000004 - Stall Condition 0x00000008 - Torque Stop 0x00000010 - Stop/Limit 0x00000020 - Feedback Loss of Signal 0x00000040 - Temperature too High/Low 0x00000080 - Position Outside of Limits 0x00000100 - Real-time Clock Failure 0x00000200 - Torque Measurement Failure 0x00000400 - Position Analog/Digital Circuit Failure 0x00000800 - Demand Measurement Failure 0x00002000 - Position Loss of Signal 0x00004000 - Temperature Measurement Failure 0x00008000 - Memory Failure 0x00010000 - Invalid Button Pressed 0x00020000 - Demand too High	<i>n</i> = "0x0": no listed condition causes a status alarm <i>n</i> = "0xffffffff": all listed conditions cause a status alarm <i>n</i> = hexadecimal value for specific condition(s) which will cause an alarm. Multiple conditions may be selected by performing a hexadecimal addition of the condition values; e.g., Stall Condition and Torque Stop alarms -- hex 0x04 + 0x08 = 0x0C.
configformodel <i>n</i>	Sets certain DCM-2 default values based on the actuator Serial number. These values are direction rotation for an increasing CPS-4 signal, expected range of CPS-4 signal and the maximum travel.	<i>n</i> = "1": executes command
drvdir <i>n</i>	Sets/displays the actuator output shaft rotation direction resulting from an increasing Demand signal.	<i>n</i> = "0": CW rotation <i>n</i> = "1": CCW rotation
drvtiming <i>n</i>	Sets/displays number of seconds the actuator takes to travel from 0% to 100%. Also indicates frequency of motor voltage as provided by the DCM-2.	<i>n</i> = seconds
gearratio <i>n</i>	Sets/displays the gear ratio from the motor to the output shaft.	See pages 7 & 9 for <i>n</i> value (gear ratio) appropriate for the actuator model and stroke timing.
limitalarm <i>n</i>	Sets/displays alarm action if the actuator travels outside of the electronic limits and contacts an over-travel limit switch.	<i>n</i> = "0": mute (no alarm) <i>n</i> = "1": always
opmode <i>n</i>	Sets/displays the mode that controls the Demand signal source. This mode selects analog or digital control.	<i>n</i> = "0": analog Demand <i>n</i> = "1": digital Demand <i>n</i> = "2": run CW <i>n</i> = "3": run CCW <i>n</i> = "4": stay <i>n</i> = "5": stop
restoremodes <i>n</i>	Returns the DCM-2 settings to the original factory configuration.	<i>n</i> = "1": executes command
sernum <i>n</i>	Sets the actuator serial number.	<i>n</i> = serial number
stallprot <i>n</i>	Sets/displays stall protection state.	<i>n</i> = "0": disabled <i>n</i> = "1": enabled
stalltime <i>n</i>	Sets/displays time the actuator runs in one direction before stall alarm is activated.	<i>n</i> = seconds: acceptable range is 30–300 seconds.
stepsize <i>n</i>	Sets/displays the size of one incremental movement of the output shaft.	<i>n</i> = % of travel desired: acceptable range is 0.10%–2.5%. Include "%" symbol after number, otherwise the unit of measure will be degrees.

APPENDIX: SERIAL COMMANDS

Torque Sensing Commands

Command	Description	Argument <i>n</i> and Information
ovtstop <i>n</i>	Sets/displays whether motor power will be removed during severe overtorque conditions. Torque sensing must be enabled.	<i>n</i> = "0": disabled <i>n</i> = "1": enabled
ovtstoplevel <i>n</i>	Sets/displays the torque magnitude associated with severe output shaft torque conditions.	<i>n</i> = allowable torque magnitude (without stopping motor) in percentage of actuator rating. May be set from 25% to 115% (factory set to 115%).
torq	Displays the measurement of the torque on the output shaft as a percentage of actuator rating. Also displays related values such as torq0k and torqconst.	No argument.
torq0k <i>n</i>	Sets/displays the value of DCM-2 internal measurement corresponding to 0% torque on the output shaft.	<i>n</i> = the zero torque value in counts (noted on label inside DCM-2 cover).
torq0pct <i>n</i>	An alternate method for setting torq0k. Useful when the correct torq0k value is not known. To use this command, remove all load from the output shaft, then execute torq0pct with argument "0" to let the DCM-2 know that the torque sensing should be reading 0%.	<i>n</i> = "0"
torq100pct <i>n</i>	An alternate method for setting torqconst. Useful when the correct torqconst value is not known, but the exact output torque is known. To use this command, load the output shaft with an exact load, preferably 100%. Execute torq100pct to let the DCM-2 know what the torque sensing should be reading.	<i>n</i> = exact output shaft torque as a percent of rated load of the actuator.
torqalarm <i>n</i>	Sets and/or displays the torque magnitude associated with the first level of alarm.	<i>n</i> = allowable torque magnitude without alarm, in percentage of actuator rating. May be set from 20% to 105%.
torqconst <i>n</i>	Sets/displays the value of DCM-2 internal measurement corresponding to the torque span (the measurement at 100% minus the measurement at 0%).	<i>n</i> = the torque span value in counts (noted on label inside DCM-2 cover).
torqenable <i>n</i>	Sets/displays the status of torque sensing (enabled or disabled).	<i>n</i> = "0": disabled <i>n</i> = "1": enabled
torqprof	Displays a three table column: 1. Maximum travel divided into 10 segments 2. Peak torque measured in each segment with motor running CW 3. Peak torque measured in each segment with motor running CCW	No argument.

HART® Configuration Commands

Command	Description	Argument <i>n</i> and Information
harttype <i>n</i>	Sets/displays the DCM-2 HART DD (Device Description). "239" is the proper DD; other DDs are for temporary use if the new DD is not available.	<i>n</i> = "1": ESR-D <i>n</i> = "10": Beck DCM <i>n</i> = "239": Beck MK2
polladdr <i>n</i>	Sets/displays the polling address used by the HART master to find individual devices if the HART bus has more than one device.	<i>n</i> = polling address number between "0" and "15"). Unless multiple HART devices are connected in parallel on a single bus, polling address should be "0".

Diagnostic and Information Commands

Command	Description	Argument <i>n</i> and Information
demsources	Provides a readout of information regarding the Demand on the actuator including the source of the Demand signal (Handswitch, demlos or Analog I/P), mode (follow, hold, CW, CCW, Stay or Stop), currently applied Demand signal as a %, the Demand function (linear, square root, square, or special), and the Demand out as a % (dem out shows the signal adjusted when using a non-linear Demand function (demfunc command)).	No Argument
help <i>n</i>	Displays help text for a specific command or lists all available Serial commands.	<i>n</i> = command name <i>n</i> = "all"
ledtest <i>n</i>	Tests the functionality of the DCM-2 LEDs individually or as a group. If "all" is selected, the command will consecutively cycle through each LED twice. If an individual LED is selected, it will flash 12 times.	<i>n</i> = "1": DEMAND <i>n</i> = "2": POSITION <i>n</i> = "3": TRQ/THRUST <i>n</i> = "4": STALL <i>n</i> = "5": TEMP °F <i>n</i> = "6": FB OPEN <i>n</i> = "7": UVOLT <i>n</i> = "8": ACKNOWLEDGE <i>n</i> = "100": FWD <i>n</i> = "101": REV <i>n</i> = "102": STAT <i>n</i> = "All"
reset <i>n</i>	Performs the same reset sequence as when power is removed and reapplied.	<i>n</i> = "1": must equal "1" for command to execute.
signals	Displays the present DCM-2 readings of four signals: Position signal from CPS-4 Demand Feedback Torque	No argument = signal readings are displayed. <i>n</i> = "all": an extended set of data is displayed.
stat	Displays information on the status of the actuator, including: Time / Date, Demand, Position, Error (Demand minus Position), Step size, Dead band, Motor Status, Motor Run Time, Line Frequency, Motor Starts, Motor Reversals/Stalls, Number of Overtorque conditions, Positive & Negative Peak Torque (%), CW and CCW Inhibitor Status, Alarms	No argument
temperature <i>n</i>	Displays three values describing the ambient temperature in the actuator. Low extreme, present, high extreme. Can also change the temperature units.	No argument = temperatures are displayed. <i>n</i> = "F": changes units to Fahrenheit <i>n</i> = "C": changes units to Celsius
unstall	Resets the Stall Protection alarm to restore power to the motor. If the motor remains physically stalled, the Stall Protection alarm will recur.	No argument.

APPENDIX: SERIAL COMMANDS

Demand Signal Commands

Command	Description	Argument <i>n</i> and Information
dem0pctma <i>n</i>	Sets/displays the Demand signal value that corresponds to 0% actuator position.	<i>n</i> = Demand signal as a decimal in mA. Minimum value is 0.50; maximum value is 100% Demand less 4.00 mA (e.g., if 100% Demand is 20.00 mA, the 0% value must be set for 16.00 mA or less).
dem100pctma <i>n</i>	Sets/displays the Demand signal value that corresponds to 100% actuator position.	<i>n</i> = Demand signal as a decimal in mA. Minimum value is 0% Demand plus 4.00 mA (e.g., if 0% Demand is 4.00 mA, the 100% value must be set for 8.00 mA or greater). Maximum value is 21.00 mA.
demlos <i>n</i>	Sets/displays the Demand signal threshold, below which the DCM-2 recognizes the signal has been lost. The threshold is entered as a value in mA. This command also sets/displays the action initiated by the actuator during LOS (Loss Of Signal). LOS action options are "sip" (stay in place) or "gtp" (go to position). Demlos always reports both settings, but only sets one argument at a time. Demlos must be used twice to set both the threshold and action.	<i>n</i> = Demand signal in mA below which LOS occurs (e.g., the typical value for a 4–20 mA system is 3.20). -OR- <i>n</i> = "sip", "gtp" or "pat". The "pat" argument acts the same as "sip", but also suppresses the alarm-- this is used in some pulsed applications.
demlogtp <i>n</i>	Sets/displays the position to which the actuator will run upon loss of the Demand signal (LOS). This command has no effect if the actuator is set to "sip" (stay in place).	<i>n</i> = desired position of actuator expressed as a percentage of actuator travel in decimal form (e.g., 50% = 50.00).
demlogtp delay <i>n</i>	Sets the time delay in seconds before the actuator will move to the position set in "demlogtp". Entering this command without an argument will return the present gtp and delay settings.	<i>n</i> = time delay in seconds. Acceptable values are 0 (default) to 25.5.
trimdem4ma 4	Trims the Demand analog-to-digital sensing circuit to be accurate at 4 mA. This command should only be used when the Demand signal at the actuator is exactly 4.0 mA. Trim is factory set and should not normally require recalibration.	"4" is the only acceptable value; this trim can only be performed at 4 mA.
trimdem20ma 20	Trims the Demand analog-to-digital sensing circuit to be accurate at 20 mA. This command should only be used when the Demand signal at the actuator is exactly 20.0 mA. Trim is factory set and should not normally require recalibration.	"20" is the only acceptable value; this trim can only be performed at 20 mA.

Demand Characterizer Commands

Command	Description	Argument <i>n</i> and Information
charclear <i>n</i>	Clears a preconfigured Demand characterizer curve node by setting it to "unused". Any node numerically higher will be set to "unused" also.	<i>n</i> = node number: between 1 and 21.
charlist <i>n</i>	Displays the X-values and Y-values of Demand characterizer curve node(s).	<i>n</i> = node number: between 1 and 21. <i>n</i> = "all": displays all nodes
charset <i>n1, n2, n3</i>	Sets the X-values and Y-values of a specific node of the characterizer curve. The three arguments must be separated by commas.	<i>n1, n2, n3</i> = (<i>n1</i> is node number to modify, <i>n2</i> is X-value as a percentage, <i>n3</i> is Y-value as a percentage)
demfunc <i>n</i>	Sets/displays the Demand signal characterization function.	<i>n</i> = "0": linear <i>n</i> = "1": square root <i>n</i> = "4": special curve <i>n</i> = "5": square

Feedback Signal Commands

Command	Description	Argument <i>n</i> and Information
fdbk0pctma <i>n</i>	Sets/displays the mA value of the Feedback signal that represents the 0% output shaft position. May also be set for decreasing direction of Feedback. See page 36.	<i>n</i> = desired Feedback signal in mA at 0% output shaft position. Minimum value is 3.00 mA and the maximum must be at least 4.00 mA less than the Feedback signal value for the 100% output shaft position.
fdbk100pctma <i>n</i>	Sets/displays the mA value of the Feedback signal that represents the 100% output shaft position. May also be set for decreasing direction of Feedback. See page 36.	<i>n</i> = desired Feedback signal in mA at 100% output shaft position. Minimum value must be at least 4.00 mA greater than the Feedback signal value for the 0% output shaft position. Maximum value is 21.00 mA.
fdbkfunc <i>n</i>	Sets/displays the curve used to calculate the Feedback signal.	<i>n</i> = "0": linear <i>n</i> = "1": inverse Demand (curve enabled)
trimfdbk4mA <i>n</i>	Trims the Feedback signal at 4 mA. Calibrated at the factory, should not normally require calibration.	<i>n</i> = present Feedback signal from the DCM-2 in mA.
trimfdbk20mA <i>n</i>	Trims the Feedback signal at 20 mA. Calibrated at the factory, should not normally require calibration.	<i>n</i> = present Feedback signal from the DCM-2 in mA.
iomode <i>n</i>	Sets/displays the function of a DCM-2 connector pin. May be enabled for Feedback or potentiometer.	<i>n</i> = "0": none <i>n</i> = "1": Feedback enabled <i>n</i> = "2": potentiometer power enabled.

APPENDIX: OPTIONAL DCM-2 W/ FEEDBACK DISPLAY

The DCM-2 Feedback display is an illuminated, numerical readout showing the actuator's position as a percentage of full travel. This display is viewed through a tempered glass window in the electronics compartment. There are also two configurable LEDs visible—a red LED and a green LED.

The DCM-2 display has been calibrated at the factory and should not require any further adjustments.

The display is powered from the Feedback loop current and will not operate until the loop is closed. The Feedback output maximum loop resistance is 500Ω.

The configuration for the Feedback display is 4 mA = 00.0(%) and 20 mA = 100.0(%). By default, the green LED will light when the Feedback is indicated at less than 1(%). The red LED will light when the Feedback is indicated at greater than 99(%).

The illumination points for the LEDs may be modified using a serial command (see next page).

For information on serial communication and commands, see page 62.



**DCM-2 with Feedback Display
Part No. 22-5011-44**



Command	Description	Argument <i>n</i> and Information
<code>ledconfig n1 n2</code>	Changes the point within the position of travel that causes the LEDs to light. May also be used to swap the LED end point assignments (see Example 2, below) or to individually turn off each LED.	<p>n1 = "red": sets the red LED to the n2 argument. "green": sets the green LED to the n2 argument. "inverted": swaps the LED end point assignments (see Example 2, below). "noninverted": sets both LED end points to the default setting (see below).</p> <p>n2 = argument defining position of travel at which the selected LED (n1) will light. Accepts any number representing a valid percentage of travel position. "off": turns off the LED defined in n1.</p>

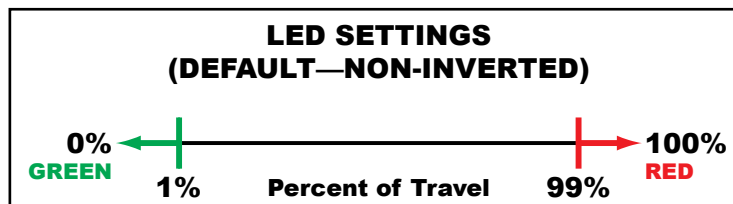

Example 1: Make the "CLOSED" green LED light at 2.0% and the "OPEN" red LED light at 98.0%.

COMMAND	RESULTING LED BEHAVIOR
<code>ledconfig green 2</code> <code>ledconfig red 98</code>	

Example 2: Invert the LED assignments from the default configuration.

COMMAND	RESULTING LED BEHAVIOR
<code>ledconfig inverted</code>	

Example 3: Make the "OPEN" red LED light at 1.0% and greater, and the "CLOSED" green LED light at less than 1.0%.

COMMAND	RESULTING LED BEHAVIOR
<code>ledconfig green 1</code> <code>ledconfig red 1</code>	

NOTE: Both LEDs will not light at the same time; in the event of overlap, the red LED will light.

APPENDIX: OPTIONAL LOCKING HANDSWITCH ---

A locking Handswitch is available for G22 actuators. When installed, the Handswitch may be locked in the AUTO position.



NOTES

INDEX

Appendices	52–69	Loss of Demand Signal (LOS).....	33
HART® Communication	52–58	Maintenance	42–48
HART® Messages	59–61	Component Replacement.....	43
Serial Communication	62	Control End / CPS-4	47–48
Serial Commands	63–69	DCM-2	45–46
DCM-2 with Display	70–71	Fuses	44
Locking Handswitch.....	72	Gaskets	43
Applications Reviews.....	75	Lubrication	43
Auxiliary Limit Switches	27	Motor	43
Setting Switches	27	Recommended Replacement Kits	42
Configuration/Calibration	26–41	Routine	43
Contactless Position Sensor (CPS-4).....	25, 49	Mounting.....	12
Demand Calibration	32	Outline Dimension Drawings	6–9
Demand Characterization Curves	34–35	Position Feedback Signal	36–37
Digital Control Module (DCM-2)	22–25	Power Quality	15
Component Locations.....	23	Precautionary Information	10
Interfaces.....	22	Product Demonstrations	75
Overview LEDs.....	24	Restore Factory Settings	29
Pushbutton Controls	25	Safety Precautions	13
Status Indication LEDs	25	Self-Locking Mechanism (SLM).....	42–43
Direction of Output Shaft Rotation.....	28	Serial Commands	63–69
Electronics	22–25	Serial Communication	62
General Operation Information	11	Services.....	75
General Specifications.....	4–5	Site Surveys	75
Handswitch	11	Spare Parts, Recommended	42
Handwheel.....	11	Specification Writing	75
HART® Communication.....	52–58	Stall Protection	41
HART® Device Description Menu.....	52	Start-up.....	21
HART® Messages	59–61	Step Size	29
How to Obtain Service.....	75	Storage Information.....	10
Installation	12–20	Table of Contents.....	3
Electrical	15	Temperature Sensing	40
Linkage	12–14	Torque Sensing	38–39
Link-Assist™.....	12	Live/Historical Torque	38–39
Mechanical	12–14	Overtorque Alarm	39
Wiring	16–20	Overtorque Protection	39
Introduction.....	2	Travel (Degrees Rotation)	30–31
Limit Switches (Over-travel)	26	Change Travel	31
Setting Switches	26	Troubleshooting.....	49–51
Linkage Kits.....	13	Warranty Statement.....	75

SERVICES

PRODUCT DEMONSTRATIONS

Each of Beck's Sales Engineers has access to a complete set of actuator models so that he can demonstrate virtually any of their features at your location. In order to arrange to see a Beck actuator in your plant or office, contact Beck's Sales Department.

SITE SURVEYS

Beck Sales Engineers are available to discuss your process control requirements. Often a visit to your location is the best way to gain a thorough understanding of your needs, in order to meet them most accurately and completely.

Mounting hardware, torque requirements, linkage, control signal information, and optional equipment can be analyzed most effectively at the work site. Beck's analysis at the job site can help ensure that specifications are accurate, especially in the case of complex applications.

APPLICATION REVIEWS

By sharing your needs with a Beck Sales Engineer you can take advantage of the best application advice for the type of control you need.

This review will yield a better understanding of the versatility of Beck actuators for your installations, as well as complete details on options and accessories to make the process as effective as possible.

SPECIFICATION WRITING

Beck provides specification writing assistance in order to help you specify and order the right actuators for your applications. Beck Sales Engineers will work with you to make it easier for you to obtain the proper equipment and give you confidence that no details are overlooked.

HOW TO OBTAIN SERVICE

Factory repair of actuators or subassemblies is available for both normal and emergency service. To assure prompt processing, contact the factory to receive a Returned Material Authorization (RMA) number. If a repair estimation is desired, please send the name and phone number of your contact for service authorization. It is helpful to include a description of the work desired with the shipment or, in the event of a problem, the malfunction being experienced.

THREE YEAR LIMITED WARRANTY STATEMENT*

Harold Beck & Sons, Inc. (Beck) warrants that our equipment shall conform to Beck's standard specifications. Beck warrants said equipment to be free from defects in materials and workmanship. This warranty applies to normal recommended use and service for three years from the date on which the equipment is shipped. Improper installation, misuse, improper maintenance, and normal wear and tear are not covered.

The Buyer must notify Beck of any warranty issues within 37 months of original shipment date and return the goods in question, at Buyer's expense, to Beck for evaluation. If the product fails to conform to the warranty, Beck's sole obligation and the Buyer's exclusive remedy will be: 1) the repair or replacement, without charge, at Beck's factory, of any defective equipment covered by this warranty, or 2) at Beck's option, a full refund of the purchase price. In no event will Beck's liability exceed the contract price for the goods claimed to be defective.

THIS WARRANTY IS EXPRESSLY IN LIEU OF ANY OTHER EXPRESS OR IMPLIED WARRANTY, INCLUDING IMPLIED WARRANTIES OF MERCHANTABILITY AND FITNESS FOR A PARTICULAR PURPOSE, AND ALL OTHER OBLIGATIONS OR LIABILITIES OF BECK. In no case shall Beck be liable for any special, incidental or consequential damages based upon breach of warranty, breach of contract, negligence, strict tort, or any other legal theory. Such damages include, but are not limited to, loss of profits, loss of revenue, loss of use of the equipment or any associated equipment, cost of capital, cost of any substitute equipment, facilities or service, downtime, the claims of third parties including customers and injury to property.

Buyer acknowledges its responsibilities under OSHA, related laws and regulations, and other safety laws, regulations, standards, practices or recommendations that are principally directed to the use of equipment in its operating environment. Buyer acknowledges that the conditions under which the equipment will be used, its use or combination with, or proximity to, other equipment, and other circumstances of the operation of such equipment are matters beyond Beck's control. **Buyer hereby agrees to indemnify Beck against all claims, damages, costs or liabilities (including but not limited to, attorney's fees and other legal expenses), whether on account of negligence or otherwise, except those claims based solely upon the negligence of Beck and those claims asserted by Beck's employees which arise out of or result from the operation or use of the equipment by Beck's employees.**

*Note: Internal water damage is not covered by warranty.

A 100% EMPLOYEE OWNED COMPANY

BECK

~ founded 1936 ~

SINCE 2021



HAROLD BECK & SONS, INC.

11 TERRY DRIVE • NEWTOWN, PENNSYLVANIA 18940 • USA

PHONE: 215-968-4600 • FAX: 215-860-6383 • E-MAIL: sales@haroldbeck.com

www.haroldbeck.com

Made in USA

