

80-1100-24
Rev. 1.2

MODEL 11-483
11-484

BECK[®]

INSTRUCTION MANUAL



ELECTRIC ACTUATORS FOR INDUSTRIAL PROCESS CONTROL

INTRODUCTION

This manual contains the information needed for the operation and maintenance of the Beck 11-483 multi-turn actuator manufactured by Harold Beck & Sons, Inc. of Newtown, Pennsylvania.

The 11-483 is a rugged, multi-turn addition to the G11 family of actuators and shares the same time-proven reliability, features, and performance advantages. For applications requiring up to 120 lb-ft (163 N•m) of actuator torque, the 11-483 is available with multiple travel span options, ranging from 5 turns to 408 turns.

TABLE OF CONTENTS

Introduction	2
General Specifications	4
Outline Dimension Drawings	6
Precautionary Information	7
Component Location	8
Installation	9
Mechanical	9
Electrical	10
Wiring	11
Start-up	12
Operation	13
Calibration	14
Switches	14
Optional Relay Board	16
Maintenance	17
Routine	17
Component Replacement	18
Spare Parts & Part Numbers	25
Troubleshooting	26
Appendices	27
Optional LED Display	27
Optional Locking Handswitch	28
Index	29
Services	30

GENERAL SPECIFICATIONS

Actuator Power	120 Vac, single-phase, 60 Hz (Standard), 50 Hz (Optional) 208, 240 & 480 Vac, 50 or 60 Hz (Optional)	Allowable Tolerance	+10% -15%		
Maximum Current (Amps) by Supply Voltage					
		Voltage (Vac)			
Model	Maximum Power (VA)	120	208	240	480
11-483	400	3.1	1.8	1.6	.78
Operating Conditions	-40° to 85°C (-40° to 185°F) 0 to 100% relative humidity, non-condensing.				
Direct AC Control	120 Vac for 2-position (11-483) or 3-position (11-484) control.				
Action of Loss of Power	Stays in place.				
Limit Switches	Two SPDT, one for CW and one for CCW limit of travel.				
Auxiliary Switches	Four 6 A, 120 Vac switches. Switches are labeled S1 to S4 and are cam-operated, field adjustable. S1 and S4 are set to operate just before reaching the CCW travel limit. S2 and S3 are set to operate just before reaching the CW travel limit.				
Handswitch	Permits local electrical operation.				
Handwheel	Provides manual operation without electrical power.				
Motor Assembly	120 Vac, single-phase, no-burnout, non-coasting motor has instant magnetic braking. Requires no contacts or moving parts.				
Gear Train	High-efficiency, precision-cut, heat-treated alloy steel and ductile iron spur gears.				
Enclosure	Precision-machined, aluminum alloy castings coated with corrosion-resistant polyurethane paint, provide a rugged, dust-tight, weatherproof enclosure. Actuators designed for hazardous classified locations are also available. Type 4X; IP66/IP68, 3 meters/48 hours*. *Internal water damage is not covered by warranty.				

Output Shaft Rotation

Dependent on the control end (see below).

Control End Assembly (part no.)	Travel Range (turns)
23-2348-10	5–9
23-2348-11	7–14
23-2348-12	14–25
23-2348-13	25–45
23-2348-14	35–70
23-2348-15	65–126
23-2348-16	115–227
23-2348-17	200–408

Mounting Orientation

Any orientaton—no limitations.

Standards

CSA Labeled (US & Canada); CE Compliant; UKCA Compliant

OUTLINE DIMENSION DRAWINGS

MODEL 11-483 SPECIFICATIONS

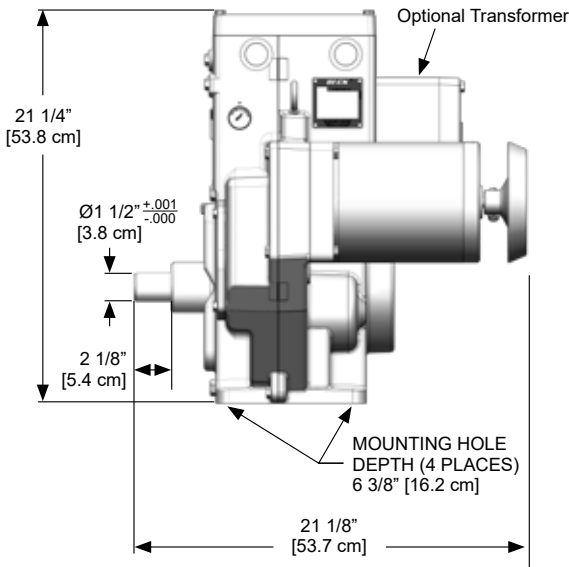
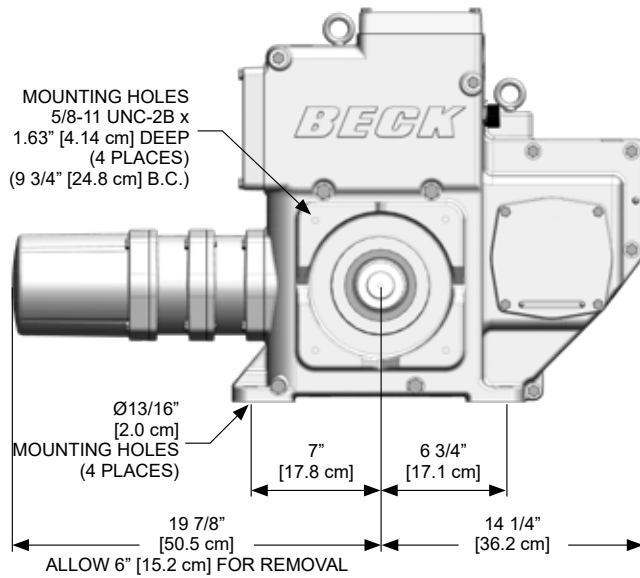

Model 11-489 Information

Approximate Weight	260 lbs. (118 kg)
--------------------	-------------------

TYPICAL VALVE MOUNTING

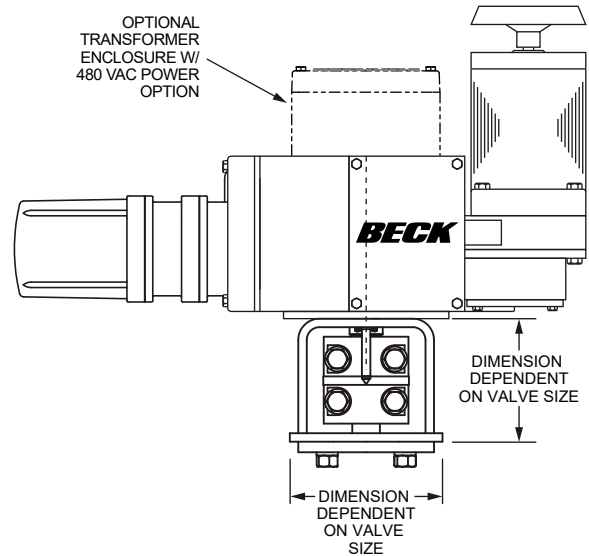

Recommended Screw Torques

	Screw Size (in.)	Wrench Size (in.)	Torque	
			lb-ft	N·m
Coupling Screw	-	-	*	*
Mounting Bracket Screw	5/8-11	15-16	100	135
Body Screw	1/2-13	3/4	50	68
Body Screw	3/8-16	9/16	20	27
Cover Screw	5/16-18	1/2	10	14
Motor Screw	3/8-16	9/16	16	22
Gear Module Screw	5/16-18	1/2	10	14

*Varies per application. Refer to the valve mounting specification sheet shipped with your actuator.

PRECAUTIONARY INFORMATION

SAFETY PRECAUTIONS



WARNING

Installation and service instructions are for use by qualified personnel only. To avoid injury and electric shock, do not perform any servicing other than that contained in this manual. Please read and understand the appropriate sections in this manual before attempting to install or operate your actuator.

STORAGE INFORMATION

Beck actuators should be stored in a clean, dry area where the temperature is between -40° and 85°C (-40° to 185°F).

Damage due to moisture while in storage is not covered by warranty.

INSTALLATION—MECHANICAL

See the instructions beginning on page 9 for details regarding mechanical installation. Refer to the outline dimension drawings for physical dimensions and required clearances.

VALVE ACTUATOR INSTALLATIONS



CAUTION

Working with valves installed in a pipeline can be dangerous. Take appropriate precautions when mounting to installed valves.

INSTALLATION—ELECTRICAL

See the instructions beginning on page 10 for details regarding electrical installation.



CAUTION

For maximum safety, the Beck actuator body should be grounded. Use the green grounding screw in the wiring compartment of the actuator.



CAUTION

Always close covers immediately after installation or service to prevent moisture or other foreign matter from entering the actuator.

CONDUIT ENTRIES

Conduit entries are provided for power and signal wiring. Temporary plugs are installed in the conduit entrances at the factory for shipping only and are not intended for permanent use. Prior to actuator operation, all conduit entrances must be properly sealed in accordance with National Standards or Regulatory Authorities.

COMPONENT LOCATION

MODES OF OPERATION

There are two basic modes of operation:

- **Handwheel**—local mechanical control
- **Handswitch**—local electrical control

Either of these modes can be used to test basic operation of your actuator during start-up.

HANDWHEEL

The Handwheel permits manual operation of the actuator without power. The Handwheel is coupled directly to the motor shaft at the rear of the motor housing and it rotates when the motor runs.

If power is available, the Handswitch must be moved to the STOP position before manually operating the Handwheel.



HANDSWITCH

A Handswitch allows local electric control at the actuator. In either of the STOP positions, the motor is blocked from running. In the CW or CCW positions, the motor runs to move the output shaft in the corresponding direction. When moving the output shaft using the Handswitch, the motor will stop when the limit switches are reached.

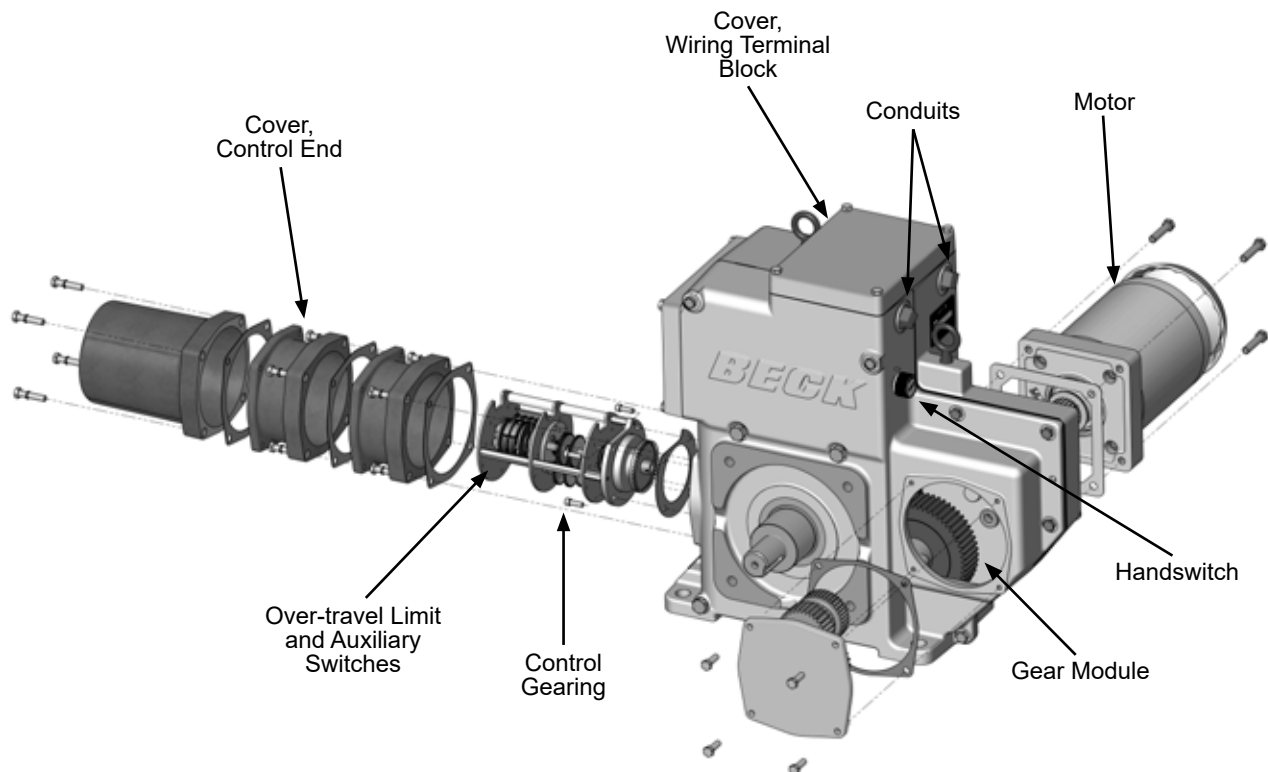

COMPONENTS

INSTALLATION Mechanical

INSTALLATION—MECHANICAL

The 11-483 actuator may be installed in any convenient orientation, because the gearing does not require an oil bath. Refer to the outline dimension drawings for physical dimensions and required clearances.

VALVE INSTALLATIONS



CAUTION

Working with valves and gates can be dangerous. Take appropriate precautions when mounting to installed valves or gates. Follow manufacturer precautions.

Whenever an actuator is being mounted on a valve, refer to the valve manufacturer's maintenance manual for specific valve-related instructions. *Consult the Beck Valve Mounting Specification sheet shipped with the actuator for specific instructions on assembly of the Beck actuator and mounting hardware to the gearbox or valve.* It is good practice to remove the valve from service if possible.

INSTALLATION Electrical

POWER QUALITY

Power quality disturbances such as power outages, transient voltages, harmonic distortions, and electrical noise will adversely affect your actuator performance. Protecting your actuator from these conditions can reduce downtime and promote longer life for the equipment. Following the industry accepted standards below will help protect your actuator.

- ✦ Select wiring materials according to the correct ampacity ratings dictated by national and local regulations.
- ✦ Shielded, twisted pair cables can be used for signal connections to avoid being affected by electrical noise. These signal wires, based on Noise Susceptibility Level (NSL) per IEEE-518, fall into the level 1 classification. A braided shield will be more effective than a wrapped foil shield. Signal wire shields should be connected to the actuator casting grounding screw. If grounding at the signal source is required, then the shield should not be grounded at the actuator.
- ✦ Raceways such as conduits and trays must be grounded at both ends to properly meet immunity requirements.
- ✦ An AC power ground connection should be made between the power source and the Beck actuator. Grounding connections including wire and metal conduit are permitted, but the actuator-grounding conductor may not be connected to a structured metal frame of a building.
- ✦ Surge suppression equipment that meets Underwriters Laboratory (UL) Standard 1449 may be used to protect against transient voltage conditions.
- ✦ Power Conditioners may be used to regulate the supply voltage and maintain a constant voltage level. They are helpful in protection against voltage sags and swells, as well as some measure of electrical noise protection.
- ✦ Harmonic filters may be used to minimize the effects of supply voltage waveform distortions and are used in applications that incur a large amount of high-frequency electronic noise.



CAUTION

Always close covers immediately after installation or service to prevent moisture or other foreign matter from entering the actuator.

ELECTRICAL INSTALLATION

Two 1" N.P.T. conduit connections are provided for power and signal wiring to the actuator. Conduits should be routed from below the actuator so that condensation and other contaminants flow away from the conduit. All conduit entrances must be properly sealed in accordance with National Standards or Regulatory Authorities.

Power and signal wires should be routed to the actuator separately and be either shielded cables or installed in conductive conduit and/or cable trays.

Refer to the wiring diagram furnished with your Beck actuator for proper AC power and signal connections. The customer must supply 120 Vac to power the actuator (standard configuration). The 120 Vac line connects to terminal C and neutral to terminal B. Other available power options include 208, 240 & 480 Vac.

It is advisable to provide normal short circuit protection on the AC power line. A copy of the wiring diagram is shipped with each actuator and is fastened to the inside of the terminal block cover. If there is no wiring diagram available, you may obtain a copy from Beck by providing the serial number of your actuator.

For maximum safety, the Beck actuator body should be grounded. Use the green grounding screw in the wiring compartment of the actuator.

TERMINAL SCREW TORQUES

Each terminal screw should be torqued to the proper specification upon landing the wire.

Terminals	Torque	
	(lb-in)	(N·m)
A-V	16	1.8
FF-SS*	9	1.0
1-3*	20	2.3

* Terminals included only with certain optional features.

INSTALLATION Wiring

The terminal block is located in a separate, gasketed compartment at the top of the actuator. Line voltage connections are made on terminal designations A through V. Low voltage signaling terminals designated AA through EE are not used in the 11-483.

Actuators equipped with optional transformers to accommodate popular voltages include an additional terminal strip and fuse for power wiring (with the exception of the 240 volt option). See optional transformer wiring connections (next page).

Terminal screws will accept standard spade or ring terminals, as well as bare wire. Terminals A through V are size #8. Optional transformer terminal screws (designated 1, 2, & 3) are size #10. All terminals will accept up to #12 AWG (3.31 mm²) except for optional transformer terminals (1-3) which will accept up to #10 AWG (5.26 mm²).

Typical wiring connections are shown below. Each actuator can be ordered with up to four optional auxiliary switches (wiring connections are described in the Configuration/Calibration section).



To prevent Handswitch initiated motion, remove jumper (JA) from between terminals A and C.



CAUTION
AC power to the actuator must be turned off before removing the jumper (JA).

Three additional terminals and fuse (F1) are provided with 3-phase power options.



FUSE (F1) 1 2 3

TYPICAL WIRING CONNECTIONS

(Each actuator has a specific wiring diagram on the inside of the terminal compartment cover)

11-483

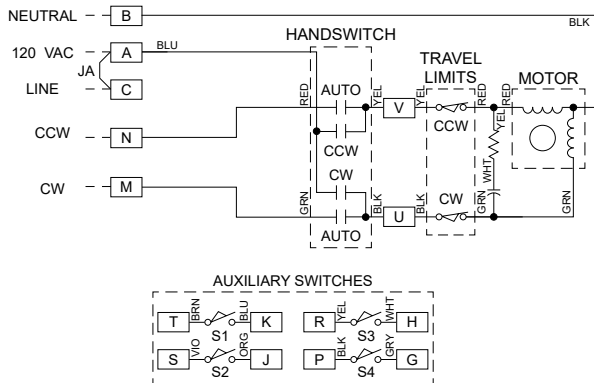

11-484

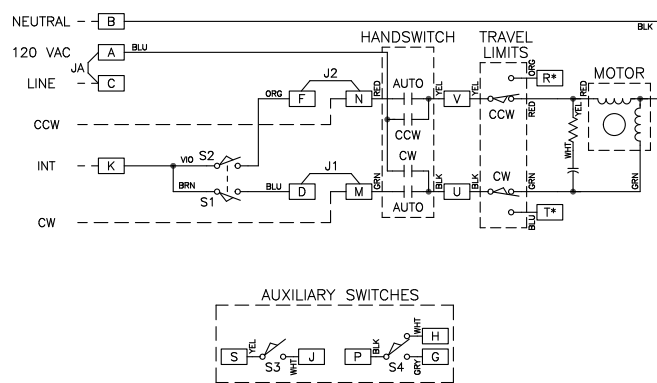

INSTALLATION Wiring

START-UP

POWER CONNECTIONS FOR ALTERNATE POWER OPTIONS

Optional Transformer for 480 Volts

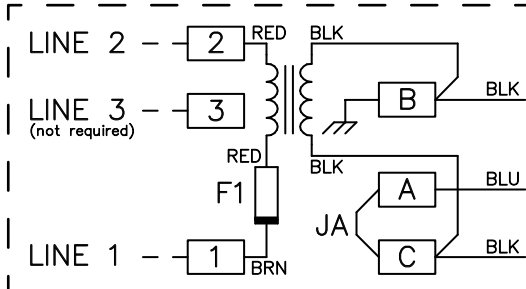

Optional Transformer for 208 Volts

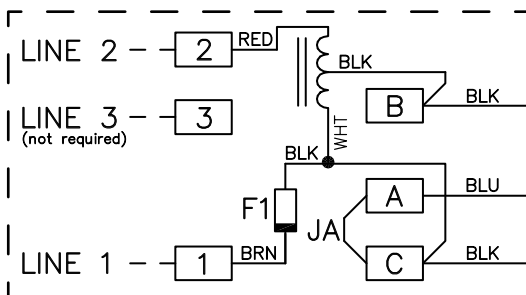

Optional Transformer for 240 Volts

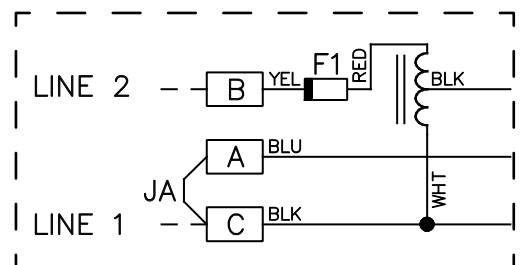

NOTE: All Beck actuators are shipped from the factory ready for installation. Each actuator is set-up and calibrated to the customer's specifications that were written into the equipment order. Electrical adjustments are generally not required before placing the actuator in operation.

START-UP INSTRUCTIONS

After the actuator is mounted and its wiring connections are made, it is ready to be tested for proper operation.

Turn on the power supply. Operate the actuator with the Handswitch and run it through its full stroke, both directions. Observe that the driven device travels through its desired stroke. If satisfactory, set Handswitch to the "AUTO" position.

If the actuator is to be operated with automatic control, turn on the controller and operate the actuator with the direct AC inputs from the controller. Check that the damper or valve strokes in the proper direction. If not, reverse the wiring connections and re-check.

If the actuator is to be push-button actuated, operate the actuator using the Handswitch and observe that direction of travel is correct. When travel of the driven device is satisfactory with reference to the push-buttons, the unit is ready for operation.

OPERATION

HOUSING

Beck electric actuators have individual cast aluminum compartments for each of the five main components: The control motor, wiring terminal block, drive train, electronic compartment, and control end. Gasketed covers and sealed shafts make the actuators ideally suited to outdoor and high humidity environments.

CONTROL MOTOR

The Beck control motor is a synchronous inductor motor which operates at a constant speed of 120 RPM in synchronism with the line frequency.

Motors are able to reach full speed within 25 milliseconds and stop within 20 milliseconds; although actual starting and stopping times will vary with load.

Beck motors have double grease-sealed bearings and require no maintenance for the life of the motor.

GEAR TRAIN

The gear train is a four-stage reduction, spur gear drive constructed with only heat-treated alloy steel and ductile iron gears for durability and long life.

Mechanical transmission of output shaft position to the control end is provided by a right angle gear set driven directly by the output shaft.

SELF-LOCKING MECHANISM (SLM)

An integral part of every control motor is the self-locking mechanism. This mechanical device couples the motor to the gear train and transmits full motor torque when rotated in either direction. When the motor is de-energized, the SLM instantaneously locks and holds the output shaft in position.

HANDWHEEL

Every Beck actuator is furnished with a Handwheel to permit manual operation of the valve without electrical power. Its solid construction design includes no spokes or projections, and turns at a safe, slow speed. The Handwheel is located at the rear of the control motor housing. The Handwheel is coupled directly to the motor shaft and rotates when the motor runs. Manual operation of the Handwheel (with electric Handswitch in "STOP" position) turns the output shaft without incorporating a clutch.

HANDSWITCH

A local electric Handswitch is provided on Beck actuators to permit operation at the valve or damper, independent of the controller. As a safety feature, the Handswitch is designed so that the controller can operate the actuator only when it is in the "AUTO" position. The sequence of the Handswitch is: "AUTO", "STOP", "CW", "STOP", "CCW".

In the "AUTO" position, two contacts are closed and the external controller contact completes the control circuit.

In the "CW" or "CCW" positions, contacts are closed to operate the actuator independently of the controller.

In the "STOP" position, all contacts remain open.

SWITCHES

Two end-of-travel limit switches and four auxiliary switches are provided with the 11-483. Switch cams are clamped onto the control shaft which rotates in relation to the output shaft. Cam position is field-adjustable. Switches are rated 6 A, 120 Vac. All auxiliary switch connections are made on the terminal block.

CONTROL

2-position control can be accomplished using manual push-buttons or discrete outputs from a control system. Preset end-of-travel limit switches provide the open / close operation travel limits. These travel limits are adjustable over the full range of travel and provide precise positioning repeatability.

DIRECTION OF OUTPUT SHAFT ROTATION

The direction of output shaft rotation is determined by observing the end of the actuator output shaft (see below).

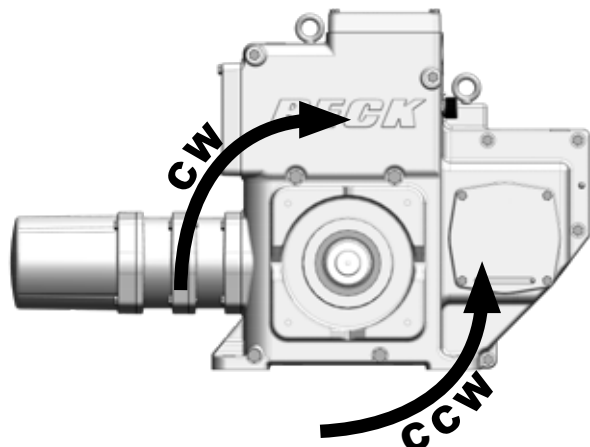

CALIBRATION Switches

NOTE: Your Beck actuator was shipped from the factory ready for installation; no electrical adjustments are required before placing it in operation. Each actuator is set up and calibrated to the specifications that were written into the equipment order.

Under normal operating conditions there is no need to recalibrate the actuator. However, if the application requirements change—or are different than specified on the equipment order—the actuator should be recalibrated according to the following procedures.

SWITCH ADJUSTMENTS

End-of-travel limit switches are factory set at each end of travel unless otherwise specified at time of order. Limit switches can be reset to limit travel of the output shaft to any number of turns within the acceptable travel range of the actuator (see page 5). Auxiliary switches are set as shown in the illustration on page 15 unless otherwise specified at time of order.

NOTE: The limit switches are the switches closest to the actuator body. To adjust these switches, it is necessary to remove the control end cover.

Switches are operated by cams which are clamped onto the control shaft (under the cylindrical cover). Setting a switch involves loosening the cam, moving the actuator output shaft to the desired position (number of turns), and positioning the switch cam so that it just operates the switch at that point. The use of a continuity meter is recommended to determine when the switch opens or closes. If such a meter is not available, it is possible to hear the switch click as the contacts open and close.



CAUTION

Do not attach the meter or attempt to move the switch cams until the actuator is disconnected from the line voltage and auxiliary switches are disconnected from external power sources.

SETTING LIMIT SWITCHES CW AND CCW

This procedure should be used if the factory limit switch settings must be changed in the field. It is advisable to operate the actuator fully in each direction, using the electric Handswitch to check switch settings before attempting to change them. Follow these instructions if they require adjustment:

1. Remove the cylindrical control end cover (and extensions) and the terminal block cover using a 1/2" wrench.
2. Use the electric Handswitch to drive the control shaft so that the CW switch cam screw is accessible. Using a 7/64" hex wrench, loosen the screw so that the cam is just snug on the shaft (see illustration, page 15).
3. Using the Handswitch, move the output shaft to the desired CW limit.
4. Turn the Handswitch to the "STOP" position.
5. **Disconnect power from the actuator.**
6. Connect a continuity meter across terminals B and U. Rotate the cam until the meter shows no continuity (switch contacts open).
7. Tighten the cam locking screw to 5 lb-in (0.56 N•m) torque.
8. Disconnect meter and ensure the Handswitch is in the "STOP" position.
9. Reconnect actuator power.
10. Rotate the actuator's output shaft in the CCW direction away from the CW travel limit. Note the direction of rotation on the lobe of the cam. The correct cam lobe motion is away from the switch lever with the switch lever on the lower part of the cam. If not correct, return to step 2 and reset the cam to the proper orientation.
11. Rotate the output shaft again to the desired CW travel limit. If the stopping point is reached, the switch is properly set.
12. Repeat instructions 2–11 for setting the CCW limit switch (CCW rather than CW). Connect the continuity meter across terminals B and V.
13. Replace covers and tighten cover bolts to 10 lb-ft (14 N•m) torque.

MAINTENANCE Routine

LUBRICATION / GEARING

Periodic lubrication is not required on Beck actuators.

During major maintenance outages, it is recommended that older actuators be inspected to ensure that the gearing is not worn or damaged.



CAUTION

Before removing the gear module assembly from the actuator body, secure the output shaft to prevent movement.

To inspect the gears, remove the gear module assembly. Clean the gears, removing as much old lubrication as possible.

Examine the gear teeth, shaft bore, and gear shafts for signs of excessive wear, scoring, or other damage. If there is no evidence of damage to the gearing, recoat the teeth and shaft bores of all gears with a heavy layer of Fiske Lubriplate GR-132 or equivalent (GR-132 is an extreme pressure grease with polymer additives). The ball bearing on the output shaft and crown gear shaft have double grease seals and require no maintenance for the life of the bearings. Inspect all other grease seals and replace any that show wear. Reassemble the actuator, referencing the outline dimension drawings on page 6 for appropriate bolt torques.

If it should ever be necessary to replace the output shaft assembly, 3rd combination gear, or output shaft bearings, a major overhaul is required and the actuator must be returned to the factory for a repair evaluation.



11-483 Gear Module Assembly

MAINTENANCE Component Replacement

This section covers replacement of many components of the actuator. Note that some components are not field-repairable. Refer to the outline dimension drawing on page 6 for location of components on the actuator.

If it should ever be necessary to replace the output gear, shaft, or output shaft bearings, a major overhaul is required and the actuator should be returned to the factory. During a major overhaul, the factory repair department will update the actuator to include all possible engineering improvements. See "HOW TO OBTAIN SERVICE" at the end of this manual.

Gaskets

During routine service, inspect removed cover gaskets for wear or damage. In order to protect internal components, worn or damaged gaskets and O-rings should be replaced.

To remove, scrape all of the old adhesive and gasket material from the body housing and covers, if necessary. Replacement gaskets are self-adhering, silicone rubber. Peel the backing off the replacement gasket and carefully apply to the actuator body.

Seals

Worn or damaged output shaft, control end shaft, and motor shaft seals should be replaced to prevent damage to internal bearings and drive train parts.

To remove the shaft seal, push the blade of a small screwdriver along the shaft and under the seal lip. **CAUTION:** The seal is approximately 1/4" (6.35 mm) wide. Do not force the screwdriver blade beyond the width of the seal; damage to the shaft bearing could result. Pry up on the seal and force it out of the housing. Clean the shaft and housing then press in the replacement seal with the closed side facing outward.

Bearings

The Beck electric actuator contains ball bearings on the output shaft, control end shaft, and motor shaft. Bushings and thrust washers are used on combination gears. Field replacement of these components is not recommended.

Motor shaft bushings in the body of the 11-483 can be replaced. **TIP:** To remove, fill the bushing with a heavy grease. Select a drive pin that slip fits into the bushing. Insert the pin into the bushing and tap with a mallet. This will force the bushing out of the body casting.

Motor

The control motor is not field-repairable. Disassembly of the motor will result in a loss of torque that can only be restored by returning the motor to the factory for re-magnetization.

To remove the motor, first disconnect the motor wires in the terminal compartment of the actuator. Remove the terminal block and plate as an assembly. Remove the black wire from the terminal post, cut the red motor wire near the red-yellow-red butt joint and disconnect the green wire from the motor capacitor. Remove the mounting bolts and motor. Carefully slide the motor out of the actuator body.

To install the motor, insert the three-wire sleeve through the wire hole in the motor mount and into the terminal compartment. Carefully slide the motor into the actuator body. Rotate the motor shaft, if necessary, to engage the pinion with the first combination gear. Install motor mounting bolts and torque to recommended values. Reconnect the motor wires. See the following section prior to reinstalling the terminal plate.

Motor Resistor and Capacitor

The motor resistor and capacitor are located under the terminals in the terminal compartment. To replace a resistor or capacitor, remove the terminal cover. Remove the terminal plate. Remove the existing part and transfer the wires one at a time to the replacement part. Inspect the terminal plate gasket and replace if necessary. To ensure a watertight seal between the plate and gasket, coat the gasket with a thin film of grease before replacing the terminal plate. Torque the screws to 3 lb-ft (4 N•m).

MAINTENANCE Component Replacement

SELF LOCKING MECHANISM (SLM)

The Self Locking Mechanism (SLM) is assembled to the front of the motor and couples the motor to the gear train. The primary function of the SLM is to lock the gear train in place when the motor is de-energized. When the motor is energized, the SLM releases and allows the motor to drive the gearing.

There is no recommended maintenance interval for the SLM. The SLM can last for many years in normal service. SLM wear is a function of loading and the number of starts/stops the motor experiences over time. Overloading or stalling the actuator will accelerate SLM wear.

Signs of wear include the inability of the actuator to hold position when the motor is de-energized. This could result in persistent on-off oscillation. Severe SLM wear or damage may result in a loss of torque at the output shaft.

It is often possible to confirm SLM wear or damage by checking motor operation with the Handwheel. Place the Handswitch in the STOP position, and rotate the motor Handwheel back and forth. There should be free play before the motor pinion/gearing turns (up to one tenth of a full Handwheel rotation). Lack of free play or rough motor movement may indicate the need for SLM reconditioning.

Disassembly and close inspection of the SLM components is required to fully evaluate its condition.



WARNING

Electrical shock hazard. Disconnect power before proceeding.

Support the load before removing the motor/SLM from the actuator.

SLM REBUILD KIT MAJOR COMPONENTS (Descriptions & Part Numbers)

Motor Assembly	20-2201-34
Rebuild Kit (GL181-134)	12-8067-13
Spring	14-9980-26
Friction Material (GL181-134)	14-9409-52
Spring Pin	10-7111-05
Thrust Washer/Bearing	14-9400-02
Pinion	14-9940-69
Steel Ball	14-9420-03 (8)
Locking Disc	14-9330-19
Motor Gasket	20-0660-08
Instruction Sheet	80-0016-02
Terminal Joint	20-0032-01 (3)
Slip-on Terminal	20-0030-01
Spacer	20-2090-03
O-ring	14-9840-16
Motor Screw	30-0306-40 (4)

DISASSEMBLY AND CLEANING

When wear or damage is suspected, disassembly and cleaning may be required to determine the extent of needed repairs. Individual parts may be replaced, with the exception of the actuator collar, which is not field replaceable. Refer to the illustration at right.

For SLM disassembly and inspection:

1. Disconnect power from the actuator.
2. Secure the actuator load, and remove the motor assembly (see page 17). Handle the motor with care so as not to damage the rotor shaft.
3. Pushing down firmly on the pinion, measure the gap between the stop collar and the thrust washer. This distance should measure $0.025 \pm .005$ ". An excessive gap indicates worn SLM components.
4. Use a felt tip pen to mark the location of the castle nut on the shaft. Support the end of the rotor shaft to prevent it from bending, and drive the 1/8" spring pin out. Carefully (the spring assembly is spring-loaded), remove the castle nut, thrust washer/bearing, spacer, pinion, spring, and steel balls. Remove the (4) 1/4-20 screws and the front motor end. DO NOT remove the front motor shield or the rotor from the stator on any model.

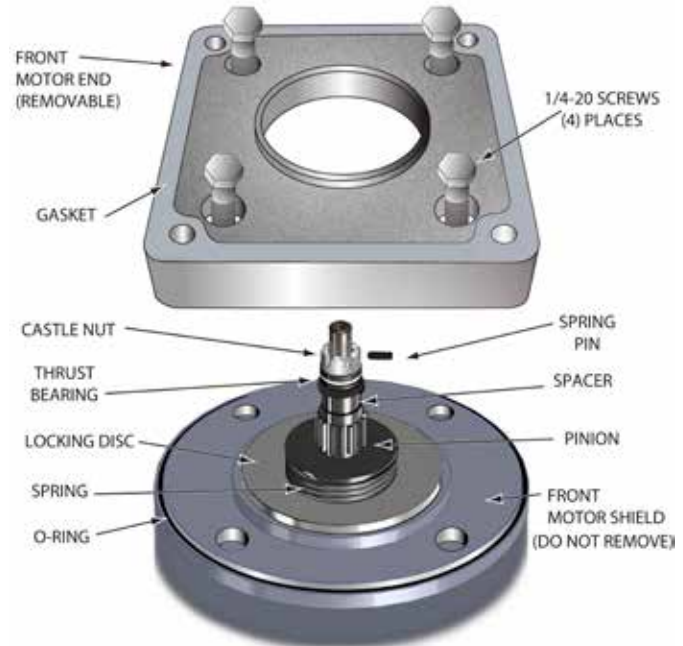

11-483 SLM COMPONENTS



CAUTION

Do not disassemble the motor any further, as it has no other user serviceable parts. Further disassembly will result in demagnetization of the motor and loss of the required torque.

5. Clean grease from the pinion and locking disc for inspection. A small amount of dust residue from the friction material is normal. Clean the actuator collar detents with a rag and inspect for wear. Inspect the friction material for excessive wear or damage. If the friction material does not appear to be damaged, clean with alcohol to remove any contaminants.
6. Identify worn parts and replace as needed. Note that wear on the pinion teeth may indicate wear on the meshing gear. Further inspection of the gear module assembly is recommended. Drive collar detent wear will require factory repair of the motor.

MAINTENANCE Component Replacement

REPLACEMENT AND REBUILD INSTRUCTIONS

1. If the friction material requires replacement, scrape off the old friction material and thoroughly clean the bonding surface to ensure flatness for the new friction material. Glue the new friction material in place with Loctite 454 Instant Adhesive or equivalent, taking care to keep the material flat and clean.
2. Apply a film of grease (Fiske Lubriplate GR-132 or equivalent) to the surface of the ball detents (16 places). Apply a *thin* film of grease to the inner diameter of the locking disc bore. Do not let the grease contact any friction surfaces. Excess grease can contaminate the friction surface and reduce SLM effectiveness.
3. With the motor shaft pointed up, place a steel ball into each of the actuator collar detents. Install the locking disc and place a steel ball into each of the detents on the top of the locking disc.
4. Install the spring on top of the locking disc. Compress the spring by pushing down with the pinion. While holding the pinion in place, install the spacer, thrust bearing, and castle nut. Note: The grooved washers on each end of the thrust bearing have differently sized holes; the end with the washer having the smallest hole should be installed next to the castle nut. Thread the castle nut onto the shaft to hold the spring in compression.
5. Replace the front motor end O-ring (see figure at left) and install the front motor end with the (4) 1/4-20 screws in a crisscross pattern, torquing to 6 lb-ft (8 N•m). Place RTV around the wire entry into the motor.
6. Pushing down firmly on the pinion, measure the gap between the castle nut and the thrust bearing. This distance should measure $0.025 \pm .005$ ". This space is necessary to ensure proper operation. Tighten or loosen the castle nut as necessary to achieve the proper gap and simultaneously align one of the slots with the hole in the motor shaft. One complete slot rotation will change the gap by 0.009". Install the new 1/8" spring pin while supporting the shaft.
7. Recoat the gear teeth and components above the pinion liberally with a layer of Fiske Lubriplate GR-132 or equivalent.

OVER-TRAVEL LIMIT AND AUXILIARY SWITCHES

Complete switch assemblies may be replaced. It is not possible to replace individual switches. To replace switch assemblies, follow the instructions below.



WARNING

Electrical shock hazard. Disconnect power before proceeding.

Remove the control end cover by loosening the four captive, socket head cap screws (1/2" wrench). Remove the screws holding the switch assembly to the switch plate and slide it out to the side.

Transfer the wires to the terminals of the replacement assembly, ensuring the correct wire is transferred to the correct replacement assembly terminal (wires have push-on lugs). Install the replacement assembly and note that it rotates around one screw to permit an adjustment of the cam-to-switch lever spacing and switch operating point. To set the switch, place a .030" (.75 mm) shim between the cam and switch lever (see photo at right). The switch lever should be on the low or minimum radius portion of the cam when setting the switches. Position the switch assembly so that the switch is just actuated. DO NOT overstress the switch lever. Tighten both screws to 10 lb-in (1 N•m) torque and remove the shim.

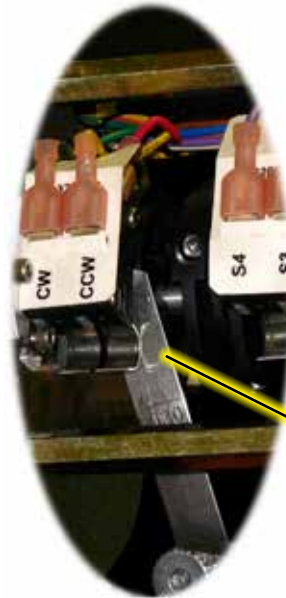

.030" (.75 mm) SHIM SHOULD BE INSERTED BETWEEN SWITCH ACTIVATION LEVERS AND THE CAMS WHEN SETTING SWITCHES.

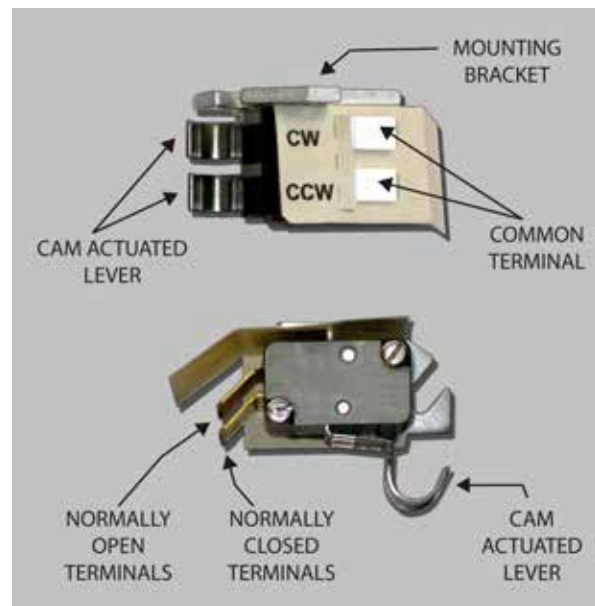

SWITCH PARTS

Description	Part Number
Over-travel limit switch assembly (CW/CCW)	20-3202-10
Auxiliary limit switch assembly, (4) switches (S1/S2/S3/S4)	20-3202-12
Limit switch cam assembly	11-0931-02

MAINTENANCE Component Replacement

FUSE (F1) REPLACEMENT (FOR ACTUATORS EQUIPPED WITH OPTIONAL 208V OR HIGHER POWER SUPPLY)

If it is necessary to replace the power fuse (F1), use the following procedure:



WARNING

Electrical shock hazard. Disconnect power before proceeding.

Remove the terminal block cover. Locate the fuse holder (similar to the illustration below).

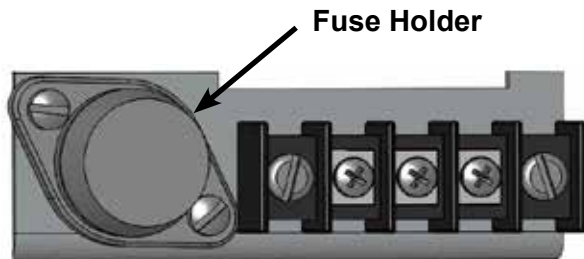

Turn the fuse holder CCW while pressing down. The fuse holder should spring loose when free. Remove the fuse holder from the actuator. Pull the fuse free from the holder. Replace the fuse with the same type (see table below) by pushing it into place.

Reinsert the fuse holder into the actuator. Turn the fuse holder CW while pressing down to tighten. Replace the terminal block cover. Tighten the cover screws to 6 lb-ft (8 N•m) torque.

REPLACEMENT FUSES (F1)

Input Voltage	Amps	Volts	Type	Part No.
208	3.2	250	Time Delay	11-1370-25
240	3.2	250	Time Delay	11-1370-25
480	1.4	600	Time Delay	11-1372-30

HANDSWITCH



WARNING

Electrical shock hazard. Disconnect power before proceeding.

REMOVE THE EXISTING HANDSWITCH:

1. Remove power from the actuator.
2. Remove the terminal cover (1/2" wrench).
3. To access the Handswitch, the terminal barrier plate must be removed.
4. Clip the five wires from the old Handswitch (removing any tie wraps or sleeving that may interfere).
5. Remove the Handswitch knob by loosening the two inset screws (5/64" hex wrench).
6. Remove the threaded bushing behind the Handswitch knob. The remaining Handswitch assembly components may now be removed from the terminal compartment.

INSTALL THE NEW HANDSWITCH:

7. Insert the new threaded bushing through the actuator onto the shaft, then attach the components leading to the switch as shown in the illustration below.
8. Place the seal in the bushing, then insert the knob over the bushing. Tighten the two inset screws to 3 lb-ft (4 N•m).

9. Splice the wires from the new Handswitch assembly to the wires from the actuator, color to color. Ensure the wiring is not exposed after splicing.
10. Replace the terminal cover, tightening the captive screws to 10 lb-ft (14 N•m).

NOTE: When the Handswitch is turned fully clockwise, "AUTO" should be indicated. Be sure to place the tab on the tabbed washer into the slot in the actuator body to secure the Handswitch in place.

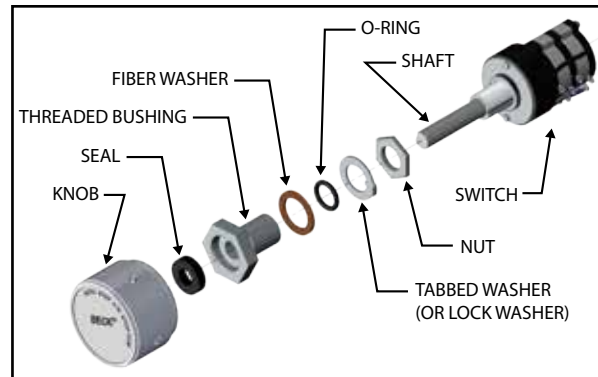

HANDSWITCH COMPONENTS

MAINTENANCE Spare Parts & Part Numbers

RECOMMENDED SPARE PARTS

The table below lists common recommended spare parts for the 11-483 actuator.

The Beck website (www.haroldbeck.com) provides an actuator serial number lookup tool which will provide details specific to your actuator.

COMMON RECOMMENDED SPARE PARTS

Description	Part Number
Fuse (F1) w/ operating voltage >120 V	See page 22
Limit switch assy. (CW / CCW)	20-3202-10
Auxiliary switch assy. (4 switches, S1-S4)	20-3202-12
Gasket Kit	20-3110-03
Motor, Capacitors, Resistor Assy.	See below

MOTOR, CAPACITORS, & RESISTORS

Motor ¹					Capacitor		Resistor Assy.	
Part Number*	Current (Amps at 120 Vac, 60 Hz ²)	Torque (N•m)	RPM	Freq. (Hz)	Part Number	Value (µf)	Part Number	Value (Ω)
20-2201-34	3.0	14.0	120	60	14-2840-15 14-2840-09	25 6	20-1971-06	18
				50	14-2840-15 14-2840-05 14-2840-09	25 8 6		

¹The motor is rated 120 Vac regardless of operating voltages using optional transformers.

²50 Hz currents do not exceed 120% of 60 Hz levels.

*Note that motor replacement part numbers will include the suffix "KIT"; e.g., 20-2201-34-KIT.

OR

Resistor & Capacitor Assy.			
Freq. (Hz)	Part Number	Value (µf)	Value (Ω)
60	20-0322-06	31	18
50	20-0322-07	39	24

TORQUE & SPEED BY GEAR MODULE ASSEMBLY and TRAVEL RANGE WITH MAX. STROKE TIMES

FULL TRAVEL (turns)	~ MAXIMUM STROKE TIME (mins.)	
	Gear Module P/N 14-9732-41**	Gear Module P/N 14-9732-42**
	90 lb-ft (122 N•m) 9.1 rpm* @ 60 Hz	120 lb-ft (122 N•m) 6.7 rpm* @ 60 Hz
5 to 9	1.0	1.3
7 to 14	1.5	2.1
14 to 25	2.7	3.7
25 to 45	4.9	6.7
35 to 70	7.7	10.4
65 to 126	13.8	18.8
115 to 227	24.9	33.9
200 to 408	44.8	60.9

*50 Hz travel speed = 60 Hz x 1.2.

**Note that gear module replacement part numbers will include the suffix "KIT"; e.g., 14-9732-41-KIT.

TROUBLESHOOTING

If your unit contains a Stall Protection Module (SPM), refer to publication 80-0017-03, "Troubleshooting".

CONDITIONS	POSSIBLE CAUSES	CORRECTIONS
Actuator motor oscillates in AUTO mode.	Physical obstruction (e.g., valve jammed or load greatly exceeds actuator rating.	Check operation with Handswitch and remove obstruction if present.
	Excessive wear in gear train or bearings.	Replace worn drive train parts.
Actuator motor erratic or runs in wrong direction during auto or manual operation.	Control motor winding open.	Replace control motor.
	Control motor capacitor shorted or open.	Replace capacitor.
	Control motor resistor open.	Replace resistor.
Actuator will not run in either direction or one direction during auto or manual operation.	Limit switch failure.	Replace limit switch.
	Handswitch failure.	Replace Handswitch.
Actuator does not stop at normal or desired limit of shaft travel.	Limit switches adjusted incorrectly.	Readjust limit switches.
	Control signal interrupted.	Restore controller signal.
	Limit switch failure.	Replace limit switch.
Actuator drives to 100% and stays.	Handswitch left in CW/CCW position.	Return Handswitch to AUTO position.
	CW/CCW limit switch failure.	Replace limit switch.
Actuator does not stay in place with power off.	SLM friction surface worn.	Replace SLM.
Control motor runs, but output shaft does not move in one or both directions.	SLM failure.	Replace SLM.

APPENDIX *Optional LED Display*

The optional LED display board (p/n 22-5008-49) provides lighted color indication of the actuator output position. The board resides in the same location (the electronics compartment) as that of the optional DCM display board available with 4–20 mA modulating actuators (control option 9). The same compartment cover with a tempered glass window is used with all versions.

This display board includes a red, green and yellow LED to indicate the actuator output position. The lights are driven by 120 Vac actuator power and are energized using the actuator's internal auxiliary switches.

The red and green LEDs, which are intended to indicate OPEN and CLOSE ends-of-travel are easily set up by connecting jumpers on the actuator's terminal block (see the wiring diagram below).

The yellow LED will light whenever both the red or green LED are not lit (when the actuator is not at either end-of-travel limit). If desired, the yellow LED may be turned off with a slide switch located on the board.

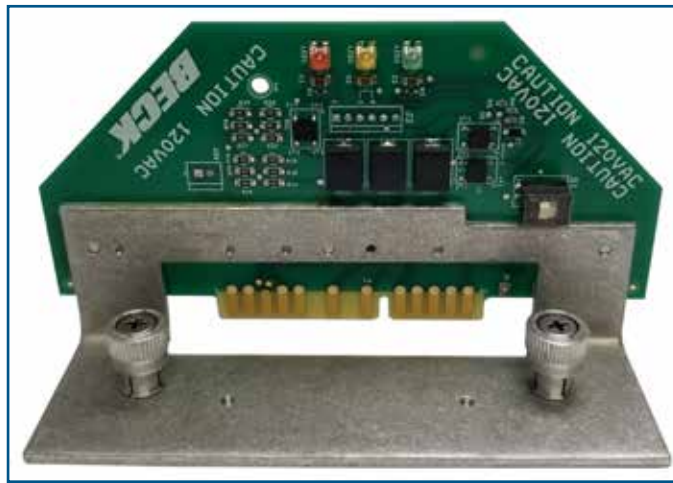

OPTIONAL LED DISPLAY BOARD

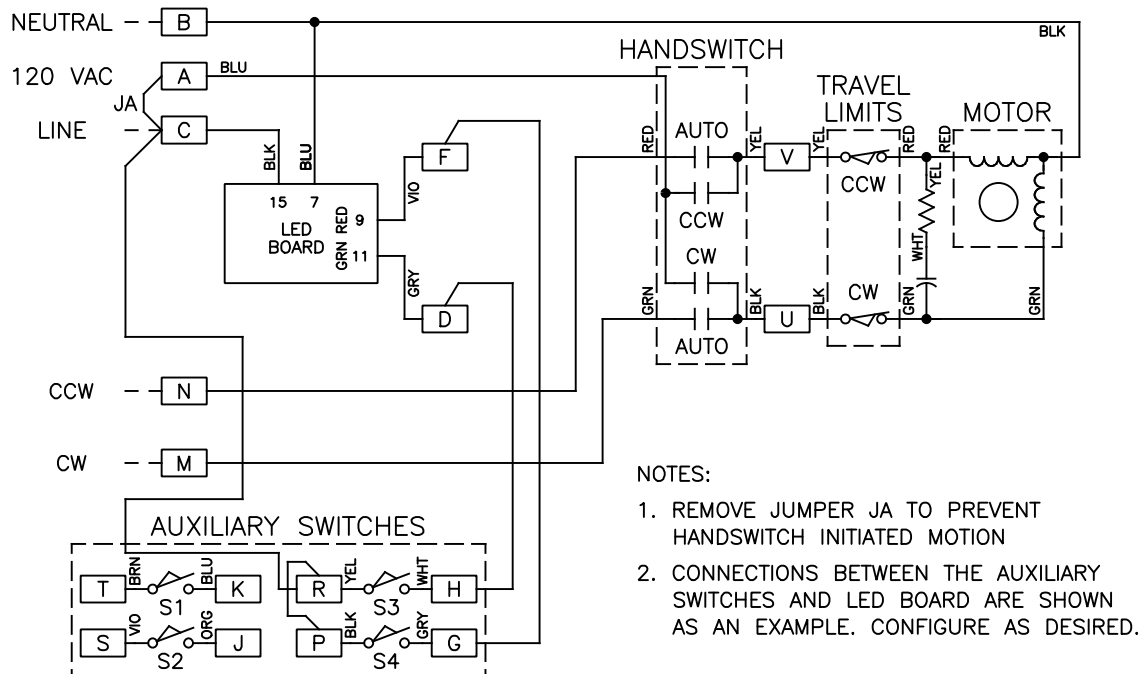

TYPICAL WIRING DIAGRAM

APPENDIX *Optional Locking Handswitch*

A locking Handswitch is available. When installed, the Handswitch may be locked into any position (as shown below).

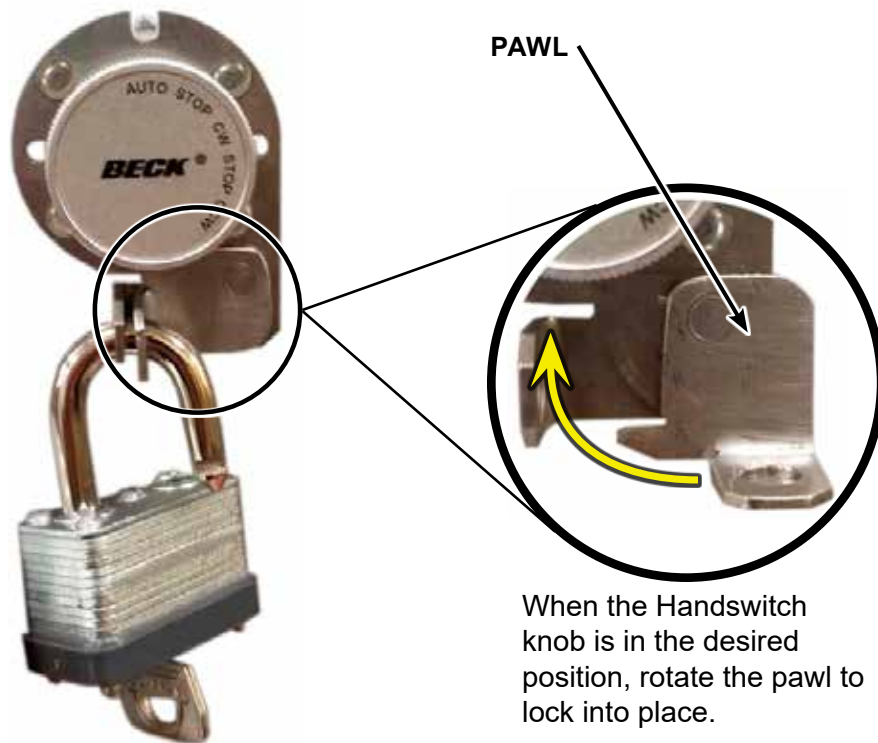

20-3320-75 (5-POSITION LOCK)

NOTES



INDEX

Appendices	26–27	Outline Dimension Drawings	6
Optional LED Display	26	Power Quality	10
Optional Locking Handswitch	27	Precautionary Information	7
Application Reviews	31	Product Demonstrations	31
Auxiliary Limit Switches	15, 21	Self-Locking Mechanism (SLM).....	13, 18–19
Setting Switches	15	Services	31
Replacing Switches	21	Site Surveys	31
Component Location	8	Spare Parts, Recommended	24
Component Replacement.....	17–23	Specification Writing	31
Calibration	14–15	Start-up.....	12
Limit Switches.....	14	Storage Information	7
Auxiliary Switches.....	15	Table of Contents.....	3
General Specifications.....	4–5	Torque, Speed, Travel Range, Timing	24
Handswitch	8, 23	Troubleshooting	25
Handwheel.....	8	Warranty Statement.....	31
How to Obtain Service.....	31		
Installation	9–12		
Electrical	10		
Mechanical	9		
Valves	9		
Wiring	11–12		
Introduction.....	2		
Limit Switches.....	14, 21		
Setting Switches	14		
Replacing Switches	21		
Maintenance	16–24		
Bearings	17		
Component Replacement.....	17–23		
Gaskets	17		
Handswitch	23		
Lubrication/Gearing	16		
Motor Assembly	17		
Motor Capacitor & Resistor Network	17, 24		
Limit & Auxiliary Switches	21		
Routine	16		
Seals.....	17		
SLM	18–19		
Spare Parts, Recommended	24		
Operation.....	13		

SERVICES

PRODUCT DEMONSTRATIONS

Each of Beck's Sales Engineers has access to actuator models for demonstration at virtually any of their features at your location. In order to arrange to see a Beck actuator in your plant or office, contact Beck's Sales Department.

SITE SURVEYS

Beck Sales Engineers are available to discuss your process control requirements. Often a visit to your location is the best way to gain a thorough understanding of your needs, in order to meet them most accurately and completely.

Mounting hardware, torque requirements, linkage, control signal information, and optional equipment can be analyzed most effectively at the work site. Beck's analysis at the job site can help ensure that specifications are accurate, especially in the case of complex applications.

APPLICATION REVIEWS

By sharing your needs with a Beck Sales Engineer you can take advantage of the best application advice for the type of control you need. This review will yield a better understanding of the

versatility of Beck actuators for your installations, as well as complete details on options and accessories to make the process as effective as possible.

SPECIFICATION WRITING

Beck provides specification writing assistance in order to help you specify and order the right actuators for your applications. Beck Sales Engineers will work with you to make it easier for you to obtain the proper equipment and give you confidence that no details are overlooked.

HOW TO OBTAIN SERVICE

Factory repair of actuators or subassemblies is available for both normal and emergency service. To assure prompt processing, contact the factory to receive a Returned Material Authorization (RMA) number. If a repair estimation is desired, please send the name and phone number of your contact for service authorization. It is helpful to include a description of the work desired with the shipment or, in the event of a problem, the malfunction being experienced.

THREE YEAR LIMITED WARRANTY STATEMENT*

Harold Beck & Sons, Inc. (Beck) warrants that our equipment shall conform to Beck's standard specifications. Beck warrants said equipment to be free from defects in materials and workmanship. This warranty applies to normal recommended use and service for three years from the date on which the equipment is shipped. Improper installation, misuse, improper maintenance, and normal wear and tear are not covered.

The Buyer must notify Beck of any warranty issues within 37 months of original shipment date and return the goods in question, at Buyer's expense, to Beck for evaluation. If the product fails to conform to the warranty, Beck's sole obligation and the Buyer's exclusive remedy will be: 1) the repair or replacement, without charge, at Beck's factory, of any defective equipment covered by this warranty, or 2) at Beck's option, a full refund of the purchase price. In no event will Beck's liability exceed the contract price for the goods claimed to be defective.

THIS WARRANTY IS EXPRESSLY IN LIEU OF ANY OTHER EXPRESS OR IMPLIED WARRANTY, INCLUDING IMPLIED WARRANTIES OF MERCHANTABILITY AND FITNESS FOR A PARTICULAR PURPOSE, AND ALL OTHER OBLIGATIONS OR LIABILITIES OF BECK. In no case shall Beck be liable for any special, incidental or consequential damages based upon breach of warranty, breach of contract, negligence, strict tort, or any other legal theory. Such damages include, but are not limited to, loss of profits, loss of revenue, loss of use of the equipment or any associated equipment, cost of capital, cost of any substitute equipment, facilities or service, downtime, the claims of third parties including customers and injury to property.

Buyer acknowledges its responsibilities under OSHA, related laws and regulations, and other safety laws, regulations, standards, practices or recommendations that are principally directed to the use of equipment in its operating environment. Buyer acknowledges that the conditions under which the equipment will be used, its use or combination with, or proximity to, other equipment, and other circumstances of the operation of such equipment are matters beyond Beck's control. **Buyer hereby agrees to indemnify Beck against all claims, damages, costs or liabilities (including but not limited to, attorney's fees and other legal expenses), whether on account of negligence or otherwise, except those claims based solely upon the negligence of Beck and those claims asserted by Beck's employees which arise out of or result from the operation or use of the equipment by Beck's employees.**

***Note: Internal water damage is not covered by warranty.**

A 100% EMPLOYEE OWNED COMPANY

BECK

~ founded 1936 ~

SINCE 2021



HAROLD BECK & SONS, INC.

11 TERRY DRIVE • NEWTOWN, PENNSYLVANIA 18940 • USA

PHONE: 215-968-4600 • FAX: 215-860-6383 • E-MAIL: sales@haroldbeck.com

www.haroldbeck.com

Made in USA

