

80-0042-00
Rev. 8.6

MODELS 42-107
42-105
42-103

BECK[®]

INSTRUCTION MANUAL



ELECTRIC ACTUATORS FOR INDUSTRIAL PROCESS CONTROL

TABLE OF CONTENTS

Product Description	2
General Specifications.....	3
Outline Dimensions	5
Installation	6
Power and Signal Wiring	6
Safety Precautions	9
Start-up Instructions	10
Calibration	11
Travel Limit Switch Adjustment.....	11
Setting Auxiliary Switches.....	13
Changing Direction of Travel	14
Feedback Signal.....	15
Demand Input Signal.....	17
Loss of Signal Function	18
Deadband Adjustment	19
Short-stroke Operation (Reducing Full Stroke Travel Distance).....	19
Maintenance	20
Component Replacement.....	20
Troubleshooting	21
Appendix	22
Services	23
Warranty	23

PRODUCT DESCRIPTION

INTRODUCTION

Beck's Group 42 actuators are designed to meet the actuation needs of long stroke linear applications. Typical applications include burner air registers and OFA port dampers, but they can be used on any application requiring up to 18 inches of linear stroke. Employing Beck's unique design characteristics, reliability and quality into a long stroke linear actuator design fills a much requested slot in the Beck family of products.

As with all Beck actuators, the Group 42 is designed for simple installation, no duty cycle limitations, excellent performance and little or no required maintenance.

Ideally suited for harsh industrial environments, the Group 42 handles long stroke applications requiring up to 1,000 lbs. (4 450 N) of thrust. The design employs a highly efficient ball screw coupled with a time-proven Beck motor and offers consistent, repeatable positioning as precise as 0.25% of span.

Like all Beck actuators, the Group 42 incorporates a heavy-duty, weather-proof, cast aluminum body.

HAZARDOUS LOCATION ACTUATORS FOR DUST AREA CLASSIFICATIONS (OPTIONAL)

Group 42 Actuators are available approved for the following Protection Methods and Protection Concepts, suitable for use in:

Class II, Division 1, Groups E, F and G; T3C

Class II, Division 2, Groups F & G; T3C

Class III, Division 1 & 2

Enclosure type 4X

Enclosure rated IP66

Tambient = -30°C. to 70°C. (120V operation)

-30°C. to 60°C. (240V operation)

PRODUCT DESCRIPTION

GENERAL SPECIFICATIONS

Actuator Power	120 V ac, single-phase, 50 or 60 Hz
Allowable Tolerance	+10% / -15%
Max. Current & Power	1.2A, 144W @ 120 V ac
Output Thrust and Timing	1,000 lbs (4 450 N), 4.2 sec/in (1.65 sec/mm)
Stroke Range	5 to 18 inches (127 to 457 mm)
Weight	Approx. 71 lbs (32.2 kg), depending on selected options.
Operating Conditions	-40° to 85° C. (-40° to 185° F.) 0 to 100% relative humidity, non-condensing
Control Options	Three types of control are available: 1) Open/close option 3. Two position control using manual pushbuttons or an automatic controller. 2) Direct ac control option 5. Actuator is energized by 120 V ac line current from a remote controller or manual switches. 3) Modulating analog control option 7. Onboard actuator control electronics position output proportionally to mA Demand input signal.
Demand Input Signal (Option 7)	4–20 mA or 1–5 V dc
Deadband	1.0% of Span
Minimum Step	.25% of Span
Hysteresis	.5% of Span at any point
Position Feedback Signal (Options 5 & 7)	4–20 mA or 1–5 V dc Feedback may be configured as a two wire transmitter or as a four wire active signal source. Two wire systems require a customer supplied external power supply. Four wire systems require 120 V ac supply to the actuator.
Isolation	Demand input and position Feedback signals are isolated from ground and the ac power line. Signal buffering provides 24 V dc isolation between the signals.
Action on Loss of Power	Stays in place.

Continued

PRODUCT DESCRIPTION

GENERAL SPECIFICATIONS, cont'd

Action on Loss of Demand Input Signal (Option 7)	Stays in place or moves to predetermined position with ac power supplied.
Stall Protection (Option 7)	If the motor tries to run in one direction for more than approx. 136 seconds, it will shut off.
Stall Relay Contacts (Option 7)	Form A, 10 volt-amperes at 120 V ac or dc
Action on Stall (Option 7)	Motor power is turned off when relay contacts open (after 136 seconds of stall). Remote signal is available.
Travel Limit Switches	Two Form C (Retract and Extend), field-adjustable. Rated 10 A, 125/150 Vac; .5 A, 125 Vdc; .25 A, 150 Vdc.
Auxiliary Switches	Two Form C rated for 1 A, 250 V ac., field-adjustable. Rated 10 A, 125/150 Vac; .5 A, 125 Vdc; .25 A, 150 Vdc.
Handswitch (Option 7)	Permits local electrical operation, independent of Demand input signal.
Handwheel	Provides manual operation without electrical power.
Customer Wiring	Terminals accommodate up to 12 AWG (3.31 mm ²).
Motor	120 V ac, single-phase, no burnout, non-coasting. Capable of 60 starts per minute.
Enclosure	Precision-machined aluminum alloy, painted with corrosion-resistant polyurethane paint, to provide a rugged, dust-tight, weatherproof enclosure. Type 4X; IP66.* Actuators designed for hazardous locations are also available.
Mounting Orientation	Can be mounted in any orientation.
Standards*	CSA Labeled (US & Canada); CE Compliant; UKCA Compliant

*NOTE: May not be available with all options and models. For more information, please call Beck at 215-968-4600.

OUTLINE DIMENSION DRAWINGS

MODEL 42-107, -105 & -103 SPECIFICATIONS
 (All dimensions are in inches and [mm] and are subject to change)

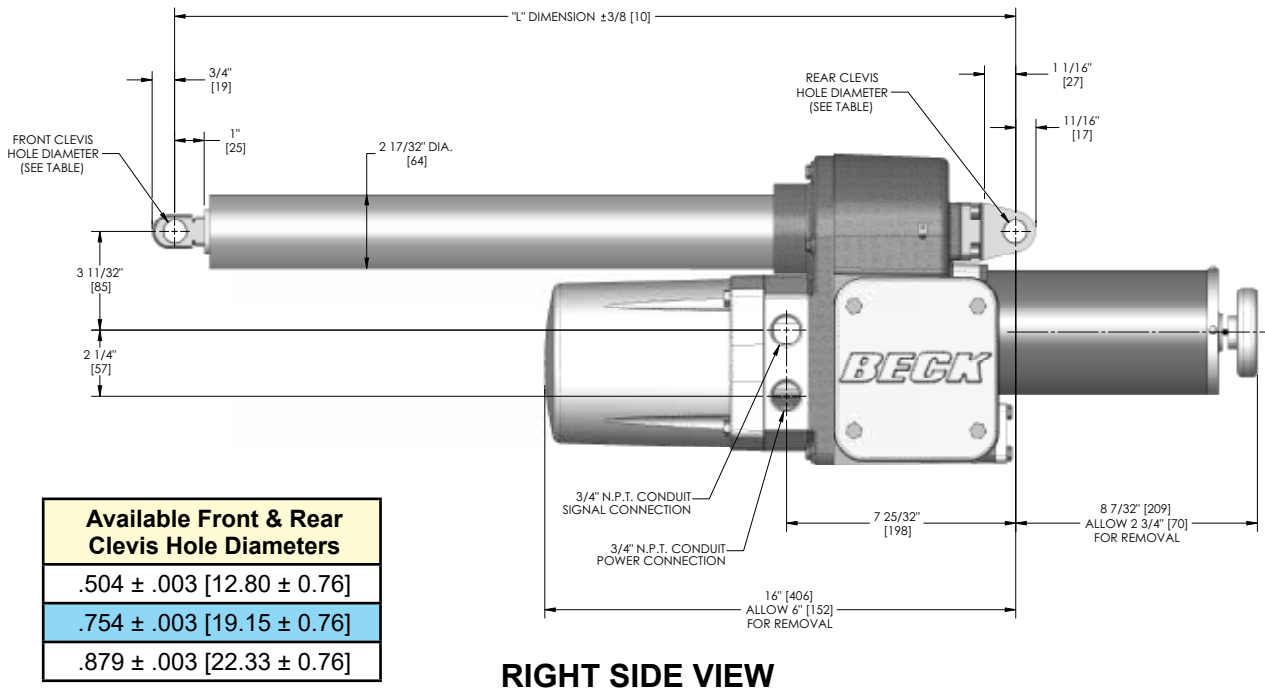

Available Front & Rear Clevis Hole Diameters
.504 ± .003 [12.80 ± 0.76]
.754 ± .003 [19.15 ± 0.76]
.879 ± .003 [22.33 ± 0.76]

RIGHT SIDE VIEW

Note:

Front mounting clevis rotates 360°. Custom rear clevis extensions are available.

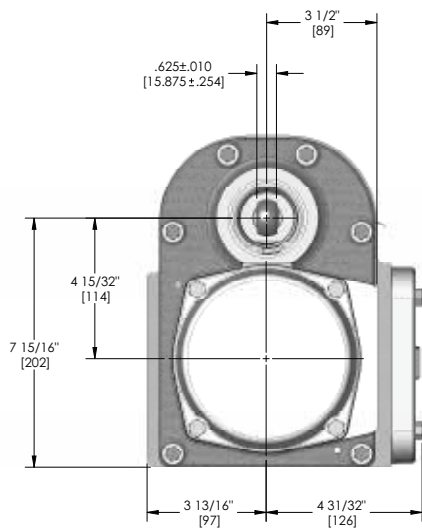

FRONT VIEW

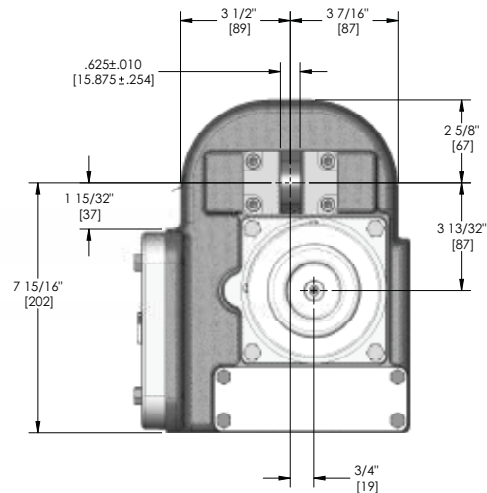

REAR VIEW

Max. Actuator Travel (in) [mm]	Min. Actuator Travel (in) [mm]	"L" Dim. Fully Ret. (in) [mm]	"L" Dim. Fully Ext. (in) [mm]	Approx. Wt. (lbs) [kgs]
8 [203]	5 [127]	18 19/32 [472]	26 19/32 [675]	64 [29]
12 [305]	7 [178]	22 19/32 [574]	34 19/32 [879]	66 [30]
18 [457]	11 [279]	28 19/32 [726]	46 19/32 [1 183]	69 [31]

INSTALLATION

POWER AND SIGNAL WIRING

The Group 42 actuator has a pair of 3/4" NPT threaded holes for signal and power conduit connection. Temporary plugs are installed in the conduit entrances at the factory for shipping only and are not intended for permanent use.

Conduits should be routed from below the actuator so that condensation and other contaminants flow away from the conduit. Prior to actuator operation, all conduit entrances must be properly sealed in accordance with National Standards or Regulatory Authorities.

Power and signal wires must be routed to the actuator separately and be either shielded cables or installed in conductive conduit and/or cable trays.

All signal and power connections are made on the terminal board. Typical wiring connections for each Group 42 control option are described on the following pages. A specific wiring diagram is affixed to each actuator shipped.

All actuators are furnished with two auxiliary switches. Wiring connections for these are described separately. In addition, a safety ground is required for all actuators and is located on the baseplate of the control module.

NOTE: Customer wiring inside the control module must be properly dressed and routed to prevent damage to wires from the control module cover.

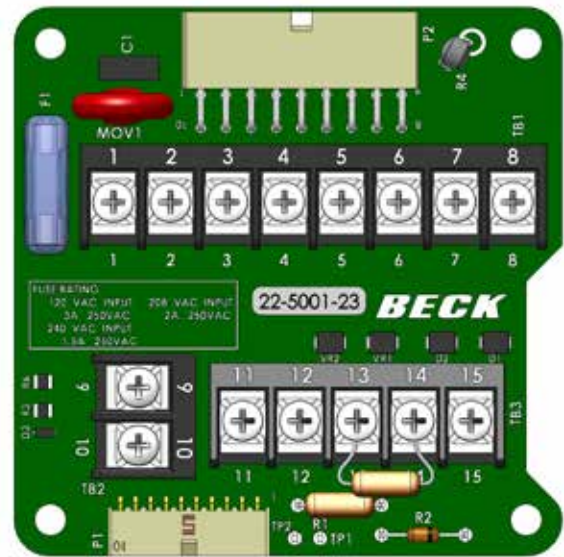

(Option 7 Terminal Board Shown)

Figure 1

Option 7, Modulating

Analog Position Control with Loop Powered Position Feedback Signal

Customer must supply two wires to power the actuator: One 120 V ac line (terminal 1), and one neutral (terminal 2). Customer must supply two wires for the analog input control signal: Connect to terminal 11 (-) and to terminal 12 (+). The loop powered position feedback signal must be connected to a "2-wire" type analog input that provides a dc voltage over the signal wires (a dc voltage power supply must be wired in series with the signal wiring). If the dc supply is 24 to 35 volts, connect to terminal 14 (-) and to terminal 15 (+). If the dc power supply is 36 to 45 volts, reverse polarity and connect to terminal 14 (+) and to terminal 15 (-).

Analog Position Control with Actuator Powered Position Feedback Signal

Customer must supply two wires to power the actuator: One 120 V ac line (terminal 1), and one neutral (terminal 2). Customer must supply two wires for analog control: Connect to terminal 11 (-) and to terminal 12 (+). Customer may supply two additional wires to monitor the analog position feedback signal: Connect to terminal 13 (-) and to terminal 14 (+). The actuator's feedback circuit power supply is derived from the 120 V ac line, therefore the feedback signal must be wired to a "4-wire" type, non-powered analog input.

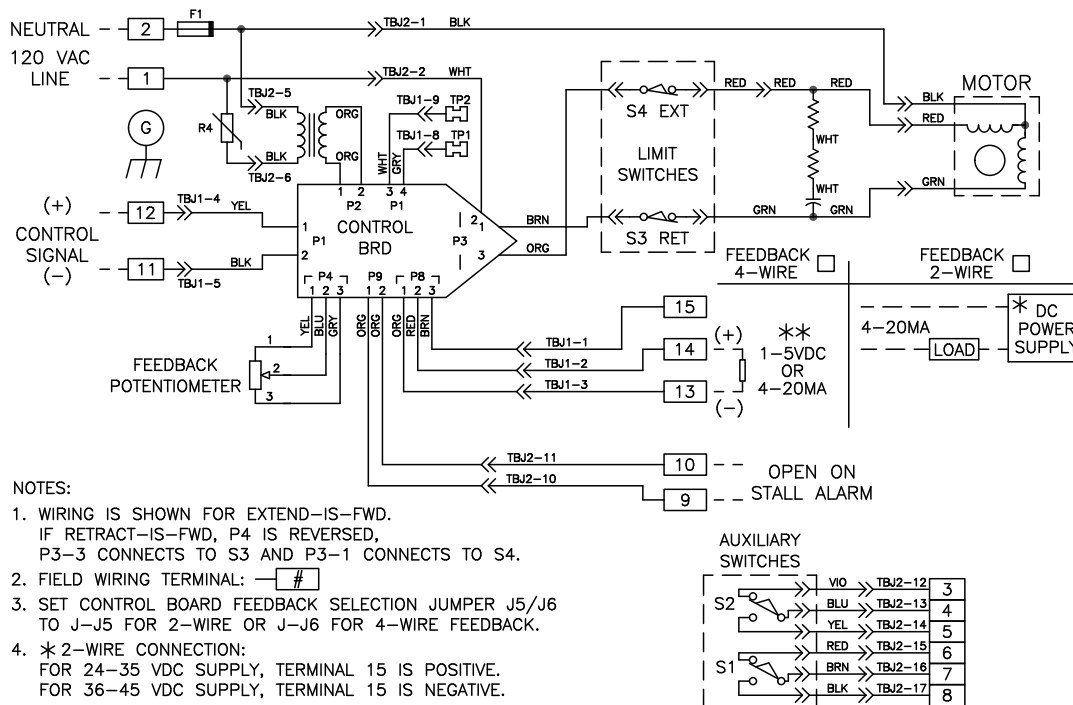

Typical Wiring Diagram (Option 7)

Auxiliary Switches

Customer connections to the auxiliary switches are on the terminal board. Switch 1 connects to terminals 6, 7 and 8. Switch 2 connects to terminals 3, 4 and 5. Each switch is form C, rated for 1 amp at 120 V ac. There is no electrical connection between the two switches. S1 is factory set to operate 2% of the travel range before the Retract travel limit. S2 is factory set to operate 2% before the Extend travel limit. See page 13 for additional information about setting the auxiliary switches.

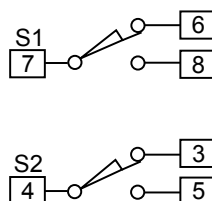

INSTALLATION

Option 5, Modulating

Direct AC Control with Loop Powered Position Feedback Signal

Customer must supply three wires to directly control the actuator motor direction: One 120 V ac line to run Extend (terminal 10), one 120 V ac line to run Retract (terminal 9), and one neutral (terminal 2). Customer may supply two additional wires to monitor a loop powered position feedback signal. The loop powered position feedback signal must be connected to a "2-wire" type analog input that provides a dc voltage over the signal wires (a dc voltage power supply must be wired in series with the signal wiring). If the dc supply is 24 to 35 volts, connect to terminal 14 (-) and to terminal 15 (+). If the dc supply is 36 to 45 volts, reverse polarity and connect to terminal 14 (+) and to terminal 15 (-).

Direct AC Control with Actuator Powered Position Feedback Signal

Customer must supply three wires to directly control the actuator motor direction: One 120 V ac line to run Extend (terminal 10), one 120 V ac line to run Retract (terminal 9), and one neutral (terminal 2). Customer may supply two additional wires to monitor the analog position feedback signal: Connect to terminal 13 (-) and to terminal 14 (+). If position feedback monitoring is desired, a 120 V ac line must be connected to terminal 1. The actuator's feedback circuit power supply is derived from this 120 V ac line, therefore the feedback signal must be wired to a "4-wire" type, non-powered analog input.

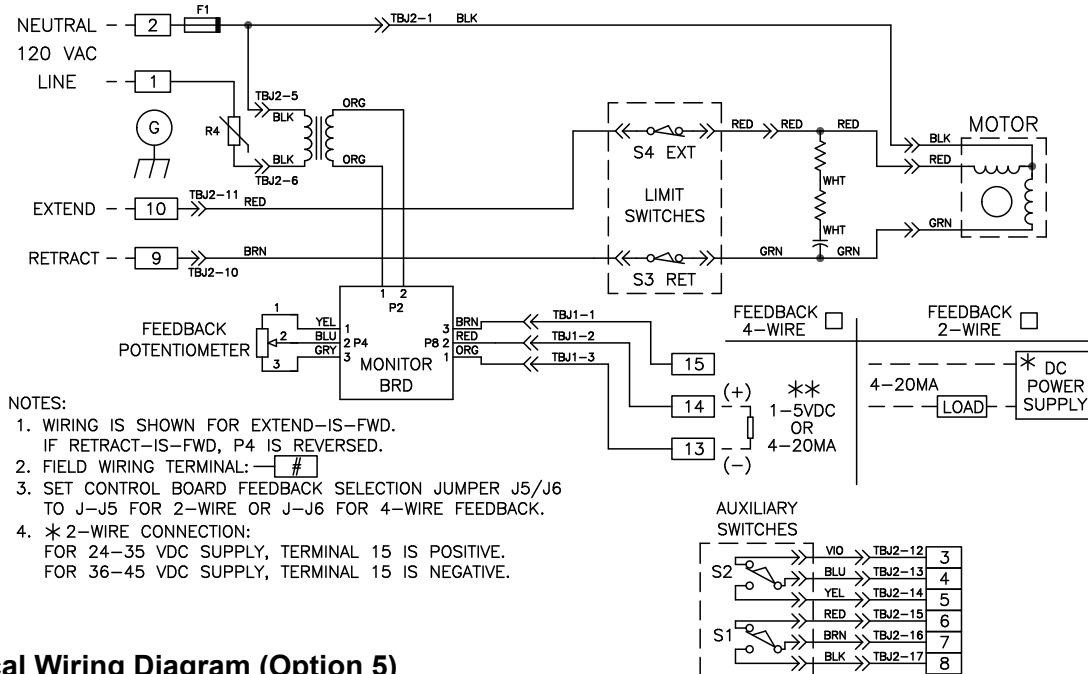

Typical Wiring Diagram (Option 5)

Option 3, Open/Close

Direct AC Control

Customer must supply three wires to directly control the actuator motor direction: one 120 V ac line to run Extend (terminal 10), one 120 V ac line to run Retract (terminal 9) and one neutral (terminal 2).

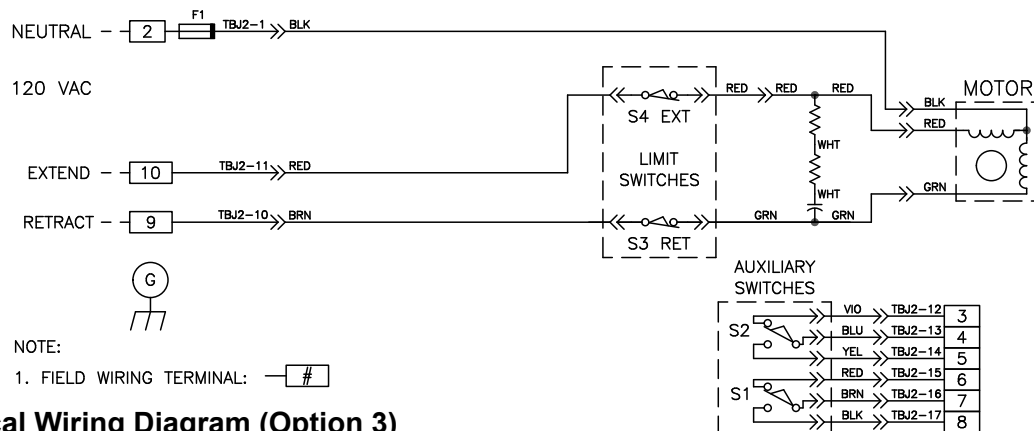

Typical Wiring Diagram (Option 3)

SAFETY PRECAUTIONS



WARNING

Installation and service instructions are for use by qualified personnel only. To avoid injury and electric shock, do not perform any servicing other than that contained in this manual. Please read and understand the appropriate sections in this manual before attempting to install or operate your actuator.



CAUTION

Hot surfaces! Surfaces of equipment may be at an elevated temperature depending on operating conditions and environment. Allow to cool before servicing.

STORAGE INFORMATION

Beck actuators should be stored in their shipping cartons in a clean, dry area.

If it is necessary to store actuators outdoors for a long period of time, they should be stored above ground and covered with a waterproof cover. Do not stack cartons. Stored actuators should be checked periodically to ensure no condensation has formed in electronic and terminal compartments. Moisture damage while in storage is not covered by warranty.

UNPACKING

Group 42 actuators are shipped in standardized cardboard shipping containers and secured to a wooden platform.

INSTALLATION—ELECTRICAL

NOTE: All Beck actuators are shipped from the factory ready for installation; no electrical adjustments are required before placing them in operation. Each actuator is set up and calibrated to the customer's specifications that were written into the equipment order.

Two N.P.T. conduit connections are provided for power and signal wiring to the actuator. One 3/4" conduit is provided for signal wiring connections, and the other 3/4" conduit is provided for power and auxiliary switch connections. A sealant must be used on threaded conduit connections to keep moisture out. Conduits should be routed from below the actuator so that condensation and other contaminants entering the conduit cannot enter the actuator.

Power and signal wires must be routed to the actuator separately and be either shielded cables or installed in conductive conduit and/or cable trays.

Shielded, twisted pair cables should be used for signal connections to avoid being affected by electrical noise. These signal wires, based on Noise Susceptibility Level (NSL) per IEEE-518, fall into the level 1 classification. A braided shield will be more effective than a wrapped foil shield. Signal wire shields should be connected to the actuator casting grounding screw. If grounding at the signal source is required, then the shield should not be grounded at the actuator. Raceways such as conduits and trays have to be grounded at both ends to properly meet immunity requirements.

A large, clearly labeled terminal block in the actuator is enclosed in a separate, gasketed metal enclosure. Terminals will accommodate up to 12 AWG (3.31 mm²) wiring.



CAUTION

Always close covers immediately after installation or service to prevent moisture or other foreign matter from entering the actuator.

Refer to the wiring diagram furnished with your Beck actuator for proper AC power and signal connections. It is advisable to provide normal short circuit protection on the AC power line. A copy of the wiring diagram is shipped with each actuator and is fastened to the inside of the terminal block cover. If there is no wiring diagram available, you may obtain a copy from Beck by providing the serial number of your actuator.

Your Beck actuator has been supplied to match the signal source in your control loop. If it does not match, a 250 ohm input resistor may be added or removed to obtain the proper match. Consult the factory for details.

For maximum safety, and to comply with national and international standards, the Beck actuator body is required to be grounded. Use one of the two grounding terminals in the wiring compartment of the actuator to make this connection. Wire size 12 AWG (3.31 mm²) is recommended for this purpose.

CONDUIT ENTRIES

Conduits are provided for power and signal wiring. Temporary plugs are installed in the conduits at the factory for shipping only and are not intended for permanent use. Prior to actuator operation, all conduit entrances must be properly sealed in accordance with National Standards or Regulatory Authorities.

INSTALLATION

START-UP INSTRUCTIONS

After wiring and mounting, the actuator is ready to be tested for proper operation.

Turn on the power supply.

For Options 3 & 5, turn on the actuator 120 V ac control signal and observe that the output shaft travels through its desired stroke and moves in the proper direction. If the direction of travel is wrong, check the wiring connections and verify that the control signal is correct at the actuator. If the wiring and signal are correct, then reverse the direction of shaft travel. See page 14 for instructions.

For Option 7, set the Auto-Manual switch (S2) to Manual. Using the Handswitch (S1), run the actuator through its full stroke, first extend then retract (for location of switches S1 and S2, see Figure 7, page 18). Observe that the output shaft travels through its desired stroke. Note that the "F" (extend) and "R" (retract) LEDs on the control board light to indicate the direction of travel of the output shaft. The LEDs remain lit when the unit is stopped by the travel limit switches.

Set the Auto-Manual switch to Auto mode and operate the actuator by varying the control signal. Check that the output shaft travels in the proper direction for a change in control signal. If it does not, first check the wiring connections and verify that the control signal is correct at the actuator. If the wiring and signal are correct, then reverse the direction of travel. See page 14 for instructions. Note that the "F" (extend) and "R" (retract) LEDs light to indicate the direction the actuator output shaft is moving and are not lit when the shaft stops and the input and feedback signals are in balance.

When satisfied that the actuator travel is correct with reference to the input signals, the unit is ready to be placed in operation.

CALIBRATION

NOTE: Beck actuators are shipped ready for installation—no calibration or switch adjustments are required. The procedures below are provided in the event that the application requirements are different from those originally specified.



CAUTION

Do not attach the meter or attempt to adjust the switch cams until the actuator is disconnected from the line voltage and auxiliary switches are disconnected from external power sources.

CALIBRATION HIERARCHY

The calibration hierarchy provides the chronological order for performing calibration procedures. If, for some reason, any or all of the calibration procedures are required, they should be performed in the order outlined below:

- STEP 1: Adjust travel and auxiliary switches (see pages 11–13).
- STEP 2: Change direction of travel (see page 15).
- STEP 3: (Options 5 & 7 only). Calibrate the position feedback output signal (see page 17).
- STEP 4: (Option 7 only) Calibrate the demand input signal (see page 18).

TRAVEL LIMIT SWITCHES (S3, S4)

All Group 42 actuators are shipped from the factory with the travel limit switches (S3 and S4) adjusted to provide the full rated stroke range unless a reduced stroke is specified at the time of order. No adjustments are necessary unless the full stroke length needs to be shortened to meet different application requirements.

The travel limit switches are labeled S3 and S4, and correspond to fully retracted and fully extended positions respectively. These switches must be set inside the mechanical stop limits to prevent the actuator from stalling against the mechanical stops. Depending on the control option ordered, these switches serve slightly different purposes.

Control option 3 (42-103): S3 and S4 define the exact fully retracted and fully extended end of travel point.

Control options 5 & 7 (42-105, 42-107): S3 and S4 provide electrical over-travel protection. In these versions, the control electronics position the output and determine the fully retracted and extended positions during normal operation.

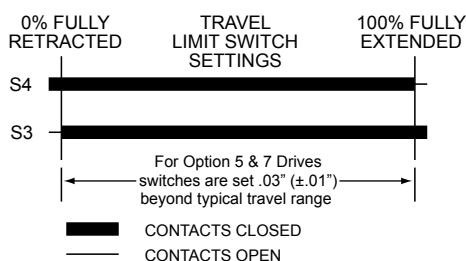

Setting the Retract Travel Limit Switch (S3)

1. Remove the control module cover.
2. Retract the output shaft to the desired travel limit. For Options 3 & 5, skip to step 3. For Option 7: De-energize the motor by turning toggle switch S1 (see Fig. 3) to stop (center position). Turn the Handwheel until the position feedback signal (measured across terminals 14 (+) & 13 (–)) decreases by $.005 \pm .001$ mA (1.25 mV $\pm .25$). The $.005$ mA is the over-travel range. NOTE: If direction of travel is set for retract on increasing demand, then turn the Handwheel until the output signal increases by $.005 \pm .001$ mA ($1.25 \pm .25$ mV).
3. Disconnect the power from the actuator.
4. a. For actuators with Option 3 or 5, connect the continuity meter across terminals 2 and 9. Rotate the cam (see Fig. 2 next page) until the meter shows an increase in resistance from approx. 100 ohms to more than 1 M ohms (switch contacts open, switch clicks).
 - b. For actuators with Option 7, remove the cable tie holding the switch wires, remove the two wires from the retract limit switch (second from the top), and attach the meter across these contacts. Rotate the cam (see Fig. 3 next page for method only--shows S4 connected) until the meter shows no continuity (switch contacts open, switch clicks).
5. Disconnect the meter and reconnect switch wires and actuator power.
6. Extend the output shaft away from the retract travel limit. Note the direction of rotation of the lobe of the cam. The correct cam lobe motion is away from the switch lever and the switch lever should be on the lower part of the cam. If this is not correct, return to step 2 and reset the cam to the proper orientation.
7. Retract the output shaft to the desired travel limit. If the desired stopping point is reached, the switch is properly set.
8. For Option 7, redress the switch wires and secure to the control board standoff with a cable tie.
9. Replace the control module cover.

CALIBRATION

Setting the Extend Travel Limit Switch (S4)

1. Remove the control module cover.
2. Extend the output shaft to the desired travel limit. For Options 3 & 5, skip to step 3. For Option 7: De-energize the motor by turning toggle switch S1 (see Fig. 3) to stop (center position). Turn the Handwheel until the position feedback signal (measured across terminals 14 (+) & 13 (-)) increases by $.005 \pm .001$ mA (1.25 mV \pm .25). The .005 mA is the over-travel range. NOTE: If direction of travel is set for retract on increasing demand, then turn the Handwheel until the output signal decreases by $.005 \pm .001$ mA (1.25 \pm .25 mV).
3. Disconnect the power from the actuator.
4.
 - a. For actuators with Option 3 or 5, connect the continuity meter across terminals 2 and 10. Rotate the cam (see Fig. 2 at right) until the meter shows an increase in resistance from approx. 100 ohms to more than 1 M ohms (switch contacts open, switch clicks).
 - b. For actuators with Option 7, remove the cable tie holding the switch wires, remove the two wires from the extend limit switch (top switch), and attach the meter across these contacts. See Fig. 3 at right. Rotate the cam (see Fig. 2 at right) until the meter shows no continuity (switch contacts open, switch clicks).
5. Disconnect the meter and reconnect switch wires and actuator power.
6. Retract the output shaft and note the direction that the Retract limit switch cam rotates. The correct cam lobe motion is away from the switch lever and the switch lever should be on the lower part of the cam. If this is not correct, return to step 2 and reset the cam to the proper orientation.
7. Retract the output shaft to the desired travel limit. If the desired stopping point is reached, the switch is properly set.
8. For Option 7, redress the switch wires and secure to the control board standoff with a cable tie.
9. Replace the control module cover.

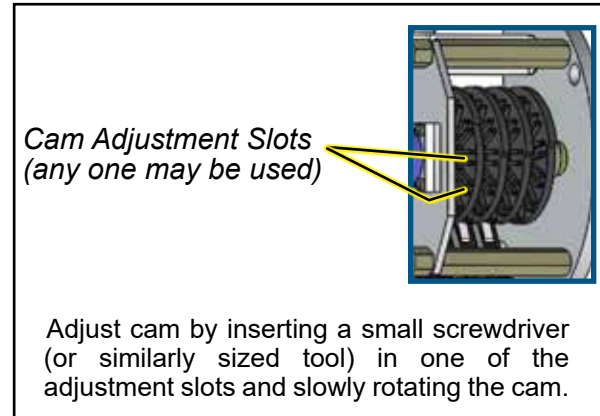

Cam Adjustment

Figure 2

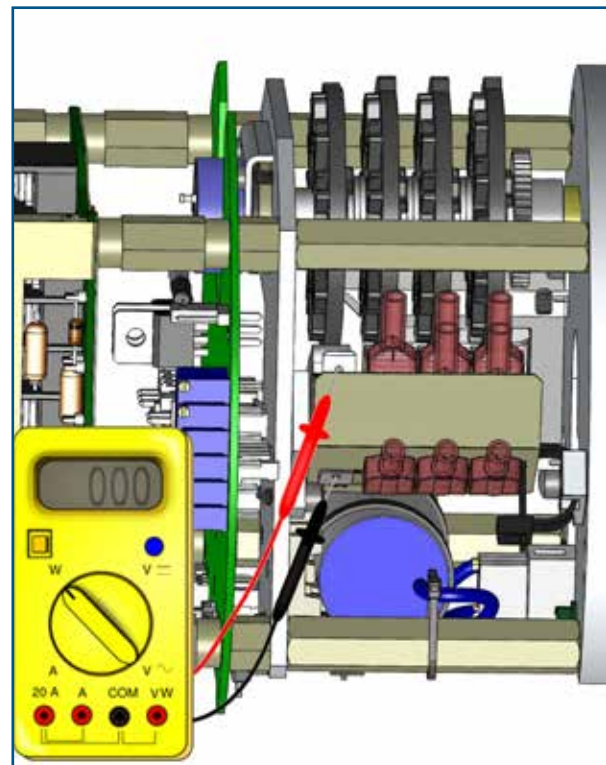

**Meter connections for S4 switch
(Push on connectors shown
without wires for clarity)**

Figure 3

SETTING AUXILIARY SWITCHES (S1 & S2)

All versions of Group 42 actuators referenced in this manual are shipped with two auxiliary switches. They may be set at any point in the active range of actuator travel. Unless otherwise specified at time of order, these switches are factory set as follows:

Auxiliary switch S1 is set approximately 2% (4.32 mA feedback) before the retract limit.

Auxiliary switch S2 is set approximately 2% (19.68 mA feedback) before the extend limit.

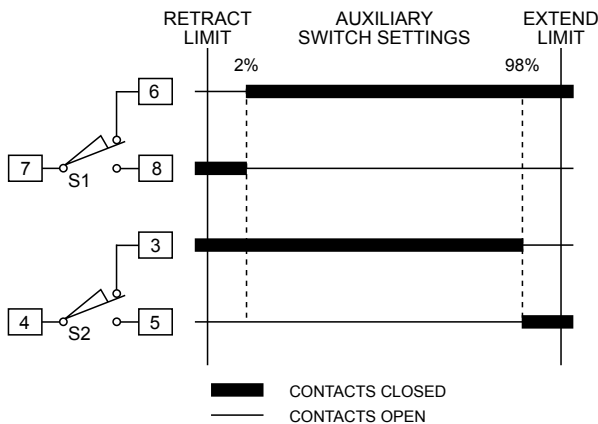

The auxiliary switches are opened and closed by cams that are driven by the actuator output shaft. Setting the switch position involves moving the actuator output shaft to the desired position and adjusting the cam so that it just actuates the switch at that point.



CAUTION

Do not attach the meter or attempt to adjust the switch cams until the actuator is disconnected from the line voltage and auxiliary switches are disconnected from external power sources.

The following procedure recommends the use of a continuity meter to determine when the auxiliary switch opens or closes. If such a meter is not available, it is possible to hear the switch click as the contacts open and close.

1. Remove the control module cover.
2. Move the output shaft to the desired switch position.
3. Disconnect power from the actuator.
4. Connect the continuity meter across the normally closed terminal on the terminal board (terminals 6 and 7 for S1, and 3 and 4 for S2). Adjust the cam until the meter shows no continuity (switch contacts open, switch clicks). See Fig. 2, page 12.
5. Disconnect the meter and reconnect actuator power.
6. Extend/Retract the output shaft in the direction away from the switch position. Note the direction of rotation of the lobe of the cam. The correct cam lobe motion is away from the switch lever and the switch lever should be on the lower part of the cam. If this is not correct, return to step 2 and reset the cam to the proper orientation.
7. Reconnect the meter and actuator power.
8. Extend/Retract the output shaft again to the desired switch position. If the contacts close, the switch is properly set.
9. Replace the control module cover.

CALIBRATION

CHANGING OUTPUT SHAFT DIRECTION OF TRAVEL

Direction of travel is defined as the direction of output shaft travel produced by an increasing signal. Direction of travel is determined by looking at the end of the output shaft. Unless otherwise specified at the time of order, the factory set output shaft travel is to extend in response to an increasing signal.

The following procedure should be followed to check or change the direction of travel of the output shaft.

This is up to a three procedure process depending on the actuator control option. The procedures are as follows:

1. Interchange limit switch wires.
2. Calibrate position feedback signal.
3. Test/calibrate the Demand input signal.



CAUTION

Be sure the actuator is disconnected from the line voltage and the auxiliary switches are disconnected from the external power sources before proceeding with direction change procedure.

Interchange Limit Switch Wires

1. Remove the control module cover.
2. To reverse the output shaft direction of travel, the wires to the common terminals of travel limit switches S3 and S4 must be interchanged. The common terminals are those located furthest from the switch labels and nearest to the power transformer (see Figure 4, this page).
3. For extend output shaft travel on an increasing signal, the orange wire must be on the common terminal of S4 and the brown wire on the common terminal of S3.
4. For retract output shaft travel on an increasing signal, the brown wire must be on the common terminal of S4 and the orange wire must be on the common terminal of S3.
5. Locate plug P4 on the control board. It is a three wire plug with a grey, blue and yellow wire attached to it. See Figure 6, page 17, for the location of plug P4.

6. For extend output shaft travel on an increasing signal, plug P4 must be attached to the terminal labeled CW. Note that this is a locking type plug and must be located properly in its receptacle. The tapered side of the plug must be against the tapered side of the receptacle. See Option 5 or 7 wiring diagram, page 7 or 8.
7. For retract output shaft travel on an increasing signal, this plug must be attached to the terminal labeled CCW.
8. If the direction of travel of the output shaft is changed; the feedback signal, the feedback potentiometer, and (for Option 7) the input signal must be recalibrated. See instructions beginning on page 15.
9. End of procedure for the control option 3 actuator. For options 5 and 7, continue to Feedback signal calibration procedure (page 16).

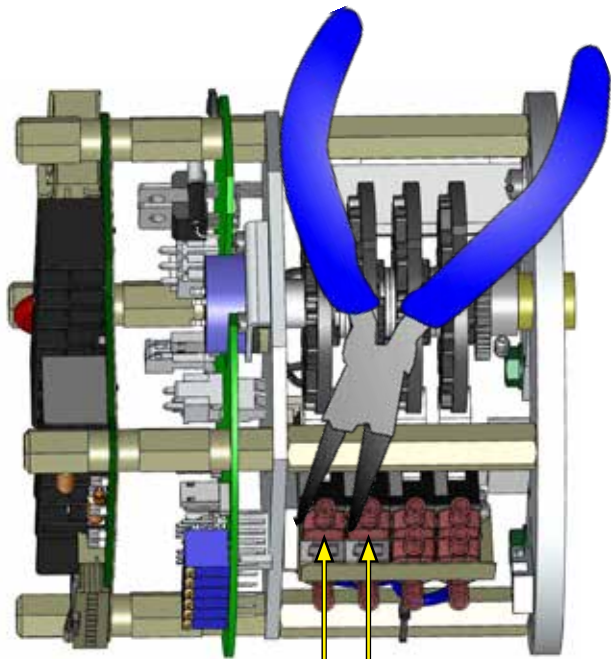

**Interchange the limit switch wires
(Push on connectors shown
without wires for clarity)**

Figure 4

FEEDBACK SIGNAL OPTIONS (OPTIONS 5 & 7 ONLY)

The feedback signal is an analog voltage or current signal proportional to the position of the actuator's output shaft. It may be used for remote position indication or for automatic control loop feedback. Actuators with Options 5 or 7 may be field connected to function as a two wire transmitter or as a four wire active current source. This circuit configuration is determined by the position of Jumper Plug J5/J6 located on the control board (J-J5 for 2-wire, J-J6 for 4-wire). See Figure 6 or 7 for J5/J6 location. Unless otherwise specified at the time of order, all Group 42 actuators are shipped with the feedback circuit configured as a 4-wire system. Also, all Option 7 models are shipped with a 249 ohm resistor (R5) mounted between output signal terminals 13 and 14. This resistor is used to ensure proper operation of the control board when the feedback signal is not connected to a control room indicator. A summary of position feedback options, output signal ranges and control board and terminal board part numbers is provided in TABLE 1, below.

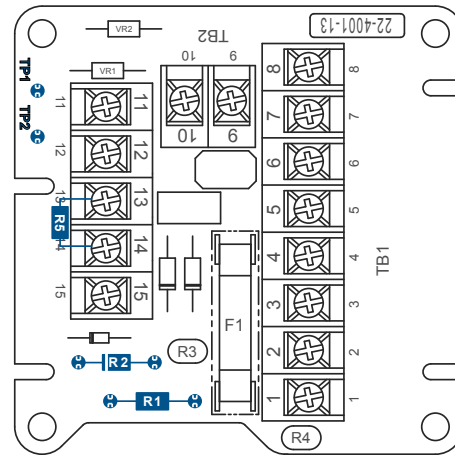

Option 7 Terminal Board

Figure 5

feedback calibrated for full output shaft travel unless otherwise specified at time of order. Feedback signal calibration is necessary to ensure that the signal current or voltage correctly corresponds to the actuator output shaft position.

CHANGING FEEDBACK SIGNAL TYPE

The feedback signal may be specified as 4-20 milliamps or 1-5 volts when ordered or it may be changed at installation using the following methods:

FOR OPTION 7: To convert a 4-20 milliamp configuration to 1-5 volts, remove the diode from

Continued

FEEDBACK SIGNAL & CALIBRATION

For 4-wire feedback only

All Group 42 actuators are shipped with the

TABLE 1

Fdbk. System	Control Option	Signal Config.		Ext. Pwr. Supply	Fdbk. Sig. Conn.		Jumper Loc.	Max. Ext. Load	Input Res. R1	Fdbk. Res. R2	Input Res. Ω	Output Res. Ω	Meter Conn. for Signal Cal.	
		Input	Output		Plus	Minus							Plus	Minus
2-Wire	5	120 V	4-20 mA	<35 V	15	14	J-J5	300Ω	--	Diode	--	>1 M	14	Cust. - (Series)
2-Wire	5	120 V	4-20 mA	>36 V	14	15	J-J5	800Ω	--	Open	--	>1 M	15	Cust. - (Series)
2-Wire	7	1-5 V	4-20 mA	<35 V	15	14	J-J5	300Ω	--	Diode	2 M	>1 M	14	Cust. - (Series)
2-Wire	7	1-5 V	4-20 mA	>36 V	14	15	J-J5	800Ω	--	Open	2 M	>1 M	15	Cust. - (Series)
2-Wire	7	4-20 mA	4-20 mA	<35 V	15	14	J-J5	300Ω	249Ω	Diode	249	>1 M	14	Cust. - (Series)
2-Wire	7	4-20 mA	4-20 mA	>36 V	14	15	J-J5	800Ω	249Ω	Open	249	>1 M	15	Cust. - (Series)
*4-Wire	5	120 V	4-20 mA	120 V	14	13	J-J6	500Ω	--	Diode	--	>1 M	14	Cust. + (Series)
4-Wire	7	1-5 V	4-20 mA	120 V	14	13	J-J6	500Ω	--	Diode	2 M	>1 M	14	Cust. + (Series)
*4-Wire	7	4-20 mA	4-20 mA	120 V	14	13	J-J6	500Ω	249Ω	Diode	249	>1 M	14	Cust. + (Series)
<u>Voltmeter Connection</u>														
4-Wire	5	120 V	1-5 V	120 V	14	13	J-J6	0.4 mA	--	249Ω	--	249	14	13 (Parallel)
4-Wire	7	1-5 V	1-5 V	120 V	14	13	J-J6	0.4 mA	--	249Ω	2 M	249	14	13 (Parallel)
4-Wire	7	4-20 mA	1-5 V	120 V	14	13	J-J6	0.4 mA	249Ω	249Ω	2 M	249	14	13 (Parallel)

Control Option 5 = Control Board 22-4001-10 & Terminal Board 22-4001-07.

Control Option 7 = Control Board 22-4001-17 or 22-5001-21 (22-5001-21 supersedes 22-4001-17) & Terminal Board 22-4001-13.

Note: For Split Range Operation, 1-5 V dc input can be calibrated 1-3 or 3-5 V dc. 4-20 mA input can be calibrated 4-12 or 12-20 mA.

Maximum Input Common Mode Range +15 V to -5 V as measured from Terminal 11 to Terminal 13.

*Typical for most applications.

CALIBRATION

CHANGING FEEDBACK SIGNAL TYPE, CONT'D

position R2 on the terminal board and replace with a 249 ohm resistor. To convert a 1-5 volt configuration to 4-20 milliamps, remove the 249 ohm resistor and replace it with a 12 volt zener diode, Beck Part Number 13-2550-04. See Figure 5, page 15, for location of resistor R2.

FOR OPTION 5: To convert a 4-20 milliamp configuration to 1-5 volts, install a 249 ohm resistor in position R2. To convert a 1-5 volt configuration to 4-20 milliamps, remove the 249 ohm resistor from position R2.

FEEDBACK POTENTIOMETER AND SIGNAL CALIBRATION PROCEDURE

When properly adjusted, the feedback signal will be 20 milliamps (5 volts) with the actuator output shaft in the 100% (maximum input signal) position. At the 50% travel position, the signal should be 12 milliamps (3 volts) and at 0% (minimum input signal) 4 milliamps (1 volt). NOTE: The endpoint values are opposite if the direction of travel is set to retract on an increasing signal.

The calibration procedure requires checking and/or setting the feedback potentiometer and two trim potentiometers located on the control board. The following paragraphs describe the procedure to check and set feedback signal calibration.

NOTE: The travel limit switches must be properly adjusted before the feedback signal is calibrated. The feedback signal must be calibrated before the input signal can be calibrated.

Tools required for calibration:

- mA/V dc voltmeter
- 3/32 inch screwdriver
- Large screwdriver

TABLE 1 lists the meter connections required for the calibration procedure.

Figures 6 and 7 show the location of the jumper plug, feedback potentiometer, trim potentiometers, the Forward/Reverse and Manual/Automatic switches and plug P4 on the control boards.

Orienting the Potentiometer

(Note: Only use Steps 2–12 when changing direction of travel)

1. Remove the control module cover.
2. Position the actuator output shaft to the end of travel that corresponds to 4 mA (i.e., to the fully retracted position if the actuator travel is set to extend on an increasing demand signal, or to the fully extended position if the actuator travel

is set to retract). Allow the over-travel limit switch to de-energize the motor at the limit.

3. Set the Forward/Reverse toggle switch to STOP (center position), Option 7 Control Board only.
4. Set the Manual/Automatic toggle switch to "M" (Manual), Option 7 Control Board only.
5. Connect the meter to read the feedback signal.

FOR CURRENT FEEDBACK APPLICATIONS:

Connect the meter in series with the plus signal line of the control room indicator and the plus signal position (terminal 14 or 15; see TABLE 1 for correct meter polarity or reference the wiring diagram inside the control cover).

FOR VOLTAGE FEEDBACK APPLICATIONS:

Connect the meter across the signal terminals 13 and 14. Terminal 14 is positive.

FOR INSTALLATIONS WITH NO REMOTE INDICATOR:

Remove the resistor from between terminals 13 and 14 and connect the meter across these terminals. Terminal 14 is positive.

6. Reverse plug connection P4. Note that plug P4 is a locking type plug and must be located properly in its receptacle. The tapered side of the plug must be against the tapered side of the receptacle. See Figure 6, page 17 for the location of the plug. NOTE: On plug P4, CW = Extend and CCW = Retract.
 7. If the mechanical position of the feedback potentiometer has not been set:
 - a. Move the actuator output shaft to the (minimum input signal) position.
 - b. Disconnect all power to the actuator.
 - c. Loosen feedback potentiometer clamp screws.
 8. Turn trim potentiometer R38 clockwise 20 turns (to limit), then rotate it 8 full turns counterclockwise.
 9. Turn trim potentiometer R46 clockwise 20 turns (to limit), then rotate it 8 full turns counterclockwise.
 10. Reconnect actuator power.
 11. Turn the feedback potentiometer until the output signal reads 20 + 0.5 milliamps (5 + 0.1 volts on units configured for voltage output).
 12. Tighten the feedback potentiometer clamp screws to hold the potentiometer in position. The potentiometer orientation is now complete.
- ### Signal Calibration
13. Turn trim potentiometer R46 counterclockwise until the output signal reads 3.95 mA \pm .001 mA (1 volt on units configured for voltage output).
 14. Move the output shaft towards the (maximum input signal) position.

15. Position the actuator output shaft to the end of travel limit that corresponds to 20 mA (i.e., to the fully extended position if the actuator travel is set to extend on an increasing demand signal, or to the fully retracted position if the travel is set to retract). Allow the over-travel limit switch to de-energize the motor at the limit.
16. Turn trim potentiometer R38 counterclockwise until the output signal is $20.05 \text{ mA} \pm .001 \text{ mA}$ (5 volts on units configured for voltage output).
17. Repeat steps 15 through 16 until the feedback signal is calibrated. Adjusting R38 and R46 clockwise increases the signal while counterclockwise decreases the signal.
18. Reinstall resistor between terminals 13 and 14 (if used).

NOTE: The input signal is calibrated relative to the feedback signal. Therefore the shaft travel limit switches must be properly adjusted and the feedback signal calibrated before the input signal can be calibrated.

DEMAND INPUT SIGNAL CALIBRATION (Option 7 only)

NOTE (Option 7): All actuators are fully calibrated at the factory and should require no adjustment; however, if necessary, calibration may be tested as follows:

Apply 4.00 mA; actuator should position at $4.00 \text{ mA} \pm .02 \text{ mA}$.

Apply 20.00 mA; actuator should position at $20.00 \text{ mA} \pm .02 \text{ mA}$.

If adjustments are required, see below.

Input signal calibration is necessary to ensure that the input signal correctly corresponds to the position of the actuator output shaft.

Unless otherwise specified at the time of order, all Group 42 actuators are shipped with the input signal calibrated for full output shaft travel and the input signal range set to 4 to 20 milliamps. A 1 to 5 volt input signal may be specified at time of order or changed at installation. To convert a 4-20 milliamp input configuration to 1-5 volts, remove input resistor R1 from the terminal board. To convert a 1-5 volt input configuration to 4-20 milliamps, install a 249 ohm resistor in position R1. See Figure 5, page 15 for the location of R1.

When properly adjusted, the actuator output shaft will be in the fully extended position when the input signal is 20 milliamps (5 volts). At 50% travel, the input signal should be 12 milliamps (3 volts) and at fully retracted, 4 milliamps (1 volt).

Split signal operation is also possible. The control board can be adjusted to produce full actuator travel with 50% of the input signal, permitting two actuators to respond independently from the same signal source. Split signal ranges are:

4 to 12 milliamps (1 to 3 volts)

12 to 20 milliamps (3 to 5 volts)

It is also possible to calibrate the control board to give a span anywhere between 8 and 16 milliamps (2 to 4 volts), with the minimum signal between 4 and 12 milliamps (1 to 3 volts). The maximum input signal may be anywhere between 12 and 20 milliamps (3 to 5 volts) as long as the span is at least 8 milliamps (2 volts).

Tools required for calibration:

mA/V dc voltmeter

3/32 inch screwdriver

Large screwdriver

Table 1 lists the meter connections required for the calibration procedure.

The calibration procedure requires setting two trim potentiometers R13 and R14 on the control board. Figure 7 shows the location of these potentiometers and the Manual/Automatic switches.

1. Remove the control module cover.
2. Set the Manual/Automatic toggle switch to AUTOMATIC.
3. Connect a signal source to terminals 11 and 12, positive to 12.
4. Connect the meter to read the feedback signal in accordance with Table 1, page 15.

Continued

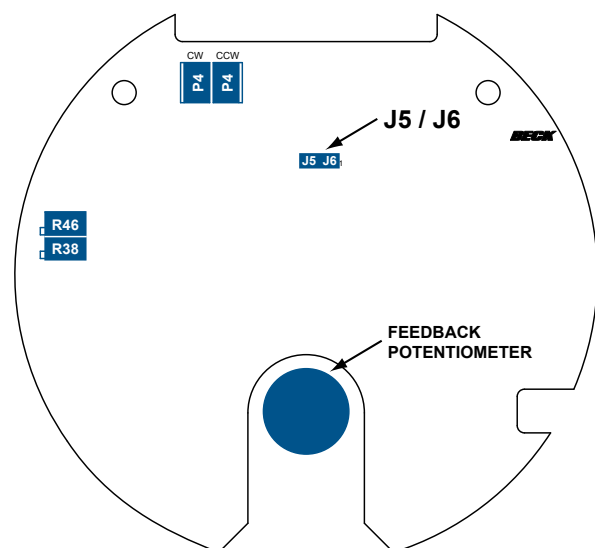

Option 5 Control Board

Figure 6

CALIBRATION

DEMAND INPUT SIGNAL CALIBRATION, CONT'D

FOR INSTALLATIONS WITH NO REMOTE INDICATOR: Remove the resistor from between terminals 13 and 14 and connect the meter across these terminals. Terminal 14 is positive.

5. Connect 120 V ac to terminals 1 and 2.
6. Turn on the 120 V ac power supply.
7. Set the input signal to 100 percent, that is 20 milliamps (5 volts) maximum.
8. If the position feedback is less than 19.98 mA, then trim R13 clockwise. If greater than 20.02 mA, trim R13 counter-clockwise. Trim R13 as required until the output signal is $20.000 \text{ mA} \pm .002 \text{ mA}$ ($5.00 \text{ V} \pm .50 \text{ mV}$).
NOTE: As the output signal approaches 20.00 mA, R13 will become more sensitive; at that point, minor adjustments followed by cycling the demand signal may be required to achieve the desired results.
9. Set the input signal to zero percent, that is 4 milliamps (1 volt).
10. If the position feedback signal is greater than 4.02 mA, then trim R14 counter-clockwise. If less than 3.98 mA, trim R14 clockwise. Trim R14 as required until the output signal is $4.000 \text{ mA} \pm .002 \text{ mA}$ ($1.00 \text{ V} \pm .50 \text{ mV}$).
NOTE: As the output signal approaches 4.00 mA, R14 will become more sensitive; at that point, minor adjustments followed by cycling the demand signal may be required to achieve the desired results.
11. Repeat Steps 7–10 as required.
12. Calibration is complete.
13. Replace the control module cover.

SETTING LOSS OF SIGNAL FUNCTION

Option 7 only

The Loss of Signal (LOS) feature gives the actuator the ability to move the output shaft to a predetermined position if the input signal falls below a predetermined value, as long as ac power is supplied. LOS can function in two ways:

1. Actuator will stay in its last position when the signal was lost.
2. Actuator will move to a position determined by the setting of trim potentiometer R16.

The LOS function will start when the input signal falls below the level set by trim potentiometer R15. The range of adjustment for this input signal trigger level is from zero milliamps input to 8 milliamps (2 volts). The choice of having the actuator stay in place or move to a position is determined by the position of jumper plug J1/J2 on the control board. (J1 moves to a predetermined position, J2 stays in place).

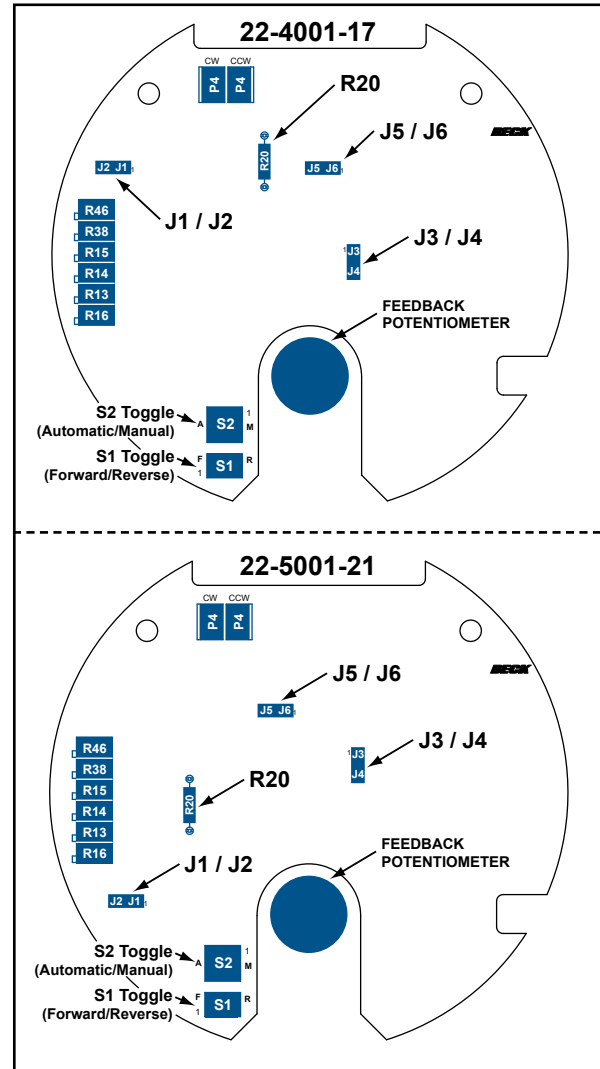

Option 7 Control Boards

Figure 7

Unless otherwise specified at time of order, Group 42 actuators are shipped with the LOS input signal trigger level set to 3.4 milliamps (.85 volts). Jumper plug J1/J2 is set in the J2 or stay in place position. The move to position trim potentiometer (R16) is set so that if this function is chosen the actuator will move to the minimum input signal position.

NOTE: The LOS position is adjusted relative to the feedback signal. The feedback signal must be calibrated before the LOS can be set.

Tools required for setting LOS:
 mA/V dc voltmeter
 3/32 inch screwdriver
 Large screwdriver

Figure 7 shows the location of the jumper plug J1/J2 and the trim potentiometers R15 and R16 on the control board. Figure 5, page 15, shows the location of test points TP1 and TP2.

1. Remove the control module cover.
2. Verify the position of jumper plug J1/J2. Use J1 to select the move to position function or J2 to select the stay in place function.



CAUTION
Never use both J1 and J2—damage will result.

3. Connect 120 V ac to terminals 1 and 2.
4. Turn on 120 V ac power supply.
5. Connect the voltmeter between test points TP1 and TP2. TP2 is positive.
6. Turn trim potentiometer R15 until the desired trigger level is measured on the voltmeter. The voltage scale is:
 - 0 V = 0 milliamps
 - 1 V = 4 milliamps
 - 2 V = 8 milliamps
 Turn the potentiometer clockwise to increase the trigger voltage, counterclockwise to decrease the trigger voltage.
7. Disconnect the input signal (if connected) so that the LOS becomes active.
8. If LOS is set to stay in place, the actuator output shaft will not move.
9. If LOS is set to move to position:
 - Turn trim potentiometer R16 until the desired output shaft position is reached. Turn the potentiometer clockwise to increase the output shaft position, counterclockwise to decrease the output shaft position.
10. Replace the control module cover.

STALL FUNCTION (Model 42-107 Only)

The Stall function for Model 42-107 actuators provides protection for the actuator motor and gearing in the event of a stalled condition. The time to stall is set at 136 seconds, after which power to the motor is turned off. The timer resets automatically when the signal reverses or the Handswitch is moved from Auto to Manual.

The stall time of 136 seconds is set by the factory and requires Jumper J3/J4 on the control board (see Figure 7, page 18) to be set to the J4 position. If this Jumper is set to the J3 position (not recommended), the time to stall will be decreased to 68 seconds, which may be shorter than the full-stroke travel time of some actuators.

R20 Ω	Parallel Resistor Ω	Effective Resistance Ω	Dead- band
1,000,000			1.0%
1,000,000	2,000,000	666,000	1.5%
1,000,000	1,000,000	500,000	2.0%
1,000,000	665,000	400,000	2.5%

DEADBAND ADJUSTMENT

Group 42, Option 7 actuators are shipped with the deadband set to 1% of span to satisfy the requirements of most control systems. If excessive process and/or signal noise is present, the actuator may be subject to unnecessary cycling. It is recommended that excessive noise be reduced at the source in order to prevent unnecessary cycling. This will improve process control and prolong component life.

If it is not possible to eliminate the excessive noise, the actuator's deadband can be widened; however, this will reduce the resolution of the actuator. Widening the deadband can be accomplished by changing the value of resistor R20 on the Control Board (see Figure 7). The recommended procedure is to solder a second resistor in parallel with the existing resistor R20. The new resistance value, recommended parallel resistor and corresponding deadband are listed in the following chart.

SHORT-STROKE OPERATION (Reducing Full Stroke Travel Distance)

Typically, it is best to use the full travel of the actuator in response to the 0–100% Demand input signal. However, some set-ups and applications make it necessary to reduce this response to less than the maximum full travel distance. To reduce the full travel of the actuator (short-stroke), use the following procedure:

First, adjust the Extend Travel Limit Switch (S4) to the setting necessary to accommodate the reduced travel range (see page 12). Note: If necessary, both the Retract (S3) and Extend (S4) Switches may be adjusted.

Next, perform the Feedback Signal Calibration in relation to the new switch setting(s) to complete setting the reduced travel distance (see page 15).

MAINTENANCE

LUBRICATION

The Group 42 actuator is designed so that no field maintenance of the output section is required. The gear train and bearings are permanently lubricated and do not require any relubrication. Field disassembly of the output section is not recommended. If the rotor is removed from the motor it will result in a loss of motor torque that can only be restored by returning the complete output section to the factory to be remagnetized.

COMPONENT REPLACEMENT

The table below lists the components of the Group 42 actuator that are field replaceable. Each of these components is available as a customer replacement kit which includes the component(s), necessary hardware and detailed instructions.

HOW TO ORDER SPARE PARTS

Any customer replacement kit may be purchased for spare parts. Contact your Beck Sales Engineer for recommended replacement parts particular to your application. Parts may be ordered by mail, telephone, fax or e-mail, with the confirming order sent to the factory (see back cover for factory contact information).



WARNING

Ignition Hazard—Do not service in locations made hazardous (classified) by the presence of combustible dusts, fibers or flyings. Service should only be conducted after power has been disconnected and the area is known to be free of ignitable concentrations of combustible substances (unclassified).

CUSTOMER KIT	PART NUMBER
Capacitor Replacement, 6.0Nm 72 RPM Motor, 60Hz	12-8064-10
Capacitor Replacement, 6.0Nm 72 RPM Motor, 50Hz	12-8064-20
Resistor Replacement, 6.0Nm 72 RPM Motor	12-8064-14
Motor (w/ SLM Replacement), 6.0Nm 72 RPM Motor	12-8064-01
SLM Replacement	12-8064-73
Control End Replacement (Option 3 model)	12-8064-65
Control End Replacement (Option 5 model)	12-8064-66
Control End Replacement (Option 7 model)	12-8064-67
Control End Retrofit (Option 3 model <i>manufactured prior to 01/01/10</i>)	12-8064-60
Control End Retrofit (Option 5 model <i>manufactured prior to 01/01/10</i>)	12-8064-61
Control End Retrofit (Option 7 model <i>manufactured prior to 01/01/10</i>)	12-8064-62
Fuse Replacement, Control End (Option 5 & 7 model)	12-8064-12
Feedback Potentiometer Replacement, Control End (Option 5 & 7 model)	12-8064-13
Gasket Replacement	20-3110-19

MAINTENANCE Troubleshooting

CONDITIONS	POSSIBLE CAUSES	CORRECTIONS
Actuator will not run in either direction with input signal applied.	<ul style="list-style-type: none"> a. Handswitch left in wrong position. b. No 120 Vac line supply. No lamps lit on control board. c. Fuse F-1 open. No lamps lit on control board. d. External auto/man switch in wrong position (Position-all). e. Torque on driven load shaft exceeds actuator torque rating. "S" LED on. f. Input signal below range or reversed. "L" LED on. g. Control board failure. 	<ul style="list-style-type: none"> a. Return Handswitch to auto position. b. Check fuses and switches in power panel. c. Check for possible shorts, then replace fuse. Use only Beck part no. 11-1370-10 for proper protection of triacs. d. Return switch to auto position. e. Check operation with Handswitch and remove obstruction. f. Input signal voltage between terminal 11 and 12 (+) must be between 1-5 Vdc. g. Replace control board.
Actuator runs only in one direction in auto and both directions with Handswitch in forward or reverse.	<ul style="list-style-type: none"> a. Zero adjustment incorrect. b. Loss of signal feature activated and actuator set to go to full forward or reverse position. "L" LED is on. c. Loss of feedback signal. d. Control board failure. 	<ul style="list-style-type: none"> a. Readjust Zero. See calibration, p.17. b. Check input signal against LOS trigger. c. Check feedback signals at terminals 13, 14 or 15. d. Replace control board.
Actuator runs in the wrong direction with input signal applied.	<ul style="list-style-type: none"> a. Input signal reversed. "L" LED on. b. Wiring to limit switches reversed. 	<ul style="list-style-type: none"> a. Check polarity of input signal. Terminal 12 is positive, 11 negative. b. Check limit switch connections. See Limit Switch adjustment, p.12.
Actuator shaft position oscillates.	<ul style="list-style-type: none"> a. Excessive noise on input signal. b. Control board failure. 	<ul style="list-style-type: none"> a. Check input signal. b. Replace control board.
Actuator does not stop at normal or desired limit of shaft travel.	<ul style="list-style-type: none"> a. Span or Zero adjusted incorrectly. b. Limit switches adjusted incorrectly. c. Loss of input signal. "L" LED on. d. Limit switch failure. 	<ul style="list-style-type: none"> a. Check control board calibration. See calibration procedure, p.18. b. Readjust limit switches. See limit switch adjustment, p.12. c. Restore input signal to actuator. d. Replace limit switch. Contact factory.
Loss of signal feature does not function.	<ul style="list-style-type: none"> a. Control board failure. 	<ul style="list-style-type: none"> a. Replace control board. See p.19.
Actuator activates to full retract or extend position and stays.	<ul style="list-style-type: none"> a. Handswitch left in forward or reverse position. b. Loss of input signal when LOS go to position is selected. "L" LED on. c. Loss of feedback signal. d. Control board failure. 	<ul style="list-style-type: none"> a. Return forward/reverse Handswitch (S1) to center STOP position. b. Restore input signal to actuator. c. Check feedback signal at terminals 13, 14 or 15. d. Replace control board.
Actuator movement erratic while driving from full extend to full retract and runs normally from full retract to full extend.	<ul style="list-style-type: none"> a. Feedback potentiometer dirty. Loss of wiper contact moves actuator in reverse direction. b. Feedback potentiometer open. 	<ul style="list-style-type: none"> a. Replace feedback potentiometer. b. Replace feedback potentiometer.
Actuator moves uncontrollably to position, then oscillates.	<ul style="list-style-type: none"> a. Feedback potentiometer open. 	<ul style="list-style-type: none"> a. Replace feedback potentiometer.
Pilot LED light out.	<ul style="list-style-type: none"> a. No power. b. Control section transformer failure. 	<ul style="list-style-type: none"> a. Check power sources. b. Replace control section transformer.
Feedback signal decreases when it should increase.	<ul style="list-style-type: none"> a. Plug P4 in wrong position on control board. 	<ul style="list-style-type: none"> a. Check feedback calibration procedure. See p.16.
Feedback signal does not reach maximum, but low end calibration is correct.	<ul style="list-style-type: none"> a. Output overload; load resistance is too low for voltage range or too high for current range. b. Low voltage. c. Feedback pot. not set correctly. d. Incorrect actuator feedback configuration 	<ul style="list-style-type: none"> a. Check load resistance against suggested feedback signal terminal hookup. b. Check line voltage at terminal board. c. Check feedback calibration procedure, p.16. d. Check feedback calibration procedure for correct R2 component on terminal board. See p.16.
Actuator does not reach desired travel limit.	<ul style="list-style-type: none"> a. Physical obstruction; e.g., valve jammed or load exceeds actuator rating. "S" LED on. 	<ul style="list-style-type: none"> a. Check operation with Handswitch and remove obstruction.

APPENDIX *Optional Water Ingress Protection*

Bellows water ingress protection kits are designed for applications where the G42 actuator is mounted outdoors with the front clevis oriented skyward (see example photo at right). The kit provides protection of the shaft seal and helps prevent water ingress over time.

The weight of each kit is less than one pound, so the effect on the overall weight of the actuator is negligible.



42-109 oriented skyward on an inlet guide vane blower

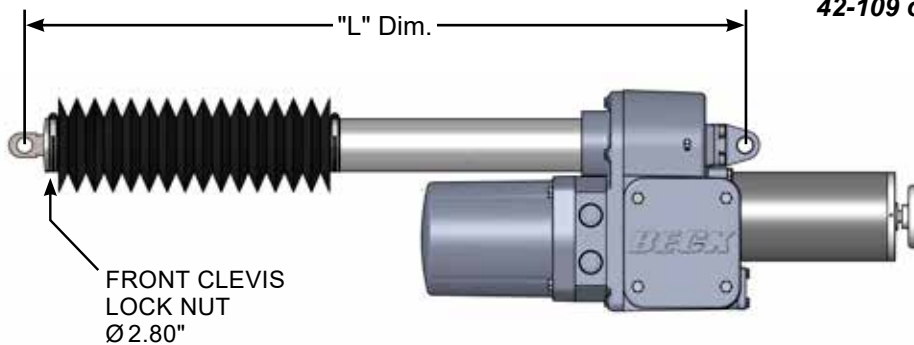

42-107 with a bellows water ingress protection kit installed

BELLOWS WATER INGRESS PROTECTION KITS

Kit No.	Clevis Hole Diameter (front/rear) (in) [mm]	Maximum Actuator Travel (in) [mm]	Minimum Actuator Travel (in) [mm]	Maximum Bellows Extension (in) [mm]	"L" Dim. Fully Retracted (in) [mm] ^{1,2}	"L" Dim. Fully Extended (in) [mm] ^{1,2}
20-3117-76	3/4 [19]	8 [203]	5 [127]	11 [279]	18 31/32 [482]	26 31/32 [685]
20-3117-77	3/4 [19]	12 [305]	7 [178]	22 1/2 [572]	22 31/32 [583]	34 31/32 [888]
20-3117-77	3/4 [19]	18 [457]	11 [279]	22 1/2 [572]	28 31/32 [736]	46 31/32 [1 193]
20-3117-78	1/2 [13]	8 [203]	5 [127]	11 [279]	18 31/32 [482]	26 31/32 [685]
20-3117-79	1/2 [13]	12 [305]	7 [178]	22 1/2 [572]	22 31/32 [583]	34 31/32 [888]
20-3117-79	1/2 [13]	18 [457]	11 [279]	22 1/2 [572]	28 31/32 [736]	46 31/32 [1 193]
20-3117-80	7/8 [22]	8 [203]	5 [127]	11 [279]	18 31/32 [482]	26 31/32 [685]
20-3117-81	7/8 [22]	12 [305]	7 [178]	22 1/2 [572]	22 31/32 [583]	34 31/32 [888]
20-3117-81	7/8 [22]	18 [457]	11 [279]	22 1/2 [572]	28 31/32 [736]	46 31/32 [1 193]

¹ When the bellows kit has been installed, the adjustment of the front clevis position is limited to +/- 1/4" from the values listed for dimension "L".

² In the event that the original "L" dimensions (prior to kit installation) are critical, modified rear clevis attachments are available to preserve the original mounting distance.

SERVICES

PRODUCT DEMONSTRATIONS

Each of Beck's Sales Engineers has access to a complete set of actuator models so that he can demonstrate virtually any of their features at your location. In order to arrange to see a Beck actuator in your plant or office, contact Beck's Sales Department.

SITE SURVEYS

Beck Sales Engineers are available to discuss your process control requirements. Often a visit to your location is the best way to gain a thorough understanding of your needs, in order to meet them most accurately and completely.

Mounting hardware, torque requirements, linkage, control signal information, and optional equipment can be analyzed most effectively at the worksite. Beck's analysis at the jobsite can help ensure that specifications are accurate, especially in the case of complex applications.

APPLICATION REVIEWS

By sharing your needs with a Beck Sales Engineer you can take advantage of the best application advice for the type of control you

need. This review will yield a better understanding of the versatility of Beck actuators for your installations, as well as complete details on options and accessories to make the process as effective as possible.

SPECIFICATION WRITING

Beck provides specification writing assistance in order to help you specify and order the right actuators for your applications. Beck Sales Engineers will work with you to make it easier for you to obtain the proper equipment and give you confidence that no details are overlooked.

HOW TO OBTAIN SERVICE

Factory repair of actuators or subassemblies is available for both normal and emergency service. To assure prompt processing, contact the factory to receive a Returned Material Authorization (RMA) number. If a repair estimation is desired, please send the name and phone number of your contact for service authorization. It is helpful to include a description of the work desired with the shipment or, in the event of a problem, the malfunction being experienced.

THREE YEAR LIMITED WARRANTY STATEMENT

Harold Beck & Sons, Inc. (Beck) warrants that our equipment shall conform to Beck's standard specifications. Beck warrants said equipment to be free from defects in materials and workmanship. This warranty applies to normal recommended use and service for three years from the date on which the equipment is shipped. Improper installation, misuse, improper maintenance, and normal wear and tear are not covered.

The Buyer must notify Beck of any warranty issues within 37 months of original shipment date and return the goods in question, at Buyer's expense, to Beck for evaluation. If the product fails to conform to the warranty, Beck's sole obligation and the Buyer's exclusive remedy will be: 1) the repair or replacement, without charge, at Beck's factory, of any defective equipment covered by this warranty, or 2) at Beck's option, a full refund of the purchase price. In no event will Beck's liability exceed the contract price for the goods claimed to be defective.

THIS WARRANTY IS EXPRESSLY IN LIEU OF ANY OTHER EXPRESS OR IMPLIED WARRANTY, INCLUDING IMPLIED WARRANTIES OF MERCHANTABILITY AND FITNESS FOR A PARTICULAR PURPOSE, AND ALL OTHER OBLIGATIONS OR LIABILITIES OF BECK. In no case shall Beck be liable for any special, incidental or consequential damages based upon breach of warranty, breach of contract, negligence, strict tort, or any other legal theory. Such damages include, but are not limited to, loss of profits, loss of revenue, loss of use of the equipment or any associated equipment, cost of capital, cost of any substitute equipment, facilities or service, downtime, the claims of third parties including customers and injury to property.

Buyer acknowledges its responsibilities under OSHA, related laws and regulations, and other safety laws, regulations, standards, practices or recommendations that are principally directed to the use of equipment in its operating environment. Buyer acknowledges that the conditions under which the equipment will be used, its use or combination with, or proximity to, other equipment, and other circumstances of the operation of such equipment are matters beyond Beck's control. **Buyer hereby agrees to indemnify Beck against all claims, damages, costs or liabilities (including but not limited to, attorney's fees and other legal expenses), whether on account of negligence or otherwise, except those claims based solely upon the negligence of Beck and those claims asserted by Beck's employees which arise out of or result from the operation or use of the equipment by Beck's employees.**

A 100% EMPLOYEE OWNED COMPANY

BECK

~ founded 1936 ~

SINCE 2021



HAROLD BECK & SONS, INC.

11 TERRY DRIVE • NEWTOWN, PENNSYLVANIA 18940 • USA

PHONE: 215-968-4600 • FAX: 215-860-6383 • E-MAIL: sales@haroldbeck.com

www.haroldbeck.com

Made in USA

